

Economic and Social Council

Inland Transport Committee

21 August 2023

Working Party on the Transport of Dangerous Goods

Original: English

Joint Meeting of Experts on the Regulations annexed to the European Agreement concerning the International Carriage of Dangerous Goods by Inland Waterways (ADN) (ADN Safety Committee)

Forty-second session

Geneva, 21-25 August 2023

Item 3(b) of the provisional agenda

Implementation of the European Agreement concerning the International Carriage of Dangerous Goods by Inland Waterways (ADN): special authorizations, derogations and equivalents

Request for a recommendation on the use of methanol as fuel for the propulsion of the tank vessel "Stolt Ijssel"

Transmitted by the Government of the Netherlands

Mts. Stolt IJssel - Methanol as Fuel

ADN Safety Committee
August 22nd, 2023

Mercurius Shipbuilding B.V.
Drs. Robert-Jan Zimmerman

SB Shipbuilding Solutions B.V.
Ing. Corné Borst



Content

1. Introduction
2. Choice for (green) Methanol
3. Stainless tanker Stolt IJssel
4. Design and Hazid study
5. Timeline
6. Questions

Mercurius Shipping Group

Inland shipping company active as:

- *Investor,*
- *Project developer / Shipbuilder,*
- *Ship operator, and*
- *Logistics service provider.*

Market leader in high end stainless steel chemical tankers

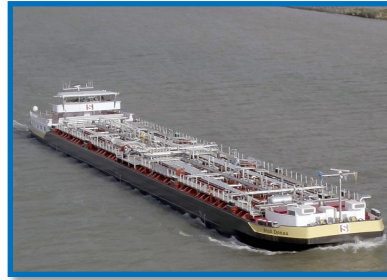



Mts. Stolt Ijsel (1st pilot)

Newbuilding stainless chemical tanker

- 110 x 14 m
- > 5.000 ton deadweight
- Diesel electric with engine room at foreship
- 3 x 603 kWe gensets Mitsubishi S6R - Stage V
- 3 x L-drive thrusters
- Sister vessels Oranje Nassau V, Oranje Nassau VI, Stolt Donau

Pilot:

- 1 genset (Stage V) will be converted to dual fuel (diesel/methanol).
- Methanol fuel tank on deck, in cargo zone (zone 0)



Methanol for Shipping – Stolt IJssel

Stolt-Nielsen 



INVESTNL

Why (green) Methanol?

Advantages:

- Relatively affordable climate-neutral fuel with significant reduction of harmful emissions;
- High level of acceptance in maritime shipping;
- No/hardly any restrictive limitations on range and load capacity;
- Relatively easy and safe to store and transport;
- IWT chemical tanker operations are familiar with methanol as cargo;
- LR has drafted regulations for use of methanol as fuel on IWT ships;
- Methanol intended to be accepted as fuel in ES-TRIN 2025;
- Methanol offers future opportunities as liquid carrier for hydrogen.

Disadvantages:

- Toxicity requires ADN training and sufficient safety provisions on board;
- About 2.3 x weight or 2.5 x storage volume compared to conventional diesel.

SB Shipbuilding Solutions

Ship design company

- *Ship design*
- *Project Management*
- *Consultancy*

Specialised in all types of inland waterway vessels.



Safety Philosophy

Methanol Hazards

- Flammable (11°C)
- Toxicity
(Special provisions Chapter 30 and (draft) Annex 8 ES-TRIN)

Safety Measures

- Tank location
- Engine room
- Engine (separate approval process)
- Crew training and bunkering procedures

Tank Location

- Storage tank abt. 37 m³ + bunkerstation in the cargo zone
- Tank safety measures equal to ADN requirements for methanol
 - 50 kPa design pressure
 - 40 kPa pressure alarm
 - Deck spray installation
 - Instruments T4, IIB, EX

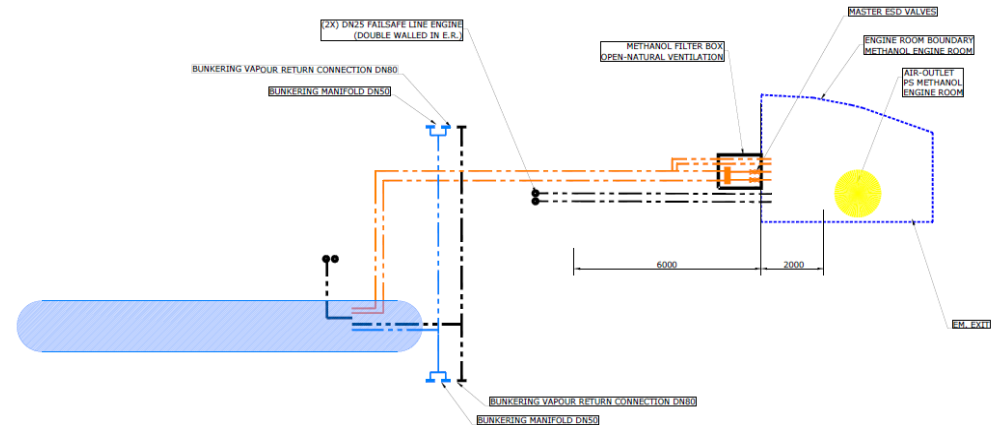
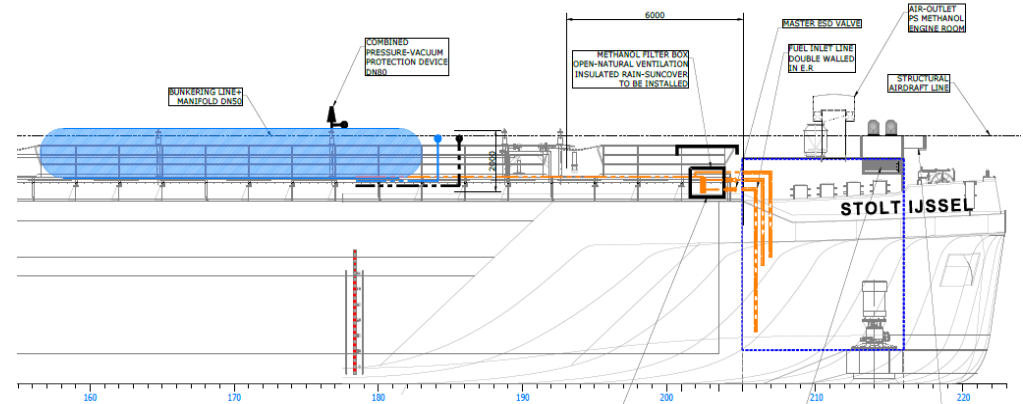

Engine Room

- Gasfree method
- Double walled piping
- Alarms:
 - Gas detection, >1% LEL or 500 PPM
 - Smoke / Heat detection
 - Bilge alarm
 - Ventilation failure
 - Fuel supply failure
- ESD Activation
 - Flame detection
 - Annulus space alarm
 - Gas detection 40% LEL

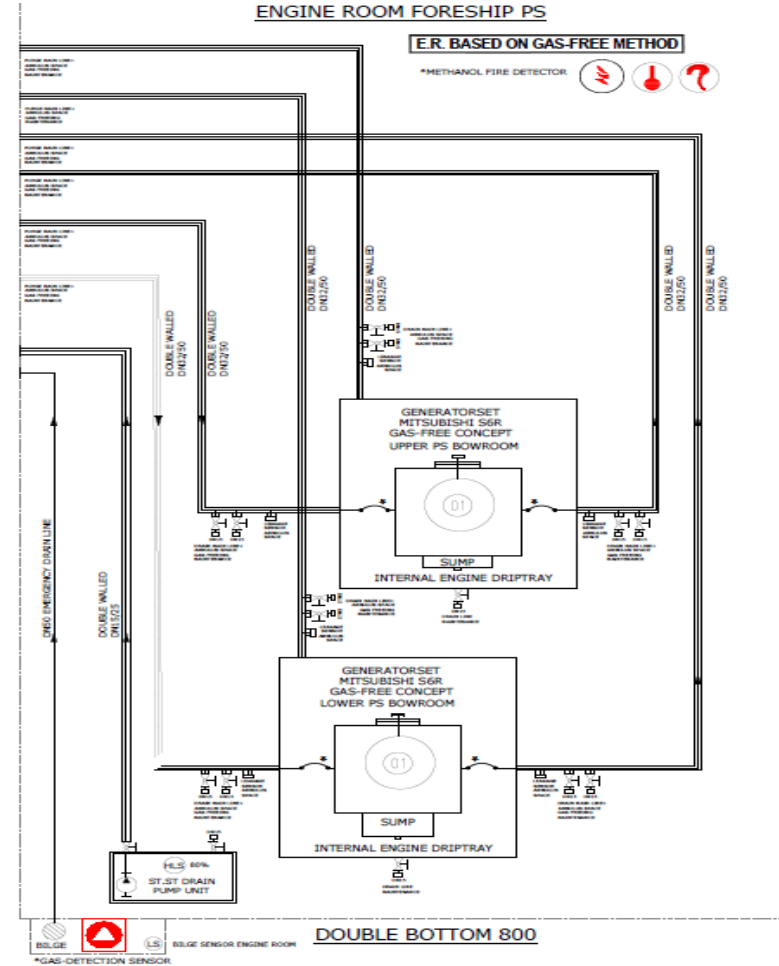

Engine

- Dual Fuel Type
- Gas Free Concept
- All methanol and high pressure diesel system parts double walled
- Leakage detection
- Purge facilities

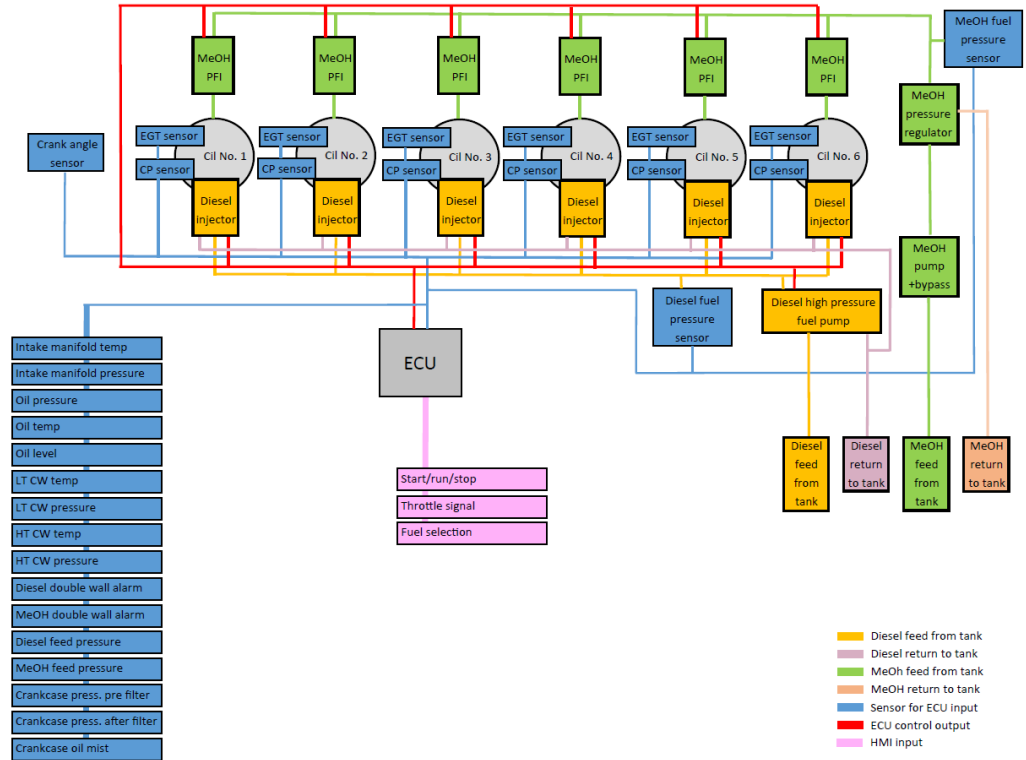

Bunkering procedure & Crew Training

- Truck to ship bunkering, included in HAZID
 - Phase 0 – Safe surroundings
 - Phase 1 – Preparation phase
 - Phase 2 – Bunkering
 - Phase 3 – Closing actions
- Crew training
 - The crew are familiar with the safe handling of chemicals and hazardous fluids and crew completed ADN courses.
 - There will be training provided on the safe operation of the system, this will be given to all crew on the ships.

Timeline

- Mts. Stolt IJssel is in service since April 7th. 2023 (*on 100% diesel*);
- Derogation of ES-TRIN received from CCR on January 16th. 2023;
- Delay in retro-fit kit for the dual fuel solution of the Mitsubishi genset
 - Originally planned for Q4/2022
 - Now anticipated for start pilot on board mid 2024;
- Pending recommendation by ADN Safety Committee.

Questions & Contact details

Mercurius Shipbuilding B.V.

Robert-Jan Zimmerman

+31(0)78-6259674

r.j.zimmerman@mercurius-group.nl

Langesteijn 102,
3342 LG Hendrik-Ido-Ambacht
The Netherlands

SB Shipbuilding Solutions

Corné Borst

+31(0)6-13625286

SB@shipbuilding-solutions.com

Noord 49a,
2931 SJ Krimpen aan de Lek
The Netherlands



Cargo List

STOLT IJSSEL

LR 9932347

ENI 02339855



Preface

The above ship has been approved for the transport of the products in this list, provided all the operational requirements regarding the transport have been complied with and the remarks as far as applicable to the cargoes to be transported have been respected.

This cargo list is based on the list of products in Part 3 Table C of the ADN regulations which came into force on the 1st of January 2023.

New products may only be included in this cargo list by virtue of a special permit and may only be transported in case this new product has been included in this list or in case a written confirmation of Lloyd's Register EMEA ("Europe, Middle East and Africa Region") is on board. A copy of the special permit should always be on board.

This cargo list is an addendum to the Certificate of Class, issued by Lloyd's Register EMEA for the above mentioned vessel. This cargo list is valid as long as the Certificate of Class is valid or in case a new cargo list has been issued by Lloyd's Register EMEA. In this case this cargo list will lose its validity and will be superseded by this new cargo list.

All pages are numbered.

Input data

This cargo list is based on the data below.

Ship

Name	STOLT IJSSEL
LR No.	9932347
ENI	02339855
Heeft een onderdekse pompkamer?	No
Temperature class	T4
Explosion group	IIB

Tank group 1

Materials	316 L Nr. 1.4401 CrNiMo, EN 1.4462
Tank vessel type	C
Cargo tank design	(2) Closed cargo tank
Cargo tank type	(2) Integral cargo tank

Equipment

Waterspray system	Yes
Inert gas installation	No
Quick valve to the shore	No
40 kPa pressure alarm	Yes
Pressure measurement on each tank	Yes
Spray prevention	Yes
Heated vapour return	Yes
Sampling device type	(1) Closed
Design specific gravity	1.60 ton/m ³
Opening pressure of high-velocity vent valve	50.0 kPa
Own heating system	Yes
Heating possibility without own heating system	No
Heating coils type	Filled with thermal oil
Tank refrigeration system	No

Ship specific remarks

UN	Description	Class	Classification code	Packing group	Dangers	%	Equipment	Remarks
1088	ACETAL	3	F1	II	3	97.0	PP, EX, A	
1090	ACETONE	3	F1	II	3	97.0	PP, EX, A	302
1092	ACROLEIN, STABILIZED	6.1	TF1	I	3, 6.1, unst., N1	95.0	PP, EP, EX, TOX, A	2, 3, 5, 23, 301, 303
1093	ACRYLONITRILE, STABILIZED	3	FT1	I	3, 6.1, unst., N2, CMR	95.0	PP, EP, EX, TOX, A	3, 5, 23, 301, 303
1098	ALLYL ALCOHOL	6.1	TF1	I	3, 6.1, N1	95.0	PP, EP, EX, TOX, A	
1105	PENTANOLS (n- PENTANOL)	3	F1	III	3	97.0	PP, EX, A	301
1106	AMYLAMINE (n-AMYLAMINE)	3	FC	II	3, 8	95.0	PP, EP, EX, A	
1107	AMYL CHLORIDES (1-CHLOROPENTANE)	3	F1	II	3	95.0	PP, EX, A	301, 304
1107	AMYL CHLORIDES (1-CHLORO-3-METHYLBUTANE)	3	F1	II	3	95.0	PP, EX, A	301, 303
1107	AMYL CHLORIDES (2-CHLORO-2-METHYLBUTANE)	3	F1	II	3	95.0	PP, EX, A	301, 303
1107	AMYL CHLORIDES (1-CHLORO-2,2-DIMETHYLPROPANE)	3	F1	II	3	95.0	PP, EX, A	301, 303
1114	BENZENE	3	F1	II	3, N3, CMR	95.0	PP, EP, EX, TOX, A	6: +10°C, 17, 23
1120	BUTANOLS (tert-BUTYL ALCOHOL)	3	F1	II	3	97.0	PP, EX, A	7, 17, 301
1120	BUTANOLS (sec-BUTYL ALCOHOL)	3	F1	III	3	97.0	PP, EX, A	301
1120	BUTANOLS (n- BUTYL ALCOHOL)	3	F1	III	3	97.0	PP, EX, A	301
1123	BUTYL ACETATES (sec-BUTYL ACETATE)	3	F1	II	3	97.0	PP, EX, A	
1123	BUTYL ACETATES (n-BUTYL ACETATE)	3	F1	III	3, N3	97.0	PP, EX, A	
1125	n-BUTYLAMINE	3	FC	II	3, 8, N3	95.0	PP, EP, EX, A	23, 301
1127	CHLOROBUTANES (1-CHLOROBUTANE)	3	F1	II	3	95.0	PP, EX, A	23, 301, 303
1127	CHLOROBUTANES (2-CHLOROBUTANE)	3	F1	II	3	95.0	PP, EX, A	23, 301, 303
1127	CHLOROBUTANES (1-CHLORO-2-METHYLPROPANE)	3	F1	II	3	95.0	PP, EX, A	23, 301, 304
1127	CHLOROBUTANES (2-CHLORO-2-METHYLPROPANE)	3	F1	II	3	95.0	PP, EX, A	23, 301, 303
1129	BUTYRALDEHYDE (n-BUTYRALDEHYDE)	3	F1	II	3, N3	95.0	PP, EX, A	15, 23, 301
1134	CHLOROBENZENE (phenyl chloride)	3	F1	III	3, N2, S	95.0	PP, EX, A	301, 303
1135	ETHYLENE CHLOROXYDRIN (2-CHLOROETHANOL)	6.1	TF1	I	3, 6.1, N2	95.0	PP, EP, EX, TOX, A	301, 303
1143	CROTONALDEHYDE or CROTONALDEHYDE, STABILIZED	6.1	TF1	I	3, 6.1, unst., N1	95.0	PP, EP, EX, TOX, A	3, 5, 15, 301, 303

UN	Description	Class	Classification code	Packing group	Dangers	%	Equipment	Remarks
1145	CYCLOHEXANE	3	F1	II	3, N1	95.0	PP, EX, A	6: +11°C, 17
1146	CYCLOPENTANE	3	F1	II	3, N2	97.0	PP, EX, A	
1148	DIACETONE ALCOHOL	3	F1	III	3	97.0	EX, A	302, 304
1150	1,2-DICHLOROETHYLENE (cis-1,2-DICHLOROETHYLENE)	3	F1	II	3, N2	95.0	PP, EX, A	23, 301, 303
1150	1,2-DICHLOROETHYLENE (trans-1,2-DICHLOROETHYLENE)	3	F1	II	3, N2	95.0	PP, EX, A	23, 301, 303
1153	ETHYLENE GLYCOL DIETHYL ETHER	3	F1	III	3	97.0	PP, EX, A	
1154	DIETHYLAMINE	3	FC	II	3, 8, N3	95.0	PP, EP, EX, A	23, 301
1157	DIISOBUTYL KETONE	3	F1	III	3, N3, F	97.0	PP, EX, A	
1159	DIISOPROPYL ETHER	3	F1	II	3, N2	95.0	PP, EX, A	
1160	DIMETHYLAMINE AQUEOUS SOLUTION	3	FC	II	3, 8, N3	95.0	PP, EP, EX, A	23, 301
1163	DIMETHYLHYDRAZINE, UNSYMMETRICAL	6.1	TFC	I	3, 6.1, 8, N2, CMR	95.0	PP, EP, EX, TOX, A	23
1165	DIOXANE	3	F1	II	3	97.0	PP, EX, A	6: +14°C, 17, 301, 303
1170	ETHANOL (ETHYL ALCOHOL) or ETHANOL SOLUTION (ETHYL ALCOHOL SOLUTION), aqueous solution with more than 70% alcohol by volume	3	F1	II	3	97.0	PP, EX, A	301
1170	ETHANOL SOLUTION (ETHYL ALCOHOL SOLUTION), aqueous solution with more than 24% and not more than 70% alcohol by volume	3	F1	III	3	97.0	PP, EX, A	301
1171	ETHYLENE GLYCOL MONOETHYL ETHER	3	F1	III	3, CMR	97.0	PP, EP, EX, TOX, A	
1172	ETHYLENE GLYCOL MONOETHYL ETHER ACETATE	3	F1	III	3, N3, CMR	97.0	PP, EP, EX, TOX, A	
1173	ETHYL ACETATE	3	F1	II	3	97.0	PP, EX, A	
1175	ETHYLBENZENE	3	F1	II	3, N3	97.0	PP, EX, A	
1177	2-ETHYLBUTYL ACETATE	3	F1	III	3	97.0	PP, EX, A	
1179	ETHYL BUTYLETHER (ETHYL tert-BUTYLETHER)	3	F1	II	3, N3	97.0	PP, EX, A	
1184	ETHYLENE DICHLORIDE (1,2-dichloroethane)	3	FT1	II	3, 6.1, CMR	95.0	PP, EP, EX, TOX, A	301, 303
1188	ETHYLENE GLYCOL MONOMETHYL ETHER	3	F1	III	3, CMR	97.0	PP, EP, EX, TOX, A	
1191	OCTYL ALDEHYDES (2-ETHYLCAPRONALDEHYDE)	3	F1	III	3, F	95.0	PP, EX, A	



UN	Description	Class	Classification code	Packing group	Dangers	%	Equipment	Remarks
1191	OCTYL ALDEHYDES (n-OCTALDEHYDE)	3	F1	III	3, N3, F	97.0	PP, EX, A	304
1193	ETHYL METHYL KETONE (METHYL ETHYL KETONE)	3	F1	II	3	97.0	PP, EX, A	
1198	FORMALDEHYDE SOLUTION, FLAMMABLE	3	FC	III	3, 8, N3	97.0	PP, EP, EX, A	34, 301, 303
1199	FURALDEHYDES (a-FURALDEHYDE) or FURFURALDEHYDES (a-FURFURYLALDEHYDE)	6.1	TF1	II	3, 6.1	95.0	PP, EP, EX, TOX, A	15, 301
1202	GAS OIL or DIESEL FUEL or HEATING OIL (LIGHT) (flash-point not more than 60 °C)	3	F1	III	3 + (N1, N2, N3, CMR, F or S)	97.0	PP	22
1202	GAS OIL complying with standard EN 590:2013 + A1:2017 or DIESEL FUEL or HEATING OIL, LIGHT with flash-point as specified in EN 590:2013 + A1:2017	3	F1	III	3, N2, F	97.0	PP	22
1202	GAS OIL or DIESEL FUEL or HEATING OIL, LIGHT (flash-point more than 60°C but not more than 100°C)	3	F1	III	3 + (N1, N2, N3, CMR, F or S)	97.0	PP	22
1203	MOTOR SPIRIT or GASOLINE or PETROL	3	F1	II	3, N2, CMR, F	97.0	PP, EP, EX, TOX, A	14
1203	MOTOR SPIRIT or GASOLINE or PETROL WITH MORE THAN 10% BENZENE 60°C < BOILING POINT =< 85°C	3	F1	II	3, N2, CMR, F	95.0	PP, EP, EX, TOX, A	23
1203	MOTOR SPIRIT or GASOLINE or PETROL WITH MORE THAN 10% BENZENE 85°C < boiling point =< 115°C	3	F1	II	3, N2, CMR, F	95.0	PP, EP, EX, TOX, A	
1203	MOTOR SPIRIT or GASOLINE or PETROL WITH MORE THAN 10% BENZENE boiling point > 115°C	3	F1	II	3, N2, CMR, F	95.0	PP, EP, EX, TOX, A	
1203	MOTOR SPIRIT or GASOLINE or PETROL WITH MORE THAN 10% BENZENE (Flash point < 23°C with 60°C < BOILING POINT =< 85°C)	3	F1	II	3, N2, CMR, F	95.0	PP, EP, EX, TOX, A	22, 23
1203	MOTOR SPIRIT or GASOLINE or PETROL WITH MORE THAN 10% BENZENE (Flash point < 23°C with 85°C < BOILING POINT =< 115°C)	3	F1	II	3, N2, CMR, F	95.0	PP, EP, EX, TOX, A	22
1203	MOTOR SPIRIT or GASOLINE or PETROL WITH MORE THAN 10% BENZENE (Flash point < 23°C with BOILING POINT > 115°C)	3	F1	II	3, N2, CMR, F	95.0	PP, EP, EX, TOX, A	22
1206	HEPTANES	3	F1	II	3, N1	95.0	PP, EX, A	
1208	HEXANES	3	F1	II	3, N2	97.0	PP, EX, A	
1208	HEXANES	3	F1	II	3, N2	97.0	PP, EX, A	
1212	ISOBUTANOL (isobutyl alcohol)	3	F1	III	3	97.0	PP, EX, A	301



UN	Description	Class	Classification code	Packing group	Dangers	%	Equipment	Remarks
1213	ISOBUTYL ACETATE	3	F1	II	3, N3	97.0	PP, EX, A	
1214	ISOBUTYLAMINE	3	FC	II	3, 8, N3	95.0	PP, EP, EX, A	23
1216	ISOOCTENES	3	F1	II	3, N2	97.0	PP, EX, A	
1219	ISOPROPANOL (isopropyl alcohol)	3	F1	II	3	97.0	PP, EX, A	
1220	ISOPROPYL ACETATE	3	F1	II	3	97.0	PP, EX, A	
1223	KEROSENE	3	F1	III	3, N2, F	97.0	PP, EX, A	14
1224	KETONES, LIQUID, N.O.S. (Flash point < 23°C with 110 kPa<=vP50<150 kPa)	3	F1	II	3 + (N1, N2, N3, CMR, F or S)	97.0	PP, EP, EX, TOX, A	14, 22, 27, 301
1224	KETONES, LIQUID, N.O.S. (Flash point < 23°C with vP50<110 kPa)	3	F1	II	3 + (N1, N2, N3, CMR, F or S)	97.0	PP, EP, EX, TOX, A	14, 22, 27, 301
1224	KETONES, LIQUID, N.O.S. Flash point >= 23°C but <= 60°C	3	F1	III	3 + (N1, N2, N3, CMR, F or S)	97.0	PP, EP, EX, TOX, A	14, 22, 27, 301
1224	KETONES, LIQUID, N.O.S. (Flash point < 23°C with 110 kPa<=vP50<175 kPa)	3	F1	II	3 + (N1, N2, N3, CMR, F or S)	97.0	PP, EP, EX, TOX, A	14, 27, 301
1229	MESITYL OXIDE	3	F1	III	3	97.0	PP, EX, A	
1230	METHANOL	3	FT1	II	3, 6.1	95.0	PP, EP, EX, TOX, A	23
1231	METHYL ACETATE	3	F1	II	3	97.0	PP, EX, A	
1235	METHYLAMINE, AQUEOUS SOLUTION	3	FC	II	3, 8, N3	95.0	PP, EP, EX, A	301
1245	METHYL ISOBUTYL KETONE	3	F1	II	3	97.0	PP, EX, A	
1247	METHYL METHACRYLATE MONOMER, STABILIZED	3	F1	II	3, unst., N3	95.0	PP, EX, A	3, 5, 16, 301, 303
1262	OCTANES	3	F1	II	3, N1	95.0	PP, EX, A	
1264	PARALDEHYDE	3	F1	III	3	97.0	PP, EX, A	6: +16°C, 17
1265	PENTANES, liquid (n-PENTANE)	3	F1	II	3, N2	97.0	PP, EX, A	301
1265	PENTANES, liquid (Flash point < 23°C with 150 kPa<=vP50<175 kPa)	3	F1	I	3, N2	97.0	PP, EX, A	14, 22, 302, 304
1265	PENTANES, liquid (Flash point < 23°C with 150 kPa<=vP50<175 kPa)	3	F1	II	3, N2	97.0	PP, EX, A	14, 22, 302, 304
1265	PENTANES, liquid (Flash point < 23°C with 110 kPa<=vP50<150 kPa)	3	F1	I	3, N2	97.0	PP, EX, A	14, 22, 302, 304
1265	PENTANES, liquid (Flash point < 23°C with 110 kPa<=vP50<150 kPa)	3	F1	II	3, N2	97.0	PP, EX, A	14, 22, 302, 304
1265	PENTANES, liquid (Flash point < 23°C with 110 kPa<=vP50<150 kPa)	3	F1	I	3, N2	97.0	PP, EX, A	14, 22, 302, 304



UN	Description	Class	Classification code	Packing group	Dangers	%	Equipment	Remarks
1265	PENTANES, liquid (Flash point < 23°C with 110 kPa<=vP50<150 kPa)	3	F1	II	3, N2	97.0	PP, EX, A	14, 22, 302, 304
1265	PENTANES, liquid (Flash point < 23°C with vP50<110 kPa)	3	F1	I	3, N2	97.0	PP, EX, A	14, 22, 302, 304
1265	PENTANES, liquid (Flash point < 23°C with vP50<110 kPa)	3	F1	II	3, N2	97.0	PP, EX, A	14, 22, 302, 304
1267	PETROLEUM CRUDE OIL WITH MORE THAN 10% BENZENE 60 °C < INITIAL BOILING POINT =< 85 °C	3	F1	II	3, CMR, F + (N1, N2, N3)	95.0	PP, EP, EX, TOX, A	22, 23, 38, 301
1267	PETROLEUM CRUDE OIL WITH MORE THAN 10% BENZENE 85 °C < INITIAL BOILING POINT =< 115 °C	3	F1	II	3, CMR, F + (N1, N2, N3)	95.0	PP, EP, EX, TOX, A	22, 301
1267	PETROLEUM CRUDE OIL WITH MORE THAN 10% BENZENE INITIAL BOILING POINT > 115 °C	3	F1	II	3, CMR, F + (N1, N2, N3)	95.0	PP, EP, EX, TOX, A	22, 301
1267	PETROLEUM CRUDE OIL WITH MORE THAN 10% BENZENE 60 °C < INITIAL BOILING POINT =< 85 °C	3	F1	III	3, CMR, F + (N1, N2, N3)	95.0	PP, EP, EX, TOX, A	22, 23, 38, 301
1267	PETROLEUM CRUDE OIL WITH MORE THAN 10% BENZENE 85 °C < INITIAL BOILING POINT =< 115 °C	3	F1	III	3, CMR, F + (N1, N2, N3)	95.0	PP, EP, EX, TOX, A	22, 301
1267	PETROLEUM CRUDE OIL (Flash point < 23°C with 110 kPa<=vP50<175 kPa)	3	F1	I	3 + (N1, N2, N3, CMR, F)	97.0	PP, EP, EX, TOX, A	14, 22, 301
1267	PETROLEUM CRUDE OIL (Flash point < 23°C with 110 kPa<=vP50<175 kPa)	3	F1	II	3 + (N1, N2, N3, CMR, F)	97.0	PP, EP, EX, TOX, A	14, 22, 301
1267	PETROLEUM CRUDE OIL (Flash point < 23°C with 110 kPa<=vP50< 150 kPa)	3	F1	I	3 + (N1, N2, N3, CMR, F)	97.0	PP, EP, EX, TOX, A	14, 22, 301
1267	PETROLEUM CRUDE OIL (Flash point < 23°C with 110 kPa<=vP50< 150 kPa)	3	F1	II	3 + (N1, N2, N3, CMR, F)	97.0	PP, EP, EX, TOX, A	14, 22, 301
1267	PETROLEUM CRUDE OIL (Flash point < 23°C with vP50<110 kPa)	3	F1	I	3 + (N1, N2, N3, CMR, F)	97.0	PP, EP, EX, TOX, A	14, 22, 301
1267	PETROLEUM CRUDE OIL (Flash point < 23°C with vP50<110 kPa)	3	F1	II	3 + (N1, N2, N3, CMR, F)	97.0	PP, EP, EX, TOX, A	14, 22, 301
1267	PETROLEUM CRUDE OIL (Flash point >= 23°C but <= 60°C)	3	F1	III	3 + (N1, N2, N3, CMR, F)	97.0	PP, EP, EX, TOX, A	14, 22, 301
1267	PETROLEUM CRUDE OIL WITH MORE THAN 10% BENZENE INITIAL BOILING POINT > 115 °C	3	F1	III	3, CMR, F + (N1, N2, N3)	95.0	PP, EP, EX, TOX, A	22, 301
1267	PETROLEUM CRUDE OIL WITH MORE THAN 10% BENZENE (Flash point < 23°C with 60 °C < BOILING POINT =< 85 °C)	3	F1	I	3, CMR, F + (N1, N2, N3)	95.0	PP, EP, EX, TOX, A	22, 23, 301

UN	Description	Class	Classification code	Packing group	Dangers	%	Equipment	Remarks
1267	PETROLEUM CRUDE OIL WITH MORE THAN 10% BENZENE (Flash point < 23°C with 60 °C < BOILING POINT =< 85 °C)	3	F1	II	3, N1, N2, N3, CMR, F	95.0	PP, EP, EX, TOX, A	22, 23, 301
1267	PETROLEUM CRUDE OIL WITH MORE THAN 10% BENZENE (60 °C < BOILING POINT =< 85 °C)	3	F1	III	3, CMR, F + (N1, N2, N3)	95.0	PP, EP, EX, TOX, A	22, 23, 301
1267	PETROLEUM CRUDE OIL WITH MORE THAN 10% BENZENE (Flash point < 23°C with 85 °C < BOILING POINT =< 115 °C)	3	F1	I	3, CMR, F + (N1, N2, N3)	95.0	PP, EP, EX, TOX, A	22, 301
1267	PETROLEUM CRUDE OIL WITH MORE THAN 10% BENZENE (Flash point < 23°C with 85 °C < BOILING POINT =< 115 °C)	3	F1	II	3, CMR, F + (N1, N2, N3)	95.0	PP, EP, EX, TOX, A	22, 301
1267	PETROLEUM CRUDE OIL WITH MORE THAN 10% BENZENE (85 °C < BOILING POINT =< 115 °C)	3	F1	III	3, CMR, F + (N1, N2, N3)	95.0	PP, EP, EX, TOX, A	22, 301
1267	PETROLEUM CRUDE OIL WITH MORE THAN 10% BENZENE (Flash point < 23°C with BOILING POINT > 115 °C)	3	F1	I	3, CMR, F + (N1, N2, N3)	95.0	PP, EP, EX, TOX, A	22, 301
1267	PETROLEUM CRUDE OIL WITH MORE THAN 10% BENZENE (Flash point < 23°C with BOILING POINT > 115 °C)	3	F1	II	3, CMR, F + (N1, N2, N3)	95.0	PP, EP, EX, TOX, A	22, 301
1267	PETROLEUM CRUDE OIL WITH MORE THAN 10% BENZENE (BOILING POINT > 115 °C)	3	F1	III	3, CMR, F + (N1, N2, N3)	95.0	PP, EP, EX, TOX, A	22, 301
1267	PETROLEUM CRUDE OIL WITH MORE THAN 10% BENZENE (According ADN 3.2.3.3 – Scheme A – Criteria for cargo tank equipment in vessels of Type C)	3	F1	I	3, CMR, F + (N1, N2, N3)	95.0	PP, EP, EX, TOX, A	22, 23, 98, 301
1267	PETROLEUM CRUDE OIL WITH MORE THAN 10% BENZENE (According ADN 3.2.3.3 – Scheme A – Criteria for cargo tank equipment in vessels of Type C)	3	F1	II	3, CMR, F + (N1, N2, N3)	95.0	PP, EP, EX, TOX, A	22, 23, 98, 301
1268	PETROLEUM DISTILLATES, N.O.S. or PETROLEUM PRODUCTS, N.O.S. WITH MORE THAN 10% BENZENE INITIAL BOILING POINT > 115 °C	3	F1	II	3, N1, N2, N3, CMR, F	95.0	PP, EP, EX, TOX, A	302
1268	PETROLEUM DISTILLATES, N.O.S. or PETROLEUM PRODUCTS, N.O.S. (NAPHTHA) 110 kPa < vp50 =< 175 kPa	3	F1	II	3, N2, CMR, F	97.0	PP, EP, EX, TOX, A	14, 302
1268	PETROLEUM DISTILLATES, N.O.S. or PETROLEUM PRODUCTS, N.O.S. (NAPHTHA) 110 kPa < vp50 =< 150 kPa	3	F1	II	3, N2, CMR, F	97.0	PP, EP, EX, TOX, A	14, 302
1268	PETROLEUM DISTILLATES, N.O.S. or PETROLEUM PRODUCTS, N.O.S. (NAPHTHA) vp50 =< 110 kPa	3	F1	II	3, N2, CMR, F	97.0	PP, EP, EX, TOX, A	14, 302

UN	Description	Class	Classification code	Packing group	Dangers	%	Equipment	Remarks
1268	PETROLEUM DISTILLATES, N.O.S. or PETROLEUM PRODUCTS, N.O.S. (BENZENE HEART CUT) vp50 =< 110 kPa	3	F1	II	3, N2, CMR, F	97.0	PP, EP, EX, TOX, A	14, 302
1268	PETROLEUM DISTILLATES, N.O.S. or PETROLEUM PRODUCTS, N.O.S. WITH MORE THAN 10% BENZENE 60 °C < INITIAL BOILING POINT =< 85 °C	3	F1	II	3, N1, N2, N3, CMR, F	95.0	PP, EP, EX, TOX, A	23, 38, 302
1268	PETROLEUM DISTILLATES, N.O.S. or PETROLEUM PRODUCTS, N.O.S. WITH MORE THAN 10% BENZENE 85 °C < INITIAL BOILING POINT =< 115 °C	3	F1	II	3, N1, N2, N3, CMR, F	95.0	PP, EP, EX, TOX, A	302
1268	PETROLEUM DISTILLATES, N.O.S. or PETROLEUM PRODUCTS, N.O.S (Flash point < 23°C with 110 kPa<=vP50<175 kPa)	3	F1	I	3 + (N1, N2, N3, CMR, F)	97.0	PP, EP, EX, TOX, A	14, 22, 301
1268	PETROLEUM DISTILLATES, N.O.S. or PETROLEUM PRODUCTS, N.O.S (Flash point < 23°C with 110 kPa<=vP50<175 kPa)	3	F1	II	3 + (N1, N2, N3, CMR, F)	97.0	PP, EP, EX, TOX, A	14, 22, 301
1268	PETROLEUM DISTILLATES, N.O.S. or PETROLEUM PRODUCTS, N.O.S (Flash point < 23°C with 110 kPa<=vP50<150 kPa)	3	F1	II	3 + (N1, N2, N3, CMR, F)	97.0	PP, EP, EX, TOX, A	14, 22, 301
1268	PETROLEUM DISTILLATES, N.O.S. or PETROLEUM PRODUCTS, N.O.S (Flash point < 23°C with 110 kPa<=vP50<150 kPa)	3	F1	I	3 + (N1, N2, N3, CMR, F)	97.0	PP, EP, EX, TOX, A	14, 22, 301
1268	PETROLEUM DISTILLATES, N.O.S. or PETROLEUM PRODUCTS, N.O.S (Flash point < 23°C with vP50<110 kPa)	3	F1	I	3 + (N1, N2, N3, CMR, F)	97.0	PP, EP, EX, TOX, A	14, 22, 301
1268	PETROLEUM DISTILLATES, N.O.S. or PETROLEUM PRODUCTS, N.O.S (Flash point < 23°C with vP50<110 kPa)	3	F1	II	3 + (N1, N2, N3, CMR, F)	97.0	PP, EP, EX, TOX, A	14, 22, 301
1268	PETROLEUM DISTILLATES, N.O.S. or PETROLEUM PRODUCTS, N.O.S (Flash point >= 23°C but <= 60 °C)	3	F1	III	3 + (N1, N2, N3, CMR, F)	97.0	PP, EP, EX, TOX, A	14, 22, 301
1268	PETROLEUM DISTILLATES, N.O.S. or PETROLEUM PRODUCTS, N.O.S. WITH MORE THAN 10% BENZENE (Flash point < 23°C with 60 °C < BOILING POINT =< 85 °C)	3	F1	I	3, CMR, F + (N1, N2, N3)	95.0	PP, EP, EX, TOX, A	22, 23, 302
1268	PETROLEUM DISTILLATES, N.O.S. or PETROLEUM PRODUCTS, N.O.S. WITH MORE THAN 10% BENZENE (Flash point < 23°C with 60 °C < BOILING POINT =< 85 °C)	3	F1	II	3, CMR, F + (N1, N2, N3)	95.0	PP, EP, EX, TOX, A	22, 23, 302

UN	Description	Class	Classification code	Packing group	Dangers	%	Equipment	Remarks
1268	PETROLEUM DISTILLATES, N.O.S. or PETROLEUM PRODUCTS, N.O.S. WITH MORE THAN 10% BENZENE (60 °C < BOILING POINT =< 85 °C)	3	F1	III	3, CMR, F + (N1, N2, N3)	95.0	PP, EP, EX, TOX, A	22, 23, 302
1268	PETROLEUM DISTILLATES, N.O.S. or PETROLEUM PRODUCTS, N.O.S. WITH MORE THAN 10% BENZENE (85 °C < BOILING POINT =< 115 °C)	3	F1	III	3, CMR, F + (N1, N2, N3)	95.0	PP, EP, EX, TOX, A	22, 302
1268	PETROLEUM DISTILLATES, N.O.S. or PETROLEUM PRODUCTS, N.O.S. WITH MORE THAN 10% BENZENE (Flash point < 23°C with 85 °C < BOILING POINT =< 115 °C)	3	F1	II	3, CMR, F + (N1, N2, N3)	95.0	PP, EP, EX, TOX, A	22, 302
1268	PETROLEUM DISTILLATES, N.O.S. or PETROLEUM PRODUCTS, N.O.S. WITH MORE THAN 10% BENZENE (Flash point < 23°C with 85 °C < BOILING POINT =< 115 °C)	3	F1	I	3, CMR, F + (N1, N2, N3)	95.0	PP, EP, EX, TOX, A	22, 302
1268	PETROLEUM DISTILLATES, N.O.S. or PETROLEUM PRODUCTS, N.O.S. WITH MORE THAN 10% BENZENE (Flash point < 23°C with BOILING POINT > 115 °C)	3	F1	I	3, CMR, F + (N1, N2, N3)	95.0	PP, EP, EX, TOX, A	22, 302
1268	PETROLEUM DISTILLATES, N.O.S. or PETROLEUM PRODUCTS, N.O.S. WITH MORE THAN 10% BENZENE (Flash point < 23°C with BOILING POINT > 115 °C)	3	F1	II	3, CMR, F + (N1, N2, N3)	95.0	PP, EP, EX, TOX	22, 302
1268	PETROLEUM DISTILLATES, N.O.S. or PETROLEUM PRODUCTS, N.O.S. WITH MORE THAN 10% BENZENE (BOILING POINT > 115 °C)	3	F1	III	3, CMR, F + (N1, N2, N3)	95.0	PP, EP, EX, TOX, A	22, 302
1268	PETROLEUM DISTILLATES, N.O.S. or PETROLEUM PRODUCTS, N.O.S. WITH MORE THAN 10% BENZENE (According ADN 3.2.3.3 – Scheme A – Criteria for cargo tank equipment in vessels of Type C)	3	F1	I	3, CMR, F + (N1, N2, N3)	95.0	PP, EP, EX, TOX, A	22, 23, 98, 302
1268	PETROLEUM DISTILLATES, N.O.S. or PETROLEUM PRODUCTS, N.O.S. WITH MORE THAN 10% BENZENE (According ADN 3.2.3.3 – Scheme A – Criteria for cargo tank equipment in vessels of Type C)	3	F1	II	3, CMR, F + (N1, N2, N3)	95.0	PP, EP, EX, TOX, A	22, 23, 98, 302
1274	n-PROPANOL (propyl alcohol, normal)	3	F1	II	3	97.0	PP, EX, A	
1274	n-PROPANOL (propyl alcohol, normal)	3	F1	III	3	97.0	PP, EX, A	
1275	PROPIIONALDEHYDE	3	F1	II	3, N3	95.0	PP, EX, A	15, 23, 301
1276	n-PROPYL ACETATE	3	F1	II	3, N3	97.0	PP, EX, A	
1277	PROPYLAMINE (1-aminopropane)	3	FC	II	3, 8	95.0	PP, EP, EX, A	23, 301

UN	Description	Class	Classification code	Packing group	Dangers	%	Equipment	Remarks
1278	1-CHLOROPROPANE (propyl chloride)	3	F1	II	3	95.0	PP, EX, A	23, 301, 303
1279	1,2-DICHLOROPROPANE or PROPYL DICHLORIDE	3	F1	II	3, N2	95.0	PP, EX, A	301, 303
1282	PYRIDINE	3	F1	II	3, N3	97.0	PP, EX, A	
1288	SHALE OIL	3	F1	II	3, N3, CMR	97.0	PP, EP, EX, TOX, A	14, 23, 302, 304
1288	SHALE OIL	3	F1	III	3, N3, CMR	97.0	PP, EP, EX, TOX, A	14, 23, 302, 304
1289	SODIUM METHYLATE SOLUTION in alcohol	3	FC	III	3, 8	97.0	PP, EP, EX, A	34, 301
1294	TOLUENE	3	F1	II	3, N3	97.0	PP, EX, A	
1296	TRIETHYLAMINE	3	FC	II	3, 8, N3	95.0	PP, EP, EX, A	301
1300	TURPENTINE SUBSTITUTE	3	F1	III	3, N2, F	97.0	PP, EX, A	
1301	VINYL ACETATE, STABILIZED	3	F1	II	3, unst., N3	97.0	PP, EX, A	3, 5, 16
1307	XYLENES (o-XYLENE)	3	F1	III	3, N2	97.0	PP, EX, A	
1307	XYLENES (m-XYLENE)	3	F1	III	3, N2	97.0	PP, EX, A	
1307	XYLENES (p-XYLENE)	3	F1	III	3, N2	97.0	PP, EX, A	6: +17°C, 17
1307	XYLENES (mixture with melting point =< 0°C)	3	F1	II	3, N2	97.0	PP, EX, A	
1307	XYLENES (mixture with melting point =< 0°C)	3	F1	III	3, N2	97.0	PP, EX, A	
1307	XYLENES (mixture with melting point > 0°C < 13°C)	3	F1	III	3, N2	97.0	PP, EX, A	6: +17°C, 17
1541	ACETONE CYANOHYDRIN, STABILIZED	6.1	T1	I	6.1, unst., N1	95.0	PP, EP, TOX, A	3, 301, 303
1545	ALLYL ISOTHIOCYANATE, STABILIZED	6.1	TF1	II	3, 6.1, unst.	95.0	PP, EP, EX, TOX, A	2, 3, 301, 303
1547	ANILINE	6.1	T1	II	6.1, N1	95.0	PP, EP, TOX, A	
1591	o-DICHLOROBENZENE	6.1	T1	III	6.1, N1, S	95.0	PP, EP, TOX, A	301, 303
1593	DICHLOROMETHANE (methyl chloride)	6.1	T1	III	6.1	95.0	PP, EP, TOX, A	23, 301, 303
1594	DIETHYLSULPHATE	6.1	T1	II	6.1, N2, CMR	95.0	PP, EP, TOX, A	301
1595	DIMETHYL SULPHATE	6.1	TC1	I	6.1, 8, N3, CMR	95.0	PP, EP, TOX, A	301
1604	ETHYLENEDIAMINE	8	CF1	II	3, 8, N3	97.0	PP, EP, EX, A	6: +12°C, 17, 34, 301

UN	Description	Class	Classification code	Packing group	Dangers	%	Equipment	Remarks
1605	ETHYLENE DIBROMIDE	6.1	T1	I	6.1, N2, CMR	73.4	PP, EP, TOX, A	6: +14°C, 17, 301, 304
1648	ACETONITRILE (methyl cyanide)	3	F1	II	3	97.0	PP, EX, A	
1662	NITROBENZENE	6.1	T1	II	6.1, N2	95.0	PP, EP, EX, TOX, A	6: +10 °C, 17
1663	NITROPHENOLS	6.1	T2	III	6.1, N3, S	95.0	PP, EP, EX, TOX, A	7, 17, 302, 304
1663	NITROPHENOLS	6.1	T2	III	6.1, N3, S	95.0	PP, EP, TOX, A	7, 17, 20: +65°C, 302, 304
1664	NITROTOLUENES, LIQUID (o-NITROTOLUENE)	6.1	T1	II	6.1, N2, CMR, S	95.0	PP, EP, TOX, A	
1708	TOLUIDINES, LIQUID (o-TOLUIDINE)	6.1	T1	II	6.1, N1, CMR	95.0	PP, EP, TOX, A	
1708	TOLUIDINES, LIQUID (m-TOLUIDINE)	6.1	T1	II	6.1, N1	95.0	PP, EP, TOX, A	
1710	TRICHLOROETHYLENE	6.1	T1	III	6.1, N2, CMR	95.0	PP, EP, TOX, A	15, 301, 303
1715	ACETIC ANHYDRIDE	8	CF1	II	3, 8	97.0	PP, EP, EX, A	34, 301
1718	BUTYL ACIDE PHOSPHATE	8	C3	III	8, N3	97.0	PP, EP	34
1719	CAUSTIC ALKALI LIQUID, N.O.S.(vP50 <= 12,5 kPa)	8	C5	II	8 + (N1, N2, N3, CMR, F or S)	97.0	PP, EP, TOX, A	22, 27, 30, 34, 302, 304
1719	CAUSTIC ALKALI LIQUID, N.O.S.	8	C5	III	8 + (N1, N2, N3, CMR, F or S)	97.0	PP, EP, TOX, A	22, 27, 34, 302, 304
1719	CAUSTIC ALKALI LIQUID, N.O.S.(vP50 > 12,5 kPa)	8	C5	II	8 + (N1, N2, N3, CMR, F or S)	10.0	PP, EP, TOX, A	22, 27, 30, 34, 302, 304
1738	BENZYL CHLORIDE	6.1	TC1	II	3, 6.1, 8, N3, CMR, S	95.0	PP, EP, EX, TOX, A	301, 303
1742	BORON TRIFLUORIDE ACETIC ACID COMPLEX, LIQUID	8	C3	II	8	97.0	PP, EP	34, 302, 304
1760	CORROSIVE LIQUID, N.O.S.(vP50 > 12,5 kPa)	8	C9	I	8 + (N1, N2, N3, CMR, F or S)	97.0	PP, EP, TOX, A	22, 27, 30, 34, 302, 304
1760	CORROSIVE LIQUID, N.O.S.(vP50 > 12,5 kPa)	8	C9	II	8 + (N1, N2, N3, CMR, F or S)	97.0	PP, EP, TOX, A	22, 27, 30, 34, 302, 304
1760	CORROSIVE LIQUID, N.O.S.	8	C9	III	8 + (N1, N2, N3, CMR, F or S)	97.0	PP, EP, TOX, A	22, 27, 34, 302, 304
1760	CORROSIVE LIQUID, N.O.S. (SODIUM MERCAPTOTHIAZOLE, 50% AQUEOUS SOLUTION)	8	C9	II	8, N1, F	95.0	PP, EP	34, 302

UN	Description	Class	Classification code	Packing group	Dangers	%	Equipment	Remarks
1760	CORROSIVE LIQUID, N.O.S. (FATTY ALCOHOL, C12-C14)	8	C9	III	8, F	97.0	PP, EP	34, 302
1760	CORROSIVE LIQUID, N.O.S. (ETHYLENE DIAMINETETRAACETIC ACID, TETRASODIUM SALT, 40% AQUEOUS SOLUTION)	8	C9	III	8, N2	97.0	PP, EP	34, 302, 304
1760	CORROSIVE LIQUID, N.O.S.(vp50 <= 12,5 kPa)	8	C9	II	8 + (N1, N2, N3, CMR, F or S)	97.0	PP, EP, TOX, A	22, 27, 30, 34, 302, 304
1760	CORROSIVE LIQUID, N.O.S.(vp50 <= 12,5 kPa)	8	C9	I	8 + (N1, N2, N3, CMR, F or S)	97.0	PP, EP, TOX, A	22, 27, 34, 302, 304
1779	FORMIC ACID WITH MORE THAN 85% acid by mass	8	CF1	II	3, 8, N3	97.0	PP, EP, EX, A	6: +12°C, 17, 34, 301, 304
1783	HEXAMETHYLENEDIAMINE SOLUTION	8	C7	II	8, N3	97.0	PP, EP, EX, A	7, 17, 34
1783	HEXAMETHYLENEDIAMINE SOLUTION	8	C7	III	8, N3	97.0	PP, EP, EX, A	7, 17, 34
1805	PHOSPHORIC ACID, SOLUTION, WITH MORE THAN 80% (VOLUME) ACID	8	C1	III	8	95.0	PP, EP	7, 17, 22, 34, 301
1805	PHOSPHORIC ACID, SOLUTION, WITH 80% (VOLUME) ACID, OR LESS	8	C1	III	8	97.0	PP, EP	22, 34, 301
1814	POTASSIUM HYDROXIDE SOLUTION	8	C5	II	8, N3	97.0	PP, EP	30, 34, 301
1814	POTASSIUM HYDROXIDE SOLUTION	8	C5	III	8, N3	97.0	PP, EP	30, 34, 301
1824	SODIUM HYDROXIDE SOLUTION	8	C5	II	8, N3	97.0	PP, EP	30, 34, 301
1824	SODIUM HYDROXIDE SOLUTION	8	C5	III	8, N3	97.0	PP, EP	30, 34, 301
1830	SULPHURIC ACID with more than 92% acid	8	C1	II	8, N3	97.0	PP, EP	8, 22, 30, 34, 301
1830	SULPHURIC ACID with more than 98% acid	8	C1	II	8, N3	97.0	PP, EP	8, 22, 30, 34, 301
1831	SULPHURIC ACID, FUMING	8	CT1	I	6.1, 8	82.5	PP, EP, TOX, A	8, 301, 304
1846	CARBON TETRACHLORIDE	6.1	T1	II	6.1, N2, S	95.0	PP, EP, TOX, A	23, 301, 304
1848	PROPIONIC ACID with not less than 10% and less than 90% acid by mass	8	C3	III	8, N3	97.0	PP, EP	34, 301, 303
1863	FUEL, AVIATION, TURBINE ENGINE WITH MORE THAN 10% BENZENE 60 °C < INITIAL BOILING POINT =< 85 °C	3	F1	III	3, CMR, F + (N1, N2, N3)	95.0	PP, EP, EX, TOX, A	23, 38

UN	Description	Class	Classification code	Packing group	Dangers	%	Equipment	Remarks
1863	FUEL, AVIATION, TURBINE ENGINE WITH MORE THAN 10% BENZENE 85 °C < INITIAL BOILING POINT =< 115 °C	3	F1	III	3, CMR, F + (N1, N2, N3)	95.0	PP, EP, EX, TOX, A	
1863	FUEL, AVIATION, TURBINE ENGINE WITH MORE THAN 10% BENZENE INITIAL BOILING POINT > 115 °C	3	F1	III	3, CMR, F + (N1, N2, N3)	95.0	PP, EP, EX, TOX, A	
1863	FUEL, AVIATION, TURBINE ENGINE (Flash point < 23°C with 110 kPa<=vP50<175 kPa)	3	F1	I	3 + (N1, N2, N3, CMR, F)	97.0	PP, EP, EX, TOX, A	14, 22
1863	FUEL, AVIATION, TURBINE ENGINE (Flash point < 23°C with 110 kPa<=vP50<175 kPa)	3	F1	II	3 + (N1, N2, N3, CMR, F)	97.0	PP, EP, EX, TOX, A	14, 22
1863	FUEL, AVIATION, TURBINE ENGINE (Flash point < 23°C with 110 kPa<=vP50<150 kPa)	3	F1	II	3 + (N1, N2, N3, CMR, F)	97.0	PP, EP, EX, TOX, A	14, 22
1863	FUEL, AVIATION, TURBINE ENGINE (Flash point < 23°C with 110 kPa<=vP50<150 kPa)	3	F1	I	3 + (N1, N2, N3, CMR, F)	97.0	PP, EP, EX, TOX, A	14, 22
1863	FUEL, AVIATION, TURBINE ENGINE (Flash point < 23°C with vP50<110 kPa)	3	F1	I	3 + (N1, N2, N3, CMR, F)	97.0	PP, EP, EX, TOX, A	14, 22
1863	FUEL, AVIATION, TURBINE ENGINE (Flash point < 23°C with vP50<110 kPa)	3	F1	II	3 + (N1, N2, N3, CMR, F)	97.0	PP, EP, EX, TOX, A	14, 22
1863	FUEL, AVIATION, TURBINE ENGINE (Flash point >= 23°C but <= 60 °C)	3	F1	III	3 + (N1, N2, N3, CMR, F)	97.0	PP, EP, EX, TOX, A	14, 22
1863	FUEL, AVIATION, TURBINE ENGINE WITH MORE THAN 10% BENZENE (Flash point < 23°C with 60 °C < BOILING POINT =< 85 °C)	3	F1	I	3, CMR, F + (N1, N2, N3)	95.0	PP, EP, EX, TOX, A	22, 23
1863	FUEL, AVIATION, TURBINE ENGINE WITH MORE THAN 10% BENZENE (Flash point < 23°C with 60 °C < BOILING POINT =< 85 °C)	3	F1	II	3, CMR, F + (N1, N2, N3)	95.0	PP, EP, EX, TOX, A	22, 23
1863	FUEL, AVIATION, TURBINE ENGINE WITH MORE THAN 10% BENZENE (60 °C < BOILING POINT =< 85 °C)	3	F1	III	CMR, F + (N1, N2, N3)	95.0	PP, EP, EX, TOX, A	22, 23
1863	FUEL, AVIATION, TURBINE ENGINE WITH MORE THAN 10% BENZENE (Flash point < 23°C with 85 °C < BOILING POINT =< 115 °C)	3	F1	I	3, CMR, F + (N1, N2, N3)	95.0	PP, EP, EX, TOX, A	22
1863	FUEL, AVIATION, TURBINE ENGINE WITH MORE THAN 10% BENZENE (Flash point < 23°C with 85 °C < BOILING POINT =< 115 °C)	3	F1	II	3, CMR, F + (N1, N2, N3)	95.0	PP, EP, EX, A	22
1863	FUEL, AVIATION, TURBINE ENGINE WITH MORE THAN 10% BENZENE (85 °C < BOILING POINT =< 115 °C)	3	F1	III	3, CMR, F + (N1, N2, N3)	95.0	PP, EP, EX, TOX, A	22

UN	Description	Class	Classification code	Packing group	Dangers	%	Equipment	Remarks
1863	FUEL, AVIATION, TURBINE ENGINE WITH MORE THAN 10% BENZENE (Flash point < 23°C with BOILING POINT > 115 °C)	3	F1	I	3, CMR, F + (N1, N2, N3)	95.0	PP, EP, EX, TOX, A	22
1863	FUEL, AVIATION, TURBINE ENGINE WITH MORE THAN 10% BENZENE (Flash point < 23°C with BOILING POINT > 115 °C)	3	F1	II	3, CMR, F + (N1, N2, N3)	95.0	PP, EP, EX, TOX, A	22
1863	FUEL, AVIATION, TURBINE ENGINE WITH MORE THAN 10% BENZENE (BOILING POINT > 115 °C)	3	F1	III	3, CMR, F + (N1, N2, N3)	95.0	PP, EP, EX, TOX, A	22
1863	FUEL, AVIATION, TURBINE ENGINE WITH MORE THAN 10% BENZENE (According ADN 3.2.3.3 – Scheme A – Criteria for cargo tank equipment in vessels of Type C)	3	F1	I	3, N1, N2, N3, CMR, F	95.0	PP, EP, EX, TOX, A	22, 23, 98
1863	FUEL, AVIATION, TURBINE ENGINE WITH MORE THAN 10% BENZENE (According ADN 3.2.3.3 – Scheme A – Criteria for cargo tank equipment in vessels of Type C)	3	F1	II	3, N1, N2, N3, CMR, F	95.0	PP, EP, EX, TOX, A	22, 23, 98
1888	CHLOROFORM	6.1	T1	III	6.1, N2, CMR	95.0	PP, EP, TOX, A	23, 302, 303
1897	TETRACHLOROETHYLENE	6.1	T1	III	6.1, N2, S	95.0	PP, EP, TOX, A	301, 303
1915	CYCLOHEXANONE	3	F1	III	3	97.0	PP, EX, A	
1917	ETHYL ACRYLATE, STABILIZED	3	F1	II	3, unst., N3	95.0	PP, EX, A	3, 5, 301, 303
1918	ISOPROPYLBENZENE (cumene)	3	F1	III	3, N2	97.0	PP, EX, A	
1919	METHYL ACRYLATE, STABILIZED	3	F1	II	3, unst., N3	95.0	PP, EX, A	3, 5, 23, 301, 303
1920	NONANES	3	F1	III	3, N2, F	97.0	PP, EX, A	
1922	PYRROLIDINE	3	FC	II	3, 8	95.0	PP, EP, EX, A	301
1986	ALCOHOLS, FLAMMABLE, TOXIC, N.O.S. (Flash point < 23°C with 60 °C < boiling point =< 85 °C)	3	FT1	II	3, 6.1 + (N1, N2, N3, CMR, F or S)	95.0	PP, EP, EX, TOX, A	22, 23, 27, 301
1986	ALCOHOLS, FLAMMABLE, TOXIC, N.O.S. (Flash point < 23°C with 85 °C < boiling point =< 115 °C)	3	FT1	II	3, 6.1 + (N1, N2, N3, CMR, F or S)	95.0	PP, EP, EX, TOX, A	22, 27, 301
1986	ALCOHOLS, FLAMMABLE, TOXIC, N.O.S. (Flash point < 23°C with boiling point > 115 °C)	3	FT1	II	3, 6.1 + (N1, N2, N3, CMR, F or S)	95.0	PP, EP, EX, TOX, A	22, 27, 301
1986	ALCOHOLS, FLAMMABLE, TOXIC, N.O.S. (60 °C < boiling point =< 85 °C)	3	FT1	III	3, 6.1 + (N1, N2, N3, CMR, F or S)	95.0	PP, EP, EX, TOX, A	22, 23, 27, 301

UN	Description	Class	Classification code	Packing group	Dangers	%	Equipment	Remarks
1986	ALCOHOLS, FLAMMABLE, TOXIC, N.O.S. (85 °C < boiling point =< 115 °C)	3	FT1	III	3, 6.1 + (N1, N2, N3, CMR, F or S)	95.0	PP, EP, EX, TOX, A	22, 27, 301
1986	ALCOHOLS, FLAMMABLE, TOXIC, N.O.S. (boiling point > 115 °C)	3	FT1	III	3, 6.1 + (N1, N2, N3, CMR, F or S)	95.0	PP, EP, EX, TOX, A	22, 27, 301
1986	ALCOHOLS, FLAMMABLE, TOXIC, N.O.S. (Flash point < 23°C with 85 °C < boiling point =< 115 °C)	3	FT1	I	3, 6.1 + (N1, N2, N3, CMR, F or S)	95.0	PP, EP, EX, TOX, A	22, 27, 301
1986	ALCOHOLS, FLAMMABLE, TOXIC, N.O.S. (Flash point < 23°C with 60 °C < boiling point =< 85 °C)	3	FT1	I	3, 6.1 + (N1, N2, N3, CMR, F or S)	95.0	PP, EP, EX, TOX, A	22, 23, 27, 301
1986	ALCOHOLS, FLAMMABLE, TOXIC, N.O.S. (Flash point < 23°C with boiling point > 115 °C)	3	FT1	I	3, 6.1 + (N1, N2, N3, CMR, F or S)	95.0	PP, EP, EX, TOX, A	22, 27, 301
1987	ALCOHOLS, N.O.S. (TERTBUTANOL 90 % (MASS)/METHANOL 10 % (MASS) MIXTURE)	3	F1	II	3	97.0	PP, EX, A	301
1987	ALCOHOLS, N.O.S. (Flash point >= 23°C but <= 60 °C)	3	F1	III	3 + (N1, N2, N3, CMR, F or S)	97.0	PP, EP, EX, TOX, A	14, 22, 27, 301
1987	ALCOHOLS, N.O.S. (CYCLOHEXANOL)	3	F1	III	3, N3, F	95.0	PP, EX, A	7, 17, 301
1987	ALCOHOLS, N.O.S. (CYCLOHEXANOL)	3	F1	III	3, N3, F	95.0	PP	7, 17, 20, 301
1987	ALCOHOLS, N.O.S. (Flash point < 23°C with 110 kPa<=vP50<175 kPa)	3	F1	II	3 + (N1, N2, N3, CMR, F or S)	97.0	PP, EP, EX, TOX, A	14, 22, 27, 301
1987	ALCOHOLS, N.O.S. (Flash point < 23°C with 110 kPa<=vP50<150 kPa)	3	F1	II	3 + (N1, N2, N3, CMR, F or S)	97.0	PP, EP, EX, TOX, A	14, 22, 27, 301
1987	ALCOHOLS, N.O.S. (Flash point < 23°C with vP50<110 kPa)	3	F1	II	3 + (N1, N2, N3, CMR, F or S)	97.0	PP, EP, EX, TOX, A	14, 22, 27, 301
1989	ALDEHYDES N.O.S. (Flash point >= 23°C but <= 60 °C)	3	F1	III	3 + (N1, N2, N3, CMR, F or S)	97.0	PP, EP, EX, TOX, A	14, 22, 27
1989	ALDEHYDES, FLAMMABLE, N.O.S. (Flash point < 23°C with 110 kPa<=vP50<175 kPa)	3	F1	II	3 + (N1, N2, N3, CMR, F or S)	97.0	PP, EP, EX, TOX, A	14, 22, 27
1989	ALDEHYDES, FLAMMABLE, N.O.S. (Flash point < 23°C with 110 kPa<=vP50<150 kPa)	3	F1	II	3 + (N1, N2, N3, CMR, F or S)	97.0	PP, EP, EX, TOX, A	14, 22, 27
1989	ALDEHYDES, FLAMMABLE, N.O.S. (Flash point < 23°C with vP50<110 kPa)	3	F1	II	3 + (N1, N2, N3, CMR, F or S)	97.0	PP, EP, EX, TOX, A	14, 22, 27

UN	Description	Class	Classification code	Packing group	Dangers	%	Equipment	Remarks
1991	CHLOROPRENE, STABILIZED	3	FT1	I	3, 6.1, unst., CMR	95.0	PP, EP, EX, TOX, A	3, 5, 23, 301, 303
1992	FLAMMABLE LIQUID, TOXIC, N.O.S. (Flash point < 23°C with 60 °C < boiling point =< 85 °C)	3	FT1	II	3, 6.1, N1, N2, N3, CMR, F or S	95.0	PP, EP, EX, TOX, A	22, 23, 27, 302, 304
1992	FLAMMABLE LIQUID, TOXIC, N.O.S. (Flash point < 23°C with 85 °C < boiling point =< 115 °C)	3	FT1	II	3, 6.1, N1, N2, N3, CMR, F or S	95.0	PP, EP, EX, TOX, A	22, 27, 302, 304
1992	FLAMMABLE LIQUID, TOXIC, N.O.S. (Flash point < 23°C with boiling point > 115°C)	3	FT1	II	3, 6.1, N1, N2, N3, CMR, F or S	95.0	PP, EP, EX, TOX, A	22, 27, 302, 304
1992	FLAMMABLE LIQUID, TOXIC, N.O.S. (60 °C < boiling point =< 85 °C)	3	FT1	III	3, 6.1, N1, N2, N3, CMR, F or S	95.0	PP, EP, EX, TOX, A	22, 23, 27, 302, 304
1992	FLAMMABLE LIQUID, TOXIC, N.O.S. (85 °C < boiling point =< 115 °C)	3	FT1	III	3, 6.1, N1, N2, N3, CMR, F or S	95.0	PP, EP, EX, TOX, A	27, 302, 304
1992	FLAMMABLE LIQUID, TOXIC, N.O.S.(boiling point > 115°C)	3	FT1	III	3, 6.1, N1, N2, N3, CMR, F or S	95.0	PP, EP, EX, TOX, A	22, 27, 302, 304
1992	FLAMMABLE LIQUID, TOXIC, N.O.S. (Flash point < 23°C with 60 °C < boiling point =< 85 °C)	3	FT1	I	3, 6.1, N1, N2, N3, CMR, F or S	95.0	PP, EP, EX, TOX, A	22, 23, 27, 302, 304
1992	FLAMMABLE LIQUID, TOXIC, N.O.S. (Flash point < 23°C with 85 °C < boiling point =< 115 °C)	3	FT1	I	3, 6.1, N1, N2, N3, CMR, F or S	95.0	PP, EP, EX, TOX, A	22, 27, 302, 304
1992	FLAMMABLE LIQUID, TOXIC, N.O.S. (Flash point < 23°C with boiling point > 115°C)	3	FT1	I	3, 6.1, N1, N2, N3, CMR, F or S	95.0	PP, EP, EX, TOX	22, 27, 302, 304
1993	FLAMMABLE LIQUID, N.O.S. WITH MORE THAN 10% BENZENE 60 °C < INITIAL BOILING POINT =< 85 °C	3	F1	II	3 + (N1, N2, N3, CMR, F)	95.0	PP, EP, EX, TOX, A	23, 38, 302, 304
1993	FLAMMABLE LIQUID, N.O.S. WITH MORE THAN 10% BENZENE 85 °C < INITIAL BOILING POINT =< 115 °C	3	F1	II	3 + (N1, N2, N3, CMR, F)	95.0	PP, EP, EX, TOX, A	302, 304
1993	FLAMMABLE LIQUID, N.O.S. WITH MORE THAN 10% BENZENE INITIAL BOILING POINT > 115 °C	3	F1	II	3 + (N1, N2, N3, CMR, F)	95.0	PP, EP, EX, TOX, A	302, 304
1993	FLAMMABLE LIQUID, N.O.S.(Flash point >= 23°C but <= 60 °C)	3	F1	III	3 + (N1, N2, N3, CMR, F)	97.0	PP, EP, EX, TOX, A	14, 22, 27, 302, 304
1993	FLAMMABLE LIQUID, N.O.S. WITH MORE THAN 10% BENZENE 60 °C < INITIAL BOILING POINT =< 85 °C	3	F1	III	3 + (N1, N2, N3, CMR, F)	95.0	PP, EP, EX, TOX, A	23, 38, 302, 304

UN	Description	Class	Classification code	Packing group	Dangers	%	Equipment	Remarks
1993	FLAMMABLE LIQUID, N.O.S. WITH MORE THAN 10% BENZENE 85 °C < INITIAL BOILING POINT =< 115 °C	3	F1	III	3 + (N1, N2, N3, CMR, F)	95.0	PP, EP, EX, TOX, A	302, 304
1993	FLAMMABLE LIQUID, N.O.S. WITH MORE THAN 10% BENZENE INITIAL BOILING POINT > 115 °C	3	F1	III	3 + (N1, N2, N3, CMR, F)	95.0	PP, EP, EX, TOX, A	302, 304
1993	FLAMMABLE LIQUID, N.O.S. (CYCLOHEXANONE/CYCLOHEXANOL MIXTURE)	3	F1	III	3, F	97.0	PP, EP, EX, TOX, A	302
1993	FLAMMABLE LIQUID, N.O.S.(Flash point < 23°C with 110 kPa<=vP50<175 kPa)	3	F1	I	3 + (N1, N2, N3, CMR, F)	97.0	PP, EP, EX, TOX, A	14, 22, 27, 302, 304
1993	FLAMMABLE LIQUID, N.O.S.(Flash point < 23°C with 110 kPa<=vP50<175 kPa)	3	F1	II	3 + (N1, N2, N3, CMR, F)	97.0	PP, EP, EX, TOX, A	14, 22, 27, 302, 304
1993	FLAMMABLE LIQUID, N.O.S.(Flash point < 23°C with 110 kPa<=vP50<150 kPa)	3	F1	I	3 + (N1, N2, N3, CMR, F)	97.0	PP, EP, EX, TOX, A	14, 22, 27, 302, 304
1993	FLAMMABLE LIQUID, N.O.S.(Flash point < 23°C with 110 kPa<=vP50<150 kPa)	3	F1	II	3 + (N1, N2, N3, CMR, F)	97.0	PP, EP, EX, TOX, A	14, 22, 27, 302, 304
1993	FLAMMABLE LIQUID, N.O.S.(Flash point < 23°C with vP50<110 kPa)	3	F1	II	3 + (N1, N2, N3, CMR, F)	97.0	PP, EP, EX, TOX, A	14, 22, 27, 302, 304
1993	FLAMMABLE LIQUID, N.O.S.(Flash point < 23°C with vP50<110 kPa)	3	F1	I	3 + (N1, N2, N3, CMR, F)	97.0	PP, EP, EX, TOX, A	14, 22, 27, 302, 304
1993	FLAMMABLE LIQUID, N.O.S. WITH MORE THAN 10% BENZENE (Flash point < 23°C with 60 °C < BOILING POINT =< 85 °C)	3	F1	I	3 + (N1, N2, N3, CMR, F)	95.0	PP, EP, EX, TOX, A	22, 23, 27, 302, 304
1993	FLAMMABLE LIQUID, N.O.S. WITH MORE THAN 10% BENZENE (Flash point < 23°C with 60 °C < BOILING POINT =< 85 °C)	3	F1	II	3 + (N1, N2, N3, CMR, F)	95.0	PP, EP, EX, TOX, A	22, 23, 27, 302, 304
1993	FLAMMABLE LIQUID, N.O.S. WITH MORE THAN 10% BENZENE (60 °C < BOILING POINT =< 85 °C)	3	F1	III	3 + (N1, N2, N3, CMR, F)	95.0	PP, EP, EX, TOX, A	22, 23, 27, 302, 304
1993	FLAMMABLE LIQUID, N.O.S. WITH MORE THAN 10% BENZENE (Flash point < 23°C with 85 °C < BOILING POINT =< 115 °C)	3	F1	I	3 + (N1, N2, N3, CMR, F)	95.0	PP, EP, EX, TOX, A	22, 27, 302, 304
1993	FLAMMABLE LIQUID, N.O.S. WITH MORE THAN 10% BENZENE (Flash point < 23°C with 85 °C < BOILING POINT =< 115 °C)	3	F1	II	3 + (N1, N2, N3, CMR, F)	95.0	PP, EP, EX, TOX, A	22, 27, 302, 304
1993	FLAMMABLE LIQUID, N.O.S. WITH MORE THAN 10% BENZENE (85 °C < BOILING POINT =< 115 °C)	3	F1	III	3 + (N1, N2, N3, CMR, F)	95.0	PP, EP, EX, TOX, A	22, 27, 302, 304

UN	Description	Class	Classification code	Packing group	Dangers	%	Equipment	Remarks
1993	FLAMMABLE LIQUID, N.O.S. WITH MORE THAN 10% BENZENE (Flash point < 23°C with BOILING POINT > 115 °C)	3	F1	I	3 + (N1, N2, N3, CMR, F)	95.0	PP, EP, EX, TOX, A	22, 27, 302, 304
1993	FLAMMABLE LIQUID, N.O.S. WITH MORE THAN 10% BENZENE (Flash point < 23°C with BOILING POINT > 115 °C)	3	F1	II	3 + (N1, N2, N3, CMR, F)	95.0	PP, EP, EX, TOX, A	22, 27, 302, 304
1993	FLAMMABLE LIQUID, N.O.S. WITH MORE THAN 10% BENZENE (BOILING POINT > 115 °C)	3	F1	III	3 + (N1, N2, N3, CMR, F)	95.0	PP, EP, EX, TOX, A	22, 27, 302, 304
1993	FLAMMABLE LIQUID, N.O.S. WITH MORE THAN 10% BENZENE (According ADN 3.2.3.3 – Scheme A – Criteria for cargo tank equipment in vessels of Type C)	3	F1	I	3 + (N1, N2, N3, CMR, F)	95.0	PP, EP, EX, TOX, A	22, 23, 27, 98, 302, 304
1993	FLAMMABLE LIQUID, N.O.S. WITH MORE THAN 10% BENZENE (According ADN 3.2.3.3 – Scheme A – Criteria for cargo tank equipment in vessels of Type C)	3	F1	II	3 + (N1, N2, N3, CMR, F)	95.0	PP, EP, EX, TOX, A	22, 23, 27, 98, 302, 304
1999	TARS, LIQUID, including road oils and cutback bitumens	3	F1	III	3, S	97.0	PP, EX, A	301
2021	CHLOROPHENOLS, LIQUID (2-CHLOROPHENOL)	6.1	T1	III	6.1, N2	95.0	PP, EP, EX, TOX, A	6: +10°C, 17, 301, 303
2022	CRESILIC ACID	6.1	TC1	II	3, 6.1, 8, S	95.0	PP, EP, EX, TOX, A	6: +16°C, 17, 301
2023	EPICHLORHYDRIN	6.1	TF1	II	3, 6.1, N3	95.0	PP, EP, EX, TOX, A	5, 301, 304
2031	NITRIC ACID, other than red fuming, with not more than 65% acid	8	CO1	II	8, N3	97.0	PP, EP	34, 301
2031	NITRIC ACID, other than red fuming with more than 65% acid but not more than 70% acid	8	CO1	II	8, N3	97.0	PP, EP	34, 301, 304
2045	ISOBUTYRALDEHYDE (ISOBUTYL ALDEHYDE)	3	F1	II	3, N3	95.0	PP, EX, A	15, 23, 301
2046	CYMENES	3	F1	III	3, N2, F	97.0	PP, EX, A	
2047	DICHLOROPROPENES (2,3-DICHLOROPROP-1-ENE)	3	F1	II	3, N2, CMR	95.0	PP, EP, EX, TOX, A	301, 303
2047	DICHLOROPROPENES (MIXTURES OF 2,3-DICHLOROPROP-1-ENE AND 1,3-DICHLOROPROP-1-ENE)	3	F1	II	3, N1, N2, CMR	95.0	PP, EP, EX, TOX, A	301, 303
2047	DICHLOROPROPENES (MIXTURES OF 2,3-DICHLOROPROP-1-ENE AND 1,3-DICHLOROPROP-1-ENE)	3	F1	III	3, N1, N2, CMR	95.0	PP, EP, EX, TOX, A	301, 303
2047	DICHLOROPROPENES (1,3-DICHLOROPROP-1-ENE)	3	F1	III	3, N1, N2, CMR	95.0	PP, EP, EX, TOX, A	301, 303
2048	DICYCLOPENTADIENE	3	F1	III	3, N2, F	95.0	PP, EX, A	7, 17

UN	Description	Class	Classification code	Packing group	Dangers	%	Equipment	Remarks
2050	DIISOBUTYLENE, ISOMERIC COMPOUNDS	3	F1	II	3, N2, F	97.0	PP, EX, A	
2051	2-DIMETHYLAMINOETHANOL	8	CF1	II	3, 8, N3	97.0	PP, EP, EX, A	34, 301
2053	METHYL ISOBUTYL CARBINOL	3	F1	III	3	97.0	PP, EX, A	301
2054	MORPHOLINE	8	CF1	I	3, 8, N3	97.0	PP, EP, EX, A	34
2055	STYRENE MONOMER, STABILIZED	3	F1	III	3, unst., N3	97.0	PP, EX, A	3, 5, 16, 301, 303
2056	TETRAHYDROFURAN	3	F1	II	3	97.0	PP, EX, A	
2057	TRIPROPYLENE	3	F1	III	3, N1	95.0	PP, EX, A	
2057	TRIPROPYLENE	3	F1	II	3, N1	95.0	PP, EX, A	
2078	TOLUENE DIISOCYANATE (and isomeric mixtures)(2,4-TOLUENE DIISOCYANATE)	6.1	T1	II	6.1, N2, S	95.0	PP, EP, EX, TOX, A	2, 7, 8, 17, 301, 303
2079	DIETHYLENETRIAMINE	8	C7	II	8, N3	97.0	PP, EP	34, 301
2205	ADIPONITRILE	6.1	T1	III	6.1	95.0	PP, EP, EX, TOX, A	6, 17
2206	ISOCYANATES, TOXIC, N.O.S. (4-CHLOROPHENYL ISOCYANATE)	6.1	T1	II	6.1, S	95.0	PP, EP, TOX, A	7, 17, 301, 303
2209	FORMALDEHYDE SOLUTION with not less than 25% formaldehyde	8	C9	III	8, N3	97.0	PP, EP	15, 34, 301
2215	MALEIC ANHYDRIDE, MOLTEN	8	C3	III	8, N3	95.0	PP, EP, EX, A	7, 17, 34, 301
2218	ACRYLIC ACID, STABILIZED	8	CF1	II	3, 8, unst., N1	95.0	PP, EP, EX, A	3, 4, 5, 17, 301, 303
2227	n-BUTYL METHACRYLATE, STABILIZED	3	F1	III	3, unst., N3, F	95.0	PP, EX, A	3, 5, 301, 303
2238	CHLOROTOLUENES (m-CHLOROTOLUENE)	3	F1	III	3, N2, S	95.0	PP, EX, A	301, 303
2238	CHLOROTOLUENES (o-CHLOROTOLUENE)	3	F1	III	3, N2, S	95.0	PP, EX, A	301, 303
2238	CHLOROTOLUENES (p-CHLOROTOLUENE)	3	F1	III	3, N2, S	95.0	PP, EX, A	6: +11°C, 17, 301, 303
2241	CYCLOHEPTANE	3	F1	II	3, N2	97.0	PP, EX, A	
2247	n-DECANE	3	F1	III	3, F	95.0	PP, EX, A	
2248	DI-n-BUTYLAMINE	8	CF1	II	3, 8, N3	97.0	PP, EP, EX, A	34, 301
2259	TRIETHYLENETETRAMINE	8	C7	II	8, N2	97.0	PP, EP, EX, A	6: 16 °C, 34, 301
2263	DIMETHYLCYCLOHEXANES (trans-1,4-DIMETHYLCYCLOHEXANES)	3	F1	II	3	95.0	PP, EX, A	
2263	DIMETHYLCYCLOHEXANES (cis-1,4-DIMETHYLCYCLOHEXANES)	3	F1	II	3	95.0	PP, EX, A	

UN	Description	Class	Classification code	Packing group	Dangers	%	Equipment	Remarks
2264	N,N-DIMETHYLCYCLOHEXYLAMINE	8	CF1	II	3, 8, N2	97.0	PP, EP, EX, A	34
2265	N,N-DIMETHYLFORMAMIDE	3	F1	III	3, CMR	97.0	PP, EP, EX, TOX, A	
2266	DIMETHYL-N-PROPYLAMINE	3	FC	II	3, 8	95.0	PP, EP, EX, A	23, 301
2276	2-ETHYLHEXYLAMINE	3	FC	III	3, 8, N3	97.0	PP, EP, EX, A	34, 301
2278	n-HEPTENE	3	F1	II	3, N3	97.0	PP, EX, A	
2280	HEXAMETHYLENEDIAMINE, SOLID, MOLTEN	8	C8	III	8, N3	95.0	PP, EP, EX, A	7, 17, 34, 301
2280	HEXAMETHYLENEDIAMINE, SOLID, MOLTEN	8	C8	III	8, N3	95.0	PP, EP	7, 17, 20: +66°C, 34, 301
2282	HEXANOLS	3	F1	III	3, N3	97.0	PP, EX, A	301
2286	PENTAMETHYLHEPTANE	3	F1	III	3, F	97.0	PP, EX, A	
2288	ISOHEXENES	3	F1	II	3, unst., N3	95.0	PP, EX, A	3, 23
2289	ISOPHORONEDIAMINE	8	C7	III	8, N2	97.0	PP, EP, EX, A	6, 17, 34, 301
2302	5-METHYLHEXAN-2-ONE	3	F1	III	3	97.0	PP, EX, A	
2303	ISOPROPENYL BENZENE	3	F1	III	3, N2, F	97.0	PP, EX, A	301, 303
2309	OCTADIENE (1,7-OCTANDIENE)	3	F1	II	3, N2	97.0	PP, EX, A	
2311	PHENETIDINES	6.1	T1	III	6.1	95.0	PP, EP, TOX, A	6: +7°C, 17
2312	PHENOL, MOLTEN	6.1	T1	II	6.1, N3, S	95.0	PP, EP, EX, TOX, A	7, 17, 301
2312	PHENOL, MOLTEN	6.1	T1	II	6.1, N3, S	95.0	PP, EP, TOX, A	7, 17, 20: +67°C, 301
2320	TETRAETHYLENEPENTAMINE	8	C7	III	8, N2	97.0	PP, EP	34, 301
2323	TRIETHYL PHOSPHITE	3	F1	III	3	97.0	PP, EX, A	301
2324	TRISOBUTYLENE	3	F1	III	3, N1, F	95.0	PP, EX, A	
2325	1,3,5-TRIMETHYLBENZENE	3	F1	III	3, N1	95.0	PP, EX, A	
2333	ALLYL ACETATE	3	FT1	II	3, 6.1	95.0	PP, EP, EX, TOX, A	301
2348	BUTYL ACRYLATES, STABILIZED (n-BUTYLACRYLATE, STABILIZED)	3	F1	III	3, unst., N3	95.0	PP, EX, A	3, 5, 301, 303
2350	BUTYL METHYL ETHER	3	F1	II	3	97.0	PP, EX, A	
2356	2-CHLOROPROPANE	3	F1	I	3	95.0	PP, EX, A	23, 301, 303
2357	CYCLOHEXYLAMINE	8	CF1	II	3, 8, N3	97.0	PP, EP, EX, A	34

UN	Description	Class	Classification code	Packing group	Dangers	%	Equipment	Remarks
2362	1,1-DICHLOROETHANE	3	F1	II	3, N2	95.0	PP, EX, A	23, 301, 303
2370	1-HEXENE	3	F1	II	3, N3	97.0	PP, EX, A	
2381	DIMÉTHYL DISULPHIDE	3	FT1	II	3, 6.1	95.0	PP, EP, EX, TOX, A	301
2382	DIMETHYLHYDRAZINE, SYMMETRICAL	6.1	TF1	I	3, 6.1, CMR	95.0	PP, EP, EX, TOX, A	
2383	DIPROPYLAMINE	3	FC	II	3, 8, N3	95.0	PP, EP, EX, A	301
2397	3-METHYLBUTAN-2-ONE	3	F1	II	3	97.0	PP, EX, A	
2398	METHYL tert-BUTYL ETHER	3	F1	II	3	97.0	PP, EX, A	
2404	PROPIONITRILE	3	FT1	II	3, 6.1	95.0	PP, EP, EX, TOX, A	
2414	THIOPHENE	3	F1	II	3, N3, S	97.0	PP, EX, A	
2430	ALKYLPHENOLS, SOLID, N.O.S. (NONYLPHENOL, ISOMERIC MIXTURE, MOLTEN)	8	C4	II	8, N1, F	95.0	PP, EP	7, 17, 20: +125°C, 301
2432	N,N-DIETHYLANILINE	6.1	T1	III	6.1, N2	95.0	PP, EP, TOX, A	301
2458	HEXADIENES	3	F1	II	3, N3	97.0	PP, EX, A	
2477	METHYL ISOTHIOCYANATE	6.1	TF1	I	3, 6.1, N1	95.0	PP, EP, EX, TOX, A	7, 17, 301, 303
2485	n-BUTYL ISOCYANATE	6.1	TF1	I	3, 6.1	95.0	PP, EP, EX, TOX, A	301, 303
2486	ISOBUTYL ISOCYANATE	6.1	TF1	I	3, 6.1	95.0	PP, EP, EX, TOX, A	301, 303
2487	PHENYL ISOCYANATE	6.1	TF1	I	3, 6.1	95.0	PP, EP, EX, TOX, A	301, 303
2490	DICHLOROISOPROPYL ETHER	6.1	T1	II	6.1	95.0	PP, EP, TOX, A	301, 303
2491	ETHANOLAMINE or ETHANOLAMINE SOLUTION	8	C7	III	8, N3	97.0	PP, EP, EX, A	6: +14°C, 17, 34, 301
2493	HEXAMETHYLENEIMINE	3	FC	II	3, 8, N3	97.0	PP, EP, EX, A	34, 301
2496	PROPIONIC ANHYDRIDE	8	C3	III	8, N3	97.0	PP, EP	34, 301
2518	1,5,9-CYCLODODECATRIENE	6.1	T1	III	6.1, F	95.0	PP, EP, TOX, A	301, 303
2527	ISOBUTYL ACRYLATE, STABILIZED	3	F1	III	3, unst.	95.0	PP, EX, A	3, 5, 301, 303
2528	ISOBUTYL ISOBUTYRATE	3	F1	III	3, N3	97.0	PP, EX, A	
2531	METHACRYLIC ACID, STABILIZED	8	C3	II	8, unst., N3	95.0	PP, EP, EX, A	3, 4, 5, 17, 301, 303
2574	TRICRESYL PHOSPHATE with more than 3% ortho isomer	6.1	T1	II	6.1, N1, S	95.0	PP, EP, TOX, A	301

UN	Description	Class	Classification code	Packing group	Dangers	%	Equipment	Remarks
2579	PIPERAZINE, MOLTEN	8	C8	III	8, N2	95.0	PP, EP	7, 17, 34, 302
2586	ALKYLSULFONIC ACIDS, LIQUID or ARSULFONIC ACID, LIQUID with not more than 5% free sulphuric acid	8	C3	III	8	97.0	PP, EP	34, 301
2608	NITROPROPANES	3	F1	III	3	97.0	PP, EX, A	
2615	ETHYL PROPYL ETHER	3	F1	II	3	97.0	PP, EX, A	
2618	VINYLTOLUENES, STABILIZED	3	F1	III	3, unst., N2, F	95.0	PP, EX, A	3, 5, 301, 303
2651	4,4'-DIAMINODIPHENYLMETHANE	6.1	T2	III	6.1, N2, CMR, S	95.0	PP, EP, TOX, A	7, 17, 301, 304
2672	AMMONIA SOLUTION, relative density between 0.880 and 0.957 at 15 °C in water with more than 10% but not more than 35% ammonia (more than 25% but not more than 35% ammonia)	8	C5	III	8, N3	95.0	PP, EP	34
2683	AMMONIUM SULPHIDE SOLUTION	8	CFT	II	3, 6.1, 8	95.0	PP, EP, EX, TOX, A	15, 16, 301
2693	BISULPHITES, AQUEOUS SOLUTION, N.O.S.	8	C1	III	8	97.0	PP, EP	27, 34, 302, 304
2709	BUTYLBENZENES	3	F1	III	3, N1, F	97.0	PP, EX, A	
2709	BUTYLBENZENES (n-BUTYLBENZENE)	3	F1	III	3, N1, F	97.0	PP, EX, A	41
2733	AMINES, FLAMMABLE, CORROSIVE, N.O.S. or POLYAMINES, FLAMMABLE, CORROSIVE, N.O.S. (2-AMINOBUTANE)	3	FC	II	3, 8, N1	95.0	PP, EP, EX, A	23, 301
2735	AMINES, LIQUID, CORROSIVE, N.O.S. or POLYAMINES, LIQUID, CORROSIVE, N.O.S.(vP50 > 12,5 kPa)	8	C7	I	8 + (N1, N2, N3, CMR, F or S)	97.0	PP, EP, TOX, A	22, 27, 34, 301
2735	AMINES, LIQUID, CORROSIVE, N.O.S. or POLYAMINES, LIQUID, CORROSIVE, N.O.S.(vP50 > 6,0 kPa)	8	C7	III	8 + (N1, N2, N3, CMR, F or S)	97.0	PP, EP, TOX, A	22, 27, 34, 301
2735	AMINES, LIQUID, CORROSIVE, N.O.S. or POLYAMINES, LIQUID, CORROSIVE, N.O.S.(vP50 > 12,5 kPa)	8	C7	II	8 + (N1, N2, N3, CMR, F or S)	97.0	PP, EP, TOX, A	22, 27, 34, 301
2735	AMINES, LIQUID, CORROSIVE, N.O.S. or POLYAMINES, LIQUID, CORROSIVE, N.O.S.(vP50 <= 12,5 kPa)	8	C7	I	8 + (N1, N2, N3, CMR, F or S)	97.0	PP, EP, TOX, A	22, 27, 34, 301
2735	AMINES, LIQUID, CORROSIVE, N.O.S. or POLYAMINES, LIQUID, CORROSIVE, N.O.S.(vP50 <= 12,5 kPa)	8	C7	II	8 + (N1, N2, N3, CMR, F or S)	97.0	PP, EP, TOX, A	22, 27, 34, 301
2735	AMINES, LIQUID, CORROSIVE, N.O.S. or POLYAMINES, LIQUID, CORROSIVE, N.O.S.	8	C7	III	8 + (N1, N2, N3, CMR, F or S)	97.0	PP, EP, TOX, A	22, 27, 34, 301

UN	Description	Class	Classification code	Packing group	Dangers	%	Equipment	Remarks
2754	N-ETHYL-TOLUIDINES (N-ETHYL-o-TOLUIDINE)	6.1	T1	II	6.1, F	95.0	PP, EP, TOX, A	301
2754	N-ETHYL-TOLUIDINES (N-ETHYL-m-TOLUIDINE)	6.1	T1	II	6.1, F	95.0	PP, EP, TOX, A	301
2754	N-ETHYL-TOLUIDINES (N-ETHYL-o-TOLUIDINE and N-ETHYL-m-TOLUIDINE MIXTURES)	6.1	T1	II	6.1, F	95.0	PP, EP, TOX, A	301
2754	N-ETHYL-TOLUIDINES (N-ETHYL-p-TOLUIDINE)	6.1	T1	II	6.1, F	95.0	PP, EP, TOX, A	7, 17, 301
2785	4-THIAPENTANAL (3-MÉTHYLMERCAPTOPROPIONALDÉHYDE)	6.1	T1	III	6.1	95.0	PP, EP, TOX, A	
2789	ACETIC ACID, GLACIAL or ACETIC ACID SOLUTION, more than 80% acid, by mass	8	CF1	II	3, 8	95.0	PP, EP, EX, A	7, 17, 34, 301
2790	ACETIC ACID SOLUTION, not less than 50% but not more than 80% acid, by mass	8	C3	II	8	97.0	PP, EP	34, 301
2790	ACETIC ACID SOLUTION, more than 10% and less than 50% acid, by mass	8	C3	III	8	97.0	PP, EP	34, 301
2810	TOXIC LIQUID, ORGANIC, N.O.S. 60 °C < boiling point =< 85 °C	6.1	T1	I	6.1 + (N1, N2, N3, CMR, F or S)	95.0	PP, EP, TOX, A	22, 23, 27, 302, 304
2810	TOXIC LIQUID, ORGANIC, N.O.S. 85 °C < boiling point =< 115 °C	6.1	T1	I	6.1 + (N1, N2, N3, CMR, F or S)	95.0	PP, EP, TOX, A	22, 27, 302, 304
2810	TOXIC LIQUID, ORGANIC, N.O.S. boiling point > 115 °C	6.1	T1	I	6.1 + (N1, N2, N3, CMR, F or S)	95.0	PP, EP, TOX, A	22, 27, 302, 304
2810	TOXIC LIQUID, ORGANIC, N.O.S. 60 °C < boiling point =< 85 °C	6.1	T1	II	6.1 + (N1, N2, N3, CMR, F or S)	95.0	PP, EP, TOX, A	22, 23, 27, 302, 304
2810	TOXIC LIQUID, ORGANIC, N.O.S. 85 °C < boiling point =< 115 °C	6.1	T1	II	6.1 + (N1, N2, N3, CMR, F or S)	95.0	PP, EP, TOX, A	22, 27, 302, 304
2810	TOXIC LIQUID, ORGANIC, N.O.S. boiling point > 115 °C	6.1	T1	II	6.1 + (N1, N2, N3, CMR, F or S)	95.0	PP, EP, TOX, A	22, 27, 302, 304
2810	TOXIC LIQUID, ORGANIC, N.O.S. 60 °C < boiling point =< 85 °C	6.1	T1	III	6.1 + (N1, N2, N3, CMR, F or S)	95.0	PP, EP, TOX, A	22, 23, 27, 302, 304
2810	TOXIC LIQUID, ORGANIC, N.O.S. 85 °C < boiling point =< 115 °C	6.1	T1	III	6.1 + (N1, N2, N3, CMR, F or S)	95.0	PP, EP, TOX, A	22, 27, 302, 304

UN	Description	Class	Classification code	Packing group	Dangers	%	Equipment	Remarks
2810	TOXIC LIQUID, ORGANIC, N.O.S. boiling point > 115 °C	6.1	T1	III	6.1 + (N1, N2, N3, CMR, F or S)	95.0	PP, EP, TOX, A	22, 27, 302, 304
2815	N-AMINOETHYLPIPERAZINE	8	C7	III	8, N2	97.0	PP, EP	34, 301
2820	BUTYRIC ACID	8	C3	III	8, N3	97.0	PP, EP	34
2829	CAPROIC ACID	8	C3	III	8, N3	97.0	PP, EP	34
2831	1,1,1-TRICHLOROETHANE	6.1	T1	III	6.1, N2	95.0	PP, EP, TOX, A	23, 301, 303
2850	PROPYLENE TETRAMER	3	F1	III	3, N1, F	97.0	PP	
2874	FURFURYL ALCOHOL	6.1	T1	III	6.1, N3	95.0	PP, EP, TOX, A	301
2904	PHENOLATES, LIQUID	8	C9	III	8	97.0	PP, EP	34, 301
2920	CORROSIVE LIQUID, FLAMMABLE, N.O.S. (AQUEOUS SOLUTION OF HEXADECYLTRIMETHYLAMMONIUM CHLORIDE (50%) and ETHANOL (35%))	8	CF1	II	3, 8, F	95.0	PP, EP, EX, A	6: +7°C, 17, 34, 302, 304
2922	CORROSIVE LIQUID, TOXIC, N.O.S. 60 °C < boiling point =< 85 °C	8	CT1	I	6.1, 8, N1, N2, N3, CMR, F or S	95.0	PP, EP, TOX, A	22, 23, 27, 302, 304
2922	CORROSIVE LIQUID, TOXIC, N.O.S. 85 °C < boiling point =< 115 °C	8	CT1	I	6.1, 8, N1, N2, N3, CMR, F or S	95.0	PP, EP, TOX, A	22, 27, 302, 304
2922	CORROSIVE LIQUID, TOXIC, N.O.S. boiling point > 115 °C	8	CT1	I	6.1, 8, N1, N2, N3, CMR, F or S	95.0	PP, EP, TOX, A	22, 27, 302, 304
2922	CORROSIVE LIQUID, TOXIC, N.O.S. 60 °C < boiling point =< 85 °C	8	CT1	II	6.1, 8, N1, N2, N3, CMR, F or S	95.0	PP, EP, TOX, A	22, 23, 27, 302, 304
2922	CORROSIVE LIQUID, TOXIC, N.O.S. 85 °C < boiling point =< 115 °C	8	CT1	II	6.1, 8, N1, N2, N3, CMR, F or S	95.0	PP, EP, TOX, A	22, 27, 302, 304
2922	CORROSIVE LIQUID, TOXIC, N.O.S. boiling point > 115 °C	8	CT1	II	6.1, 8, N1, N2, N3, CMR, F or S	95.0	PP, EP, TOX, A	22, 27, 302, 304
2922	CORROSIVE LIQUID, TOXIC, N.O.S. 60 °C < boiling point =< 85 °C	8	CT1	III	6.1, 8, N1, N2, N3, CMR, F or S	95.0	PP, EP, TOX, A	22, 23, 27, 302, 304
2922	CORROSIVE LIQUID, TOXIC, N.O.S. 85 °C < boiling point =< 115 °C	8	CT1	III	6.1, 8, N1, N2, N3, CMR, F or S	95.0	PP, EP, TOX, A	22, 27, 302, 304
2922	CORROSIVE LIQUID, TOXIC, N.O.S. boiling point > 115 °C	8	CT1	III	6.1, 8, N1, N2, N3, CMR, F or S	95.0	PP, EP, TOX, A	22, 27, 302, 304

UN	Description	Class	Classification code	Packing group	Dangers	%	Equipment	Remarks
2924	FLAMMABLE LIQUID, CORROSIVE, N.O.S. (Flash point < 23°C with 60 °C < boiling point =< 85 °C)	3	FC	II	3, 8, N1, N2, N3, CMR, F or S	95.0	PP, EP, EX, TOX, A	22, 23, 27, 302, 304
2924	FLAMMABLE LIQUID, CORROSIVE, N.O.S. (Flash point < 23°C with 85 °C < boiling point =< 115 °C)	3	FC	II	3, 8, N1, N2, N3, CMR, F or S	95.0	PP, EP, EX, TOX, A	22, 27, 302, 304
2924	FLAMMABLE LIQUID, CORROSIVE, N.O.S. (Flash point < 23°C with boiling point > 115°C)	3	FC	II	3, 8, N1, N2, N3, CMR, F or S	95.0	PP, EP, EX, TOX, A	22, 27, 302, 304
2924	FLAMMABLE LIQUID, CORROSIVE, N.O.S. (Flash point >= 23°C but <= 60°C)	3	FC	III	3, 8 + (N1, N2, N3, CMR, F or S)	97.0	PP, EP, EX, TOX, A	22, 27, 34, 302, 304
2924	FLAMMABLE LIQUID, CORROSIVE, N.O.S. (AQUEOUS SOLUTION OF DIALKYL-(C8-C18)-DIMETHYLAMMONIUM CHLORIDE and 2-PROPANOL)	3	FC	II	3, 8, F	95.0	PP, EP, EX, A	302, 304
2924	FLAMMABLE LIQUID, CORROSIVE, N.O.S. (Flash point < 23°C with boiling point > 115°C)	3	FC	I	3, 8, N1, N2, N3, CMR, F or S	95.0	PP, EP, EX, TOX, A	22, 27, 302, 304
2924	FLAMMABLE LIQUID, CORROSIVE, N.O.S. (Flash point < 23°C with 85 °C < boiling point =< 115 °C)	3	FC	I	3, 8, N1, N2, N3, CMR, F or S	95.0	PP, EP, EX, TOX, A	22, 27, 302, 304
2924	FLAMMABLE LIQUID, CORROSIVE, N.O.S. (Flash point < 23°C with 60 °C < boiling point =< 85 °C)	3	FC	I	3, 8, N1, N2, N3, CMR, F or S	95.0	PP, EP, EX, TOX, A	22, 23, 27, 302, 304
2927	TOXIC LIQUID, CORROSIVE, ORGANIC, N.O.S. 60 °C < boiling point =< 85 °C	6.1	TC1	I	6.1, 8, N1, N2, N3, CMR, F or S	95.0	PP, EP, TOX, A	22, 23, 27, 302, 304
2927	TOXIC LIQUID, CORROSIVE, ORGANIC, N.O.S. 85 °C < boiling point =< 115 °C	6.1	TC1	I	6.1, 8, N1, N2, N3, CMR, F or S	95.0	PP, EP, TOX, A	22, 27, 302, 304
2927	TOXIC LIQUID, CORROSIVE, ORGANIC, N.O.S. boiling point > 115 °C	6.1	TC1	I	6.1, 8, N1, N2, N3, CMR, F or S	95.0	PP, EP, TOX, A	22, 27, 302, 304
2927	TOXIC LIQUID, CORROSIVE, ORGANIC, N.O.S. 60 °C < boiling point =< 85 °C	6.1	TC1	II	6.1, 8, N1, N2, N3, CMR, F or S	95.0	PP, EP, TOX, A	22, 23, 27, 302, 304
2927	TOXIC LIQUID, CORROSIVE, ORGANIC, N.O.S. 85 °C < boiling point =< 115 °C	6.1	TC1	II	6.1, 8, N1, N2, N3, CMR, F or S	95.0	PP, EP, TOX, A	22, 27, 302, 304
2927	TOXIC LIQUID, CORROSIVE, ORGANIC, N.O.S. boiling point > 115 °C	6.1	TC1	II	6.1, 8, N1, N2, N3, CMR, F or S	95.0	PP, EP, TOX, A	22, 27, 302, 304
2929	TOXIC LIQUID, FLAMMABLE, ORGANIC, N.O.S. (Flash point < 23°C with 60 °C < boiling point =< 85 °C)	6.1	TF1	I	3, 6.1, N1, N2, N3, CMR, F or S	95.0	PP, EP, EX, TOX, A	22, 23, 27, 302, 304

UN	Description	Class	Classification code	Packing group	Dangers	%	Equipment	Remarks
2929	TOXIC LIQUID, FLAMMABLE, ORGANIC, N.O.S. (Flash point < 23°C with boiling point > 115°C)	6.1	TF1	I	3, 6.1, N1, N2, N3, CMR, F or S	95.0	PP, EP, EX, TOX, A	22, 27, 302, 304
2929	TOXIC LIQUID, FLAMMABLE, ORGANIC, N.O.S. (Flash point < 23°C with 60 °C < boiling point =< 85 °C)	6.1	TF1	II	3, 6.1, N1, N2, N3, CMR, F or S	95.0	PP, EP, EX, TOX, A	22, 23, 27, 302, 304
2929	TOXIC LIQUID, FLAMMABLE, ORGANIC, N.O.S. (Flash point < 23°C with 85 °C < boiling point =< 115 °C)	6.1	TF1	II	3, 6.1, N1, N2, N3, CMR, F or S	95.0	PP, EP, EX, TOX, A	22, 27, 302, 304
2929	TOXIC LIQUID, FLAMMABLE, ORGANIC, N.O.S. (Flash point < 23°C with boiling point > 115°C)	6.1	TF1	II	3, 6.1, N1, N2, N3, CMR, F or S	95.0	PP, EP, EX, TOX, A	22, 27, 302, 304
2929	TOXIC LIQUID, FLAMMABLE, ORGANIC, N.O.S. (Flash point < 23°C with 85 °C < boiling point =< 115 °C)	6.1	TF1	I	3, 6.1, N1, N2, N3, CMR, F or S	95.0	PP, EP, EX, TOX, A	22, 27, 302, 304
2966	THIOGLYCOL	6.1	T1	II	6.1	95.0	PP, EP, TOX, A	
3077	ENVIRONMENTALLY HAZARDOUS SUBSTANCE, SOLID, N.O.S., MOLTEN, (ALKYLAMINE (C12 to C18))	9	M7	III	9, F	95.0	PP	7, 17, 302, 304
3079	METHACRYLONITRILE, STABILIZED	6.1	TF1	I	3, 6.1, unst., N3	95.0	PP, EP, EX, TOX, A	3, 5, 301, 303
3082	ENVIRONMENTALLY HAZARDOUS SUBSTANCE, LIQUID, N.O.S.	9	M6	III	9 + (N1, N2, CMR, F or S)	97.0	PP, EP, TOX, A	22, 27, 302, 304
3082	ENVIRONMENTALLY HAZARDOUS SUBSTANCE, LIQUID, N.O.S. (BILGE WATER FREE OF SLUDGE)	9	M6	III	9, N2, F	97.0	PP	302, 304
3082	ENVIRONMENTALLY HAZARDOUS SUBSTANCE; LIQUID, N.O.S. (HEAVY HEATING OIL)	9	M6	III	9, CMR + (N1, N2, F or S)	97.0	PP	302, 304
3082	ENVIRONMENTALLY HAZARDOUS SUBSTANCE, LIQUID, N.O.S. (BILGE WATER CONTAINS SLUDGE)	9	M6	III	9, N1, CMR	97.0	PP, EP, TOX, A	45, 302, 304
3082	ENVIRONMENTALLY HAZARDOUS SUBSTANCE, LIQUID, N.O.S. (OIL SLUDGE)	9	M6	III	9, N1, CMR	97.0	PP, EP, TOX, A	45, 302, 304
3092	1-METHOXY-2-PROPANOL	3	F1	III	3	97.0	PP, EX, A	
3145	ALKYLPHENOLS, LIQUID, N.O.S. (including C2-C12 homologues)	8	C3	II	8, N3	97.0	PP, EP	27, 34
3145	ALKYLPHENOLS, LIQUID, N.O.S. (including C2-C12 homologues)	8	C3	III	8, N3	97.0	PP, EP	27, 34
3175	SOLIDS CONTAINING FLAMMABLE LIQUID, N.O.S., MOLTEN, having a flash-point up to 60°C (2-PROPANOL and DIALKYL-(C12 TO C18)-DIMETHYLAMMONIUM CHLORIDE)	4.1	F1	II	4.1	95.0	PP, EX, A	7, 17, 302, 304

UN	Description	Class	Classification code	Packing group	Dangers	%	Equipment	Remarks
3256	ELEVATED TEMPERATURE LIQUID, FLAMMABLE, N.O.S. with flash-point above 60°C, at or above its flash-point. (Maximum transport temperature: T ≤ 80°C)	3	F2	III	3 + (N1, N2, N3, CMR, F or S)	95.0	PP, EP, EX, TOX, A	7, 17, 27, 302, 304
3256	ELEVATED TEMPERATURE LIQUID, FLAMMABLE, N.O.S. with flash-point above 61°C at or above its flash-point (CARBON BLACK REEDSTOCK)(PYROLYSIS OIL)	3	F2	III	3, F	95.0	PP, EX, A	7, 17, 302
3256	ELEVATED TEMPERATURE LIQUID, FLAMMABLE, N.O.S. with flash-point above 61°C at or above its flash-point (PYROLYSIS OIL A)	3	F2	III	3, F	95.0	PP, EX, A	7, 17, 302
3256	ELEVATED TEMPERATURE LIQUID, FLAMMABLE, N.O.S. with flash-point above 61 °C at or above its flash-point (RESIDUAL OIL)	3	F2	III	3, F	95.0	PP, EX, A	7, 17, 302
3256	ELEVATED TEMPERATURE LIQUID, FLAMMABLE, N.O.S. with flash-point above 61°C at or above its flash-point (MIXTURE OF CRUDE NAPHTHALINE)	3	F2	III	3, F	95.0	PP, EX, A	7, 17, 302
3256	ELEVATED TEMPERATURE LIQUID, FLAMMABLE, N.O.S. with flash-point above 61°C at or above its flash-point (CREOSOTE OIL)	3	F2	III	3, N1, F	95.0	PP, EX, A	7, 17, 302
3259	AMINES, SOLID, CORROSIVE, N.O.S. (MONOALKYL-(C12 TO C18)-AMINE ACETATE, MOLTEN	8	C8	III	8	95.0	PP, EP	7, 17, 34, 302, 304
3264	CORROSIVE LIQUID, ACIDIC, INORGANIC, N.O.S.(Melting point > 0°C. transported at elevated temperatures.	8	C1	III	8 + (N1, N2, N3, CMR, F or S)	97.0	PP, EP, TOX, A	22, 27, 34, 302, 304
3264	CORROSIVE LIQUID, ACIDIC, INORGANIC, N.O.S. (AQUEOUS SOLUTION OF PHOSPHORIC ACID and CITRIC ACID)	8	C1	I	8	97.0	PP, EP	34, 302, 304
3264	CORROSIVE LIQUID, ACIDIC, INORGANIC, N.O.S. (AQUEOUS SOLUTION OF PHOSPHORIC ACID and CITRIC ACID)	8	C1	II	8	97.0	PP, EP	34, 302, 304
3264	CORROSIVE LIQUID, ACIDIC, INORGANIC, N.O.S. (AQUEOUS SOLUTION OF PHOSPHORIC ACID and CITRIC ACID)	8	C1	III	8	97.0	PP, EP	34, 302, 304
3264	CORROSIVE LIQUID, ACIDIC, INORGANIC, N.O.S.(with a degree of corrosiveness to steel or aluminium of 6.25 mm/year)	8	C1	III	8 + (N1, N2, N3, CMR, F or S)	97.0	PP, EP, TOX, A	22, 27, 34, 302, 304

UN	Description	Class	Classification code	Packing group	Dangers	%	Equipment	Remarks
3264	CORROSIVE LIQUID, ACIDIC, INORGANIC, N.O.S.(vP50 >= 6 kPa)	8	C1	III	8 + (N1, N2, N3, CMR, F or S)	97.0	PP, EP, TOX, A	22, 27, 34, 302, 304
3264	CORROSIVE LIQUID, ACIDIC, INORGANIC, N.O.S.(vP50 <= 12.5 kPa)	8	C1	I	8 + (N1, N2, N3, CMR, F or S)	97.0	PP, EP, TOX, A	22, 27, 34, 302, 304
3264	CORROSIVE LIQUID, ACIDIC, INORGANIC, N.O.S.(vP50 <= 12.5 kPa)	8	C1	II	8 + (N1, N2, N3, CMR, F or S)	97.0	PP, EP, TOX, A	22, 27, 34, 302, 304
3264	CORROSIVE LIQUID, ACIDIC, INORGANIC, N.O.S.(vP50 > 12.5 kPa)	8	C1	II	8 + (N1, N2, N3, CMR, F or S)	97.0	PP, EP, TOX, A	22, 27, 34, 302, 304
3264	CORROSIVE LIQUID, ACIDIC, INORGANIC, N.O.S.(vP50 > 12.5 kPa)	8	C1	I	8 + (N1, N2, N3, CMR, F or S)	97.0	PP, EP, TOX, A	22, 27, 34, 302, 304
3265	CORROSIVE LIQUID, ACIDIC, ORGANIC, N.O.S.(vP50 <= 12.5 kPa)	8	C3	I	8 + (N1, N2, N3, CMR, F or S)	97.0	PP, EP, TOX, A	22, 27, 34, 302, 304
3265	CORROSIVE LIQUID, ACIDIC, ORGANIC, N.O.S.(vP50 > 12.5 kPa)	8	C3	II	8 + (N1, N2, N3, CMR, F or S)	97.0	PP, EP, TOX, A	22, 27, 34, 302, 304
3265	CORROSIVE LIQUID, ACIDIC, ORGANIC, N.O.S.(Melting point > 0°C. transported at elevated temperatures)	8	C3	III	8 + (N1, N2, N3, CMR, F or S)	97.0	PP, EP, TOX, A	22, 27, 34, 302, 304
3265	CORROSIVE LIQUID, ACIDIC, ORGANIC, N.O.S.(with a degree of corrosiveness to steel or aluminium >= 6.25 mm/year)	8	C3	III	8 + (N1, N2, N3, CMR, F or S)	97.0	PP, EP, TOX, A	22, 27, 34, 302, 304
3265	CORROSIVE LIQUID, ACIDIC, ORGANIC, N.O.S.(vP50 >= 6 kPa)	8	C3	III	8 + (N1, N2, N3, CMR, F or S)	97.0	PP, EP, TOX, A	22, 27, 34, 302, 304
3265	CORROSIVE LIQUID, ACIDIC, ORGANIC, N.O.S.(vP50 > 12.5 kPa)	8	C3	I	8 + (N1, N2, N3, CMR, F or S)	97.0	PP, EP, TOX, A	22, 27, 34, 302, 304
3265	CORROSIVE LIQUID, ACIDIC, ORGANIC, N.O.S.(vP50 <= 12.5 kPa)	8	C3	II	8 + (N1, N2, N3, CMR, F or S)	97.0	PP, EP, TOX, A	22, 27, 34, 302, 304
3266	CORROSIVE LIQUID, BASIC, INORGANIC, N.O.S.(vP50 <= 12,5 kPa)	8	C5	I	8 + (N1, N2, N3, CMR, F or S)	97.0	PP, EP, TOX, A	22, 27, 34, 302, 304
3266	CORROSIVE LIQUID, BASIC, INORGANIC, N.O.S.(vP50 > 12,5 kPa)	8	C5	II	8 + (N1, N2, N3, CMR, F or S)	97.0	PP, EP, TOX, A	27, 34, 302, 304
3266	CORROSIVE LIQUID, BASIC, INORGANIC, N.O.S.(vP50 > 12,5 kPa)	8	C5	I	8 + (N1, N2, N3, CMR, F or S)	97.0	PP, EP, TOX, A	22, 27, 34, 302, 304

UN	Description	Class	Classification code	Packing group	Dangers	%	Equipment	Remarks
3266	CORROSIVE LIQUID, BASIC, INORGANIC, N.O.S.(vP50 <= 12,5 kPa)	8	C5	II	8 + (N1, N2, N3, CMR, F or S)	97.0	PP, EP, TOX, A	22, 27, 34, 302, 304
3266	CORROSIVE LIQUID, BASIC, INORGANIC, N.O.S.(vP50 >= 6 kPa)	8	C5	III	8 + (N1, N2, N3, CMR, F or S)	97.0	PP, EP, TOX, A	22, 27, 34, 302, 304
3267	CORROSIVE LIQUID, BASIC, ORGANIC, N.O.S.(vP50 > 12,5 kPa)	8	C7	I	8 + (N1, N2, N3, CMR, F or S)	97.0	PP, EP, TOX, A	22, 27, 34, 302, 304
3267	CORROSIVE LIQUID, BASIC, ORGANIC, N.O.S.(vP50 <= 12,5 kPa)	8	C7	II	8 + (N1, N2, N3, CMR, F or S)	97.0	PP, EP, TOX, A	22, 27, 34, 302, 304
3267	CORROSIVE LIQUID, BASIC, ORGANIC, N.O.S.(vP50 > 12,5 kPa)	8	C7	II	8 + (N1, N2, N3, CMR, F or S)	97.0	PP, EP, TOX, A	22, 27, 34, 302, 304
3267	CORROSIVE LIQUID, BASIC, ORGANIC, N.O.S.(vP50 <= 12,5 kPa)	8	C7	I	8 + (N1, N2, N3, CMR, F or S)	97.0	PP, EP, TOX, A	22, 27, 34, 302, 304
3267	CORROSIVE LIQUID, BASIC, ORGANIC, N.O.S.(vP50 >= 6 kPa)	8	C7	III	8 + (N1, N2, N3, F or S, CMR)	97.0	PP, EP, TOX, A	22, 27, 34, 302, 304
3271	ETHER, N.O.S.(Flash point < 23°C with vP50<110 kPa)	3	F1	II	3 + (N1, N2, N3, CMR, F or S)	97.0	PP, EP, EX, TOX, A	14, 22, 27, 302
3271	ETHERS, N.O.S. (tert-AMYL METHYL ETHER)	3	F1	II	3, N1	95.0	PP, EP, EX, TOX, A	302
3271	ETHERS, N.O.S.(Flash point >= 23°C but <= 60°C)	3	F1	III	3 + (N1, N2, N3, CMR, F or S)	97.0	PP, EP, EX, TOX, A	14, 22, 27, 302
3271	ETHER, N.O.S.(Flash point < 23°C with 110 kPa<=vP50<150 kPa)	3	F1	II	8 + (N1, N2, N3, CMR, F or S)	97.0	PP, EP, EX, TOX, A	14, 22, 27, 302
3271	ETHER, N.O.S.(Flash point < 23°C with 110 kPa<=vP50<175 kPa)	3	F1	II	3 + (N1, N2, N3, CMR, F or S)	97.0	PP, EP, EX, TOX, A	14, 22, 27, 302
3272	ESTERS, N.O.S.(Flash point >= 23°C but <= 60 °C)	3	F1	III	3 + (N1, N2, N3, CMR, F or S)	97.0	PP, EP, EX, TOX, A	14, 22, 27, 302
3272	ESTERS, N.O.S.(Flash point < 23°C with 110 kPa<=vP50<175 kPa)	3	F1	II	3 + (N1, N2, N3, CMR, F or S)	97.0	PP, EP, EX, TOX, A	14, 22, 27, 302
3272	ESTERS, N.O.S.(Flash point < 23°C with 110 kPa<=vP50<150 kPa)	3	F1	II	3 + (N1, N2, N3, CMR, F or S)	97.0	PP, EP, EX, TOX, A	14, 22, 27, 302

UN	Description	Class	Classification code	Packing group	Dangers	%	Equipment	Remarks
3272	ESTERS, N.O.S.(Flash point < 23°C with vP50<110 kPa)	3	F1	II	3 + (N1, N2, N3, CMR, F or S)	97.0	PP, EP, EX, TOX, A	14, 22, 27, 302
3276	NITRILES, TOXIC, LIQUID, N.O.S. (2-METHYLGLUTARONITRILE)	6.1	T1	II	6.1	97.0	A	
3286	FLAMMABLE LIQUID, TOXIC, CORROSIVE, N.O.S. (Flash point < 23°C with 60 °C < boiling point =< 85 °C)	3	FTC	II	3, 6.1, 8 + (N1, N2, N3, CMR, F or S)	95.0	PP, EP, EX, TOX, A	22, 23, 27, 302, 304
3286	FLAMMABLE LIQUID, TOXIC, CORROSIVE, N.O.S. (Flash point < 23°C with 85 °C < boiling point =< 115 °C)	3	FTC	II	3, 6.1, 8 + (N1, N2, N3, CMR, F or S)	95.0	PP, EP, EX, TOX, A	22, 27, 302, 304
3286	FLAMMABLE LIQUID, TOXIC, CORROSIVE, N.O.S. (Flash point < 23°C with boiling point > 115°C)	3	FTC	II	3, 6.1, 8 + (N1, N2, N3, CMR, F or S)	95.0	PP, EP, EX, TOX, A	22, 27, 302, 304
3286	FLAMMABLE LIQUID, TOXIC, CORROSIVE, N.O.S. (Flash point < 23°C with 60 °C < boiling point =< 85 °C)	3	FTC	I	3, 6.1, 8 + (N1, N2, N3, CMR, F or S)	95.0	PP, EP, EX, TOX, A	22, 23, 27, 302, 304
3286	FLAMMABLE LIQUID, TOXIC, CORROSIVE, N.O.S. (Flash point < 23°C with 85 °C < boiling point =< 115 °C)	3	FTC	I	3, 6.1, 8 + (N1, N2, N3, CMR, F or S)	95.0	PP, EP, EX, TOX	22, 27, 302, 304
3286	FLAMMABLE LIQUID, TOXIC, CORROSIVE, N.O.S. (Flash point < 23°C with boiling point > 115°C)	3	FTC	I	3, 6.1, 8 + (N1, N2, N3, CMR, F or S)	95.0	PP, EP, EX, TOX	22, 27, 302, 304
3287	TOXIC LIQUID, INORGANIC, N.O.S. 60 °C < boiling point =< 85 °C	6.1	T4	I	6.1 + (N1, N2, N3, CMR, F or S)	95.0	PP, EP, TOX, A	22, 23, 302, 304
3287	TOXIC LIQUID, INORGANIC, N.O.S. 85 °C < boiling point =< 115 °C	6.1	T4	I	6.1 + (N1, N2, N3, CMR, F or S)	95.0	PP, EP, TOX, A	22, 27, 302, 304
3287	TOXIC LIQUID, INORGANIC, N.O.S. boiling point > 115 °C	6.1	T4	I	6.1 + (N1, N2, N3, CMR, F or S)	95.0	PP, EP, TOX, A	22, 27, 302, 304
3287	TOXIC LIQUID, INORGANIC, N.O.S. 60 °C < boiling point =< 85 °C	6.1	T4	II	6.1 + (N1, N2, N3, CMR, F or S)	95.0	PP, EP, TOX, A	22, 23, 27, 302, 304
3287	TOXIC LIQUID, INORGANIC, N.O.S. 85 °C < boiling point =< 115 °C	6.1	T4	II	6.1 + (N1, N2, N3, CMR, F or S)	95.0	PP, EP, TOX, A	22, 27, 302, 304
3287	TOXIC LIQUID, INORGANIC, N.O.S. boiling point > 115 °C	6.1	T4	II	6.1 + (N1, N2, N3, CMR, F or S)	95.0	PP, EP, TOX, A	22, 27, 302, 304
3287	TOXIC LIQUID, INORGANIC, N.O.S. 60 °C < boiling point =< 85 °C	6.1	T4	III	6.1 + (N1, N2, N3, CMR, F or S)	95.0	PP, EP, TOX, A	22, 23, 27, 302, 304

UN	Description	Class	Classification code	Packing group	Dangers	%	Equipment	Remarks
3287	TOXIC LIQUID, INORGANIC, N.O.S. 85 °C < boiling point =< 115 °C	6.1	T4	III	6.1 + (N1, N2, N3, CMR, F or S)	95.0	PP, EP, TOX, A	22, 27, 302, 304
3287	TOXIC LIQUID, INORGANIC, N.O.S. boiling point > 115 °C	6.1	T4	III	6.1 + (N1, N2, N3, CMR, F or S)	95.0	PP, EP, TOX, A	22, 27, 302, 304
3287	TOXIC LIQUID, INORGANIC, N.O.S. (SODIUM DICHROMATE SOLUTION)	6.1	T4	III	6.1, CMR	95.0	PP, EP, TOX, A	302
3289	TOXIC LIQUID, CORROSIVE, INORGANIC, N.O.S. boiling point > 115 °C	6.1	TC3	I	6.1, 8 + (N1, N2, N3, CMR, F or S)	95.0	PP, EP, TOX, A	22, 27, 302, 304
3289	TOXIC LIQUID, CORROSIVE, INORGANIC, N.O.S. boiling point > 115 °C	6.1	TC3	II	6.1, 8 + (N1, N2, N3, CMR, F or S)	95.0	PP, EP, TOX, A	22, 27, 302, 304
3295	HYDROCARBONS, LIQUID, N.O.S.(Flash point >= 23°C but <= 60 °C)	3	F1	III	3 + (N1, N2, N3, CMR, F)	97.0	PP, EP, EX, TOX, A	14, 22, 27, 301
3295	HYDROCARBONS, LIQUID, N.O.S. (1-OCTEN)	3	F1	II	3, N2, F	97.0	PP, EX, A	14, 301
3295	HYDROCARBONS, LIQUID, N.O.S. (POLYCYCLIC AROMATIC HYDROCARBONS MIXTURE)	3	F1	III	3, CMR, F	97.0	PP, EP, EX, TOX, A	14, 301
3295	HYDROCARBONS, LIQUID, N.O.S. WITH MORE THAN 10% BENZENE 60 °C < INITIAL BOILING POINT =< 85 °C	3	F1	II	3, N1, N2, N3, CMR, F	95.0	PP, EP, EX, TOX, A	23, 38, 301
3295	HYDROCARBONS, LIQUID, N.O.S. WITH MORE THAN 10% BENZENE 85 °C < INITIAL BOILING POINT =< 115 °C	3	F1	II	3, N1, N2, N3, CMR, F	95.0	PP, EP, EX, TOX, A	301
3295	HYDROCARBONS, LIQUID, N.O.S. WITH MORE THAN 10% BENZENE INITIAL BOILING POINT > 115°C	3	F1	II	3, N1, N2, N3, CMR, F	95.0	PP, EP, EX, TOX, A	301
3295	HYDROCARBONS, LIQUID, N.O.S. WITH MORE THAN 10% BENZENE 60 °C < INITIAL BOILING POINT =< 85 °C	3	F1	III	3, N1, N2, N3, CMR, F	95.0	PP, EP, EX, TOX, A	23, 38, 301
3295	HYDROCARBONS, LIQUID, N.O.S. WITH MORE THAN 10% BENZENE 85 °C < INITIAL BOILING POINT =< 115 °C	3	F1	III	3, N1, N2, N3, CMR, F	95.0	PP, EP, EX, TOX, A	301
3295	HYDROCARBONS, LIQUID, N.O.S. WITH MORE THAN 10% BENZENE INITIAL BOILING POINT > 115 °C	3	F1	III	3, N1, N2, N3, CMR, F	95.0	PP, EP, EX, TOX, A	301
3295	HYDROCARBONS, LIQUID, N.O.S. CONTAINING ISOPRENE AND PENTADIENE, STABILIZED	3	F1	I	3, unst., N2, CMR	95.0	PP, EX, A	3, 23, 301
3295	HYDROCARBONS, LIQUID, N.O.S.(Flash point < 23°C with 110 kPa<=vP50<175 kPa)	3	F1	I	3 + (N1, N2, N3, CMR, F)	97.0	PP, EP, EX, TOX, A	14, 22, 27, 301

UN	Description	Class	Classification code	Packing group	Dangers	%	Equipment	Remarks
3295	HYDROCARBONS, LIQUID, N.O.S.(Flash point < 23°C with 110 kPa<=vP50<175 kPa)	3	F1	II	3 + (N1, N2, N3, CMR, F)	97.0	PP, EP, EX, TOX, A	14, 22, 27, 301
3295	HYDROCARBONS, LIQUID, N.O.S.(Flash point < 23°C with 110 kPa<=vP50<150 kPa)	3	F1	I	3 + (N1, N2, N3, CMR, F)	97.0	PP, EP, EX, TOX, A	14, 22, 27, 301
3295	HYDROCARBONS, LIQUID, N.O.S.(Flash point < 23°C with 110 kPa<=vP50<150 kPa)	3	F1	II	3 + (N1, N2, N3, CMR, F)	97.0	PP, EP, EX, TOX, A	14, 22, 27, 301
3295	HYDROCARBONS, LIQUID, N.O.S.(Flash point < 23°C with vP50<110 kPa)	3	F1	II	3 + (N1, N2, N3, CMR, F)	97.0	PP, EP, EX, TOX, A	14, 22, 27, 301
3295	HYDROCARBONS, LIQUID, N.O.S.(Flash point < 23°C with vP50<110 kPa)	3	F1	I	3 + (N1, N2, N3, CMR, F)	97.0	PP, EP, EX, TOX, A	14, 22, 27, 301
3295	HYDROCARBONS, LIQUID, N.O.S. WITH MORE THAN 10% BENZENE (Flash point < 23°C with 60°C < BOILING POINT =< 85°C)	3	F1	I	3, N1, N2, N3, CMR	95.0	PP, EP, EX, TOX, A	22, 23, 27, 301
3295	HYDROCARBONS, LIQUID, N.O.S. WITH MORE THAN 10% BENZENE (Flash point < 23°C with 60°C < BOILING POINT =< 85°C)	3	F1	II	3, N1, N2, N3, CMR	95.0	PP, EP, EX, TOX, A	22, 23, 27, 301
3295	HYDROCARBONS, LIQUID, N.O.S. WITH MORE THAN 10% BENZENE (60°C < BOILING POINT =< 85°C)	3	F1	III	3, N1, N2, N3, CMR	95.0	PP, EP, EX, TOX, A	22, 23, 27, 301
3295	HYDROCARBONS, LIQUID, N.O.S. WITH MORE THAN 10% BENZENE (Flash point < 23°C with 85°C < BOILING POINT =< 115°C)	3	F1	I	3, N1, N2, N3, CMR	95.0	PP, EP, EX, TOX, A	22, 27, 301
3295	HYDROCARBONS, LIQUID, N.O.S. WITH MORE THAN 10% BENZENE (Flash point < 23°C with 85°C < BOILING POINT =< 115°C)	3	F1	II	3, N1, N2, N3, CMR	95.0	PP, EP, EX, TOX, A	22, 27, 301
3295	HYDROCARBONS, LIQUID, N.O.S. WITH MORE THAN 10% BENZENE (85°C < BOILING POINT =< 115°C)	3	F1	III	3, N1, N2, N3, CMR	95.0	PP, EP, EX, TOX, A	22, 27, 301
3295	HYDROCARBONS, LIQUID, N.O.S. WITH MORE THAN 10% BENZENE (Flash point < 23°C with BOILING POINT > 115°C)	3	F1	I	3, N1, N2, N3, CMR	95.0	PP, EP, EX, TOX, A	22, 27, 301
3295	HYDROCARBONS, LIQUID, N.O.S. WITH MORE THAN 10% BENZENE (Flash point < 23°C with BOILING POINT > 115°C)	3	F1	II	3, N1, N2, N3, CMR	95.0	PP, EP, EX, TOX, A	22, 27, 301
3295	HYDROCARBONS, LIQUID, N.O.S. WITH MORE THAN 10% BENZENE (BOILING POINT > 115°C)	3	F1	III	3, N1, N2, N3, CMR	95.0	PP, EP, EX, TOX	22, 27, 301

UN	Description	Class	Classification code	Packing group	Dangers	%	Equipment	Remarks
3295	HYDROCARBONS, LIQUID, N.O.S. WITH MORE THAN 10% BENZENE (According ADN 3.2.3.3 – Scheme A – Criteria for cargo tank equipment in vessels of Type C)	3	F1	I	3, N1, N2, N3, CMR	95.0	PP, EP, EX, TOX, A	22, 23, 27, 98, 301
3295	HYDROCARBONS, LIQUID, N.O.S. WITH MORE THAN 10% BENZENE (According ADN 3.2.3.3 – Scheme A – Criteria for cargo tank equipment in vessels of Type C)	3	F1	II	3, N1, N2, N3, CMR	95.0	PP, EP, EX, TOX, A	22, 23, 27, 98, 301
3412	FORMIC ACID with not less 10% but not more than 85% acid by mass	8	C3	II	8, N3	97.0	PP, EP	6: +12°C, 17, 34, 301
3412	FORMIC ACID with not less than 5% but less than 10% acid by mass	8	C3	III	8	97.0	PP, EP	6: +12°C, 17, 34, 301
3426	ACRYLAMIDE, SOLUTION	6.1	T1	III	6.1	95.0	PP, EP, TOX, A	3, 5, 16, 301, 303
3429	CHLOROTOLUIDINES, LIQUID	6.1	T1	III	6.1, S	95.0	PP, EP, EX, TOX, A	6: +6 °C, 17, 301, 303
3446	NITROTOLUENES, SOLID, MOLTEN (p-NITROTOLUENE, MOLTEN)	6.1	T2	II	6.1, N2, S	95.0	PP, EP, EX, TOX, A	7, 17
3451	TOLUIDINES, SOLID, MOLTEN (p-TOLUIDINE)	6.1	T2	II	6.1, N1	95.0	PP, EP, EX, TOX, A	7, 17
3451	TOLUIDINES, SOLID, MOLTEN (p-TOLUIDINE)	6.1	T2	II	6.1, N1	95.0	PP, EP, TOX, A	7, 17, 20: + 60 °C
3455	CRESOLS, SOLID, MOLTEN	6.1	TC2	II	6.1, 8, N3	95.0	PP, EP, EX, TOX, A	7, 17, 302
3455	CRESOLS, SOLID, MOLTEN	6.1	TC2	II	6.1, 8, N3	95.0	PP, EP, TOX, A	7, 17, 20: +66 °C, 302
3463	PROPIONIC ACID with not less than 90% acid by mass	8	CF1	II	3, 8, N3	97.0	PP, EP, EX, A	34, 301
3475	ETHANOL AND GASOLINE MIXTURE or ETHANOL AND MOTOR SPIRIT MIXTURE or ETHANOL AND PETROL MIXTURE, with more than 10% but not more than 90% ethanol	3	F1	II	3, N2, CMR, F	97.0	PP, EP, EX, TOX, A	301, 303
3475	ETHANOL AND GASOLINE MIXTURE or ETHANOL AND MOTOR SPIRIT MIXTURE or ETHANOL AND PETROL MIXTURE, with more than 90% ethanol	3	F1	II	3, N2, CMR, F	97.0	PP, EP, EX, TOX, A	301, 303
3494	PETROLEUM SOUR CRUDE OIL, FLAMMABLE, TOXIC (Flash point < 23°C with boiling point > 115°C)	3	TF1	I	3, 6.1 + (N1, N2, N3, CMR, F)	95.0	PP, EP, EX, TOX, A	14, 22, 302, 304

UN	Description	Class	Classification code	Packing group	Dangers	%	Equipment	Remarks
3494	PETROLEUM SOUR CRUDE OIL, FLAMMABLE, TOXIC (Flash point < 23°C with 60 °C < boiling point =< 85 °C)	3	TF1	I	3, 6.1 + (N1, N2, N3, CMR, F)	95.0	PP, EP, EX, TOX, A	14, 22, 23, 302, 304
3494	PETROLEUM SOUR CRUDE OIL, FLAMMABLE, TOXIC (Flash point < 23°C with 85 °C < boiling point =< 115 °C)	3	TF1	I	3, 6.1 + (N1, N2, N3, F)	95.0	PP, EP, EX, TOX, A	14, 22, 302, 304
3494	PETROLEUM SOUR CRUDE OIL, FLAMMABLE, TOXIC (Flash point < 23°C with 60 °C < boiling point =< 85 °C)	3	TF1	II	3, 6.1 + (N1, N2, N3, CMR, F)	95.0	PP, EP, EX, TOX, A	14, 22, 23, 302, 304
3494	PETROLEUM SOUR CRUDE OIL, FLAMMABLE, TOXIC (Flash point < 23°C with 85 °C < boiling point =< 115 °C)	3	TF1	II	3, 6.1 + (N1, N2, N3, CMR, F)	95.0	PP, EP, EX, TOX, A	14, 22, 302, 304
3494	PETROLEUM SOUR CRUDE OIL, FLAMMABLE, TOXIC (Flash point < 23°C with boiling point > 115°C)	3	TF1	II	3, 6.1 + (N1, N2, N3, CMR, F)	95.0	PP, EP, EX, TOX, A	14, 22, 302, 304
3494	PETROLEUM SOUR CRUDE OIL, FLAMMABLE, TOXIC (boiling point > 115°C)	3	TF1	III	3, 6.1 + (N1, N2, N3, CMR, F)	95.0	PP, EP, EX, TOX, A	14, 22, 302, 304
3494	PETROLEUM SOUR CRUDE OIL, FLAMMABLE, TOXIC (0 °C < boiling point =< 85 °C)	3	TF1	III	3, 6.1 + (N1, N2, N3, CMR, F)	95.0	PP, EP, EX, TOX, A	14, 22, 23, 302, 304
3494	PETROLEUM SOUR CRUDE OIL, FLAMMABLE, TOXIC (85 °C < boiling point =< 115 °C)	3	TF1	III	3, 6.1 + (N1, N2, N3, CMR, F)	95.0	PP, EP, EX, TOX, A	14, 22, 302, 304
9001	SUBSTANCE WITH A FLASH-POINT ABOVE 60 °C HEATED within a range of 15 K below the flashpoint	3	F4		3 + (N1, N2, N3, CMR, F or S)	97.0	PP, EP, EX, TOX, A	22, 27, 302, 304
9003	SUBSTANCES WITH A FLASH-POINT ABOVE 60°C BUT NOT MORE THAN 100°C or SUBSTANCES WHERE 60°C <°flash-point =< 100°C, which cannot be classified in other classes (N.O.S.)	9	M12		9 + (N1, N2, N3, CMR, F or S)	97.0	PP	22, 27, 302, 304
9003	SUBSTANCES WITH A FLASH-POINT ABOVE 60°C BUT NOT MORE THAN 100°C or SUBSTANCES WHERE 61°C <°flash-point =< 100°C, which cannot be classified in other classes (ETHYLENE GLYCOL MONOBUTYL ETHER)	9	M12		9, N3, F	97.0	PP	302, 304
9003	SUBSTANCES WITH A FLASH-POINT ABOVE 60°C BUT NOT MORE THAN 100°C or SUBSTANCES WHERE 61°C <°flash-point =< 100°C, which cannot be classified in other classes (2-ETHYLHEXYLACRYLATE)	9	M12		9, N3, F	97.0	PP	3, 5, 16, 302, 304
9004	DIPHENYLMETHANE-4,4'-DIISOCYANATE	9	M12		9, S	95.0	PP	7, 8, 17, 19, 302, 304

UN	Description	Class	Classification code	Packing group	Dangers	%	Equipment	Remarks
9005	ENVIRONMENTALLY HAZARDOUS SUBSTANCE, SOLID, N.O.S, MOLTEN (Maximum transport temperature: T <= 80°C)	9	M12		9 + (N2, N3, CMR, F or S)	95.0	PP, EP, TOX, A	7, 22, 27, 200, 302, 304
9006	ENVIRONMENTALLY HAZARDOUS SUBSTANCE, LIQUID, N.O.S.(Corrosive, Non-flammable substances)	9			9 + (N2, N3, CMR, F or S)	97.0	PP, EP, EX, A	22, 27, 200, 302, 304
9006	ENVIRONMENTALLY HAZARDOUS SUBSTANCE, LIQUID, N.O.S.WITH A FLASH-POINT ABOVE 60°C BUT NOT MORE THAN 100°C	9			9 + (N2, N3, CMR, F or S)	97.0	PP, EP, TOX, A	22, 27, 200, 302, 304
9006	ENVIRONMENTALLY HAZARDOUS SUBSTANCE, LIQUID, N.O.S. CMR	9			9 + (N2, N3, CMR, F or S)	97.0	PP, EP, TOX, A	22, 27, 200, 302, 304

Remarks

The following remarks are referened in the column "Remarks" in this list of dangerous goods.

The numbering of the remarks, with numbers below 100, comply with the numbering of the remarks in column 20 of the Product list in Part 3 Table C of the ADN. Only the applicable note(s) to the substances included on the list have been included on the next page(s).

The numbering of the remarks greater or equal to 100 provides details of the material compatibility of the used tank materials in relation to the cargoes to be carried. For this list the recommendations of the "Bundesanstalt für Materialforschung und prüfung" (BAM) in Berlin have been used. The recommendations are based on a maximum average temperature of the tank bulkhead of 30° Celsius. Short periods (during loading) a maximum temperature of 50° Celsius are allowed. The requirements are based on substances which are technically clean and in the conditions normally available. For mixtures, intermediates and waste products the material compatibility is to be specially considered. Substances which are an unstable mixture with water may not contain water.

The responsibility with regard to the suitability of the containment system for the cargo to be carried rests with the owner and/or the master of the ship. The contents of the column "notes" has therefore been provided for information only. Lloyd's Register has no responsibility with regard to the correctness of the provided data with regard to the material compatibility. Due to the nature of some products, amongst others the so-called n.o.s. (not otherwise specified) positions, no data is available with regard to material compatibility and accordingly no relevant information can be provided for those substances.

Remarks on materials & coatings

n/a

No.	Remark
2	Before loading, air shall be removed and subsequently kept away to a sufficient extent from the cargo tanks and the accessory cargo piping by the means of inert gas (see also 7.2.4.18).
3	<p>Arrangements shall be made to ensure that the cargo is sufficiently stabilized in order to prevent a reaction at any time during carriage. The transport document shall contain the following additional particulars:</p> <p>a) Name and amount of inhibitor added;</p> <p>b) Date on which inhibitor was added and expected duration of effectiveness under normal conditions;</p> <p>c) Any temperature limits having an effect on the inhibitor.</p> <p>When stabilization is ensured solely by blanketing with an inert gas it is sufficient to mention the name of the inert gas used in the transport document.</p> <p>When stabilization is ensured by another measurement, e.g. the special purity of the substance, this measurement shall be mentioned in the transport document.</p>
4	The substance shall not be allowed to solidify; the transport temperature shall be maintained above the melting point. In instances where cargo heating installations are required, they must be so designed that polymerisation through heating is not possible in any part of the cargo tank. Where the temperature of steam-heated coils could give rise to overheating, lower-temperature indirect heating systems shall be provided.
5	<p>This substance is liable to clog the venting piping and its fittings or the fittings of cargo tanks. Careful surveillance should be ensured.</p> <p>If a closed-type tank vessel cargo tank is required for the carriage of this substance and explosion protection is necessary or the substance for which explosion protection is necessary is carried in a closed cargo tank, the cargo tank shall conform to 9.3.2.22.4 or 9.3.3.22.4 or the venting piping shall conform to 9.3.2.22.5 (a) or 9.3.2.22.5 (b) or to 9.3.3.22.5 (a) or 9.3.3.22.5 (b).</p> <p>This requirement does not apply when the cargo tanks and the corresponding piping are inerted in accordance with 7.2.4.18.</p>
6	<p>When external temperatures are below or equal to that indicated in column (20), the substance may only be carried in tank vessels equipped with a possibility of heating the cargo.</p> <p>In addition, in the event of carriage in a closed cargo tank, the venting piping, the safety valves and the flame arresters shall be heatable.</p> <p>The temperature of the venting piping, safety valves and flame arresters shall be kept at least above the melting point of the substance.</p>
7	<p>If a closed cargo tank is required to carry this substance or if the substance is carried in a closed cargo tank, the venting piping, the safety valves and the flame arresters shall be heatable.</p> <p>The temperature of the venting piping, safety valves and flame arresters shall be kept at least above the melting point of the substance.</p>
8	Double-hull spaces, double bottoms and heating coils shall not contain any water.
14	<p>The following substances may not be carried in a type N vessel:</p> <ul style="list-style-type: none"> -substances with self-ignition temperatures ≤ 200 °C; -mixtures containing halogenated hydrocarbons; -mixtures containing more than 10 % benzene; -substances and mixtures carried in a stabilized state. <p>Note! This remark does not apply if the substance is carried in a tanker of Type G or Type C.</p>
15	Provision shall be made to ensure that alkaline or acidic substances such as sodium hydroxide solution or sulphuric acid do not contaminate this cargo.

No.	Remark
16	If there is a possibility of a dangerous reaction such as polymerisation, decomposition, thermal instability or evolution of gases resulting from local overheating of the cargo in either the cargo tank or associated piping system, this cargo shall be loaded and carried adequately segregated from other substances the temperature of which is sufficiently high to initiate such reaction. Heating coils inside cargo tanks carrying this substance shall be blanked off or secured by equivalent means.
17	The melting point of the cargo shall be shown in the transport documents.
19	<p>Provision shall be made to ensure that the cargo does not come into contact with water. The following additional requirements apply:</p> <p>Carriage of the cargo is not permitted in cargo tanks adjacent to slop tanks or cargo tanks containing ballast water, slops or any other cargo containing water. Pumps, piping and vent lines connected to such tanks shall be separated from similar equipment of tanks carrying these substances. Pipes from slop tanks or ballast water pipes shall not pass through cargo tanks containing this cargo unless they are encased in a tunnel.</p>
20	The maximum permitted transport temperature given in column (20) shall not be exceeded.
22	The relative density of the cargo shall be shown in the transport document.
23	The instrument for measuring the pressure of the vapour phase in the cargo tank shall activate the alarm when the internal pressure reaches 40 kPa. The water-spray system shall immediately be activated and remain in operation until the internal pressure drops to 30 kPa.
27	The requirements of 3.1.2.8.1 are applicable.
30	When these substances are carried, the hold spaces of open type N tank vessels may contain auxiliary equipment.
34	For type N carriage, the flanges and stuffing boxes of the loading and unloading hoses must be fitted with a protection device to protect against splashing.
38	For an initial boiling point above 60° C and under or equal to 85° C as determined in accordance with ASTM D 86-01, the applicable conditions of transport are identical to those stipulated for an initial boiling point under or equal to 60° C.
41	n-BUTYLBENZENE is assigned to the entry UN No. 2709 BUTYLBENZENES (n-BUTYLBENZENE).
45	When this substance is received from seagoing vessels as waste related to the operation of the vessel, appropriate measures shall be taken on board the vessels to avoid or minimize, to the extent possible, the exposure of personnel on board to gas/air mixtures escaping from the cargo tanks of the receiving vessel during loading and to ensure the protection of personnel on board during such activities. Appropriate personal protective equipment shall be made available to the employees in question and shall be worn for the duration of the increased exposure.
98	Only allowed to be carried with a confirmation that the cargo tank internal pressure at a liquid temperature of 30 °C and gaseous phase temperature of 37.8 °C is less than or equal 50 kPa
200	The applicable requirements for this ship and her outfitting are for the carriage of this substance, depending on the properties of this substance, are to be determined using the flowchart in part 3.2.3 of the ADN regulations. Additional requirements may be applicable.
301	316 L Nr. 1.4401 CrNiMo - This material is compatible with this substance provided that the additional requirements and conditions are complied with. For more details please consult the additional information.

No.	Remark
302	316 L Nr. 1.4401 CrNiMo - For this material no particular data is available with regard to the material compatibility in respect of this substance. The loading of the tanks with this substance rests with the responsible person for loading the ship.
303	EN 1.4462 - This material is compatible with this substance provided that the additional requirements and conditions are complied with. For more details please consult the additional information.
304	EN 1.4462 - For this material no particular data is available with regard to the material compatibility in respect of this substance. The loading of the tanks with this substance rests with the responsible person for loading the ship.

Signed by:

K.L. Vinke

Principal Specialist Chemical Tankers

