



Economic and Social Council

Distr.: General
2 September 2022

Original: English

Economic Commission for Europe

Inland Transport Committee

World Forum for Harmonization of Vehicle Regulations

188th session

Geneva, 14-16 November 2022

Item 4.13.2 of the provisional agenda

1958 Agreement:

Consideration of proposals for new UN Regulations submitted by the Working Parties subsidiary to the World

Proposal for a New UN Regulation on Uniform Provisions Concerning the Approval of Motor Vehicles with Regard to their Direct Vision

Submitted by the Working Party on General Safety Provisions *

The text reproduced below was adopted by the Working Party on General Safety Provisions (GRSG) at its 123rd session (ECE/TRANS/WP.29/GRSG/102, para. 28). It is based on ECE/TRANS/WP.29/GRSG/2022/7 as amended by annex VII to the report. It is submitted to the World Forum for Harmonization of Vehicle Regulations (WP.29) and to the Administrative Committee (AC.1) for consideration at their November 2022 sessions.

* In accordance with the programme of work of the Inland Transport Committee for 2022 as outlined in proposed programme budget for 2022 (A/76/6 (part V, sect. 20) para. 20.76), the World Forum will develop, harmonize and update UN Regulations in order to enhance the performance of vehicles. The present document is submitted in conformity with that mandate.



Proposal of a new UN Regulation on Vulnerable Road Users in Front and Side Close Proximity, to read:

"UN Regulation No. XXX

Uniform Provisions Concerning the Approval of Motor Vehicles with Regard to Their Direct Vision

Contents

*Page***

Regulation

0.	Introduction	
1.	Scope	
2.	Definitions	
3.	Application for Approval	
4.	Approval	
5.	Specifications	
6.	Test Procedure	
7.	Modification of Vehicle Type and Extension of Approval	
8.	Conformity of Production	
9.	Penalties for Non-Conformity of Production	
10.	Production Definitively Discontinued	
11.	Names and Addresses of the Technical Services Responsible for Conducting Approval Tests and of Type Approval Authorities	

Annexes

1	Information Document for the Type Approval of a Vehicle with Respect to its Direct Vision	
2	Communication Concerning the Approval or Refusal or Extension or Withdrawal of Approval or Production Definitively Discontinued of a Type of Vehicle with Regard to its Direct Vision	
3	Arrangements of Approval Marks.....	
4	Assessment Volume	
5	Assigning Vehicles to Direct Vision Levels and Compliance Methods	
6	Physical Test Method	
7	Numerical Test Method.....	

** Page numbers will be added at a later stage.

0. Introduction (for information)

- 0.1. Collisions between Vulnerable Road Users (VRU) and large commercial vehicles that are undertaking low speed manoeuvres, such as turning or moving off from rest, typically occur at low driving speeds. They usually have serious consequences for VRU. In the past, the safety of VRU in these situations was increased by an improvement of the driver's indirect vision (blind spot mirrors) and by equipping trucks with side underrun protection. However, these low-speed manoeuvring collisions still happen so further improvements have been considered necessary.
- 0.2. The cause of this type of collision can be contributed to by many factors. The VRU may have been positioned in a place where they were not available to be seen by the driver through either glazed areas or mirrors. Alternatively, they may have been available to be seen during the build-up to the collision, but the driver may have detected their presence too late to avoid collision, or may have failed to detect their presence at all. This late detection, or failure to detect, could be a result of the driver failing to look, looking but failing to see, or seeing but failing to correctly judge the risk.
- 0.3. Elimination of this type of collision may consider action that mitigates many of these different causes. Other regulations have been introduced concurrently to use electronic sensing systems to detect a VRU in close proximity to the vehicle and to inform the driver of their presence via a low urgency information signal (e.g. light) and to provide a collision warning (e.g. audio-visual) when the situation becomes more critical.
- 0.4. Blind spot information systems and collision warnings will be most effective when they draw the attention of the driver to a hazard that can be seen and quickly identified as a valid threat. For many VRU collision situations with many designs of vehicle preceding this regulation, the VRU will not be directly visible through the front or side windows of the vehicle. Many will be visible in mirrors, but the evidence suggests that this is not sufficient to prevent all collisions.
- 0.5. Visibility in mirrors can be very beneficial but suffers several limitations compared with direct vision. Human vision has evolved on the basis of two main zones of vision. Foveal vision is the high-resolution area at the centre of the view that is used to see and recognise objects. Peripheral vision contains much less detail but is very sensitive to movement and uses the detection of movement to quickly draw attention and to focus foveal vision on the threat. In the context of this regulation, it is nature's own collision warning system. Images in mirrors are small and may not show sufficient motion to trigger peripheral vision. They must be deliberately and actively scanned by the driver. Mirrors allow only limited depth perception. Images from convex mirror lenses may be distorted, particularly around the edges, and blind spot mirrors may be positioned in counter-intuitive positions with unexpected orientations of the subject. For example, the driver may need to look up towards the vehicle roofline, to see an image that looks down on the top of the head of a cyclist positioned alongside the vehicle. The use of well specified camera monitor systems to replace mirrors can improve on some but not all of these aspects.

Improving direct vision has significant potential to help drivers avoid collisions by both reducing the chance that areas around the vehicle are not visible in either direct or indirect vision. It may also enhance the ability of the driver to respond quickly where VRUs are visible in indirect vision
- 0.6. Therefore, this UN Regulation asks for commercial vehicles that meet certain minimum standards of direct vision, in order to maximise the chances of a driver recognising and quickly reacting to the presence of a VRU in critical situations during low speed manoeuvring. It also seeks to maximise the effectiveness of blind spot information systems and collision warnings.
- 0.7. However, in some circumstances, it will be significantly challenging for vehicle manufacturers to provide good direct vision without compromising

other important operational characteristics, such as driver comfort and wellbeing, high power/cooling for high-capacity transport or high ground clearance for off-road operation. The evidence strongly suggests that the vast majority of potentially relevant close proximity manoeuvring collisions occur in major conurbations and very few on major inter-urban roads. As such, the Regulation has set out differing performance levels for different subcategories of vehicle, based on criteria considered highly likely to be indicative of the likelihood that they will be regularly used in urban areas and recognising certain operational limitations. The possibility that adapted requirements of some form may be required for particularly challenging vehicles remains under investigation.

- 0.8. The Regulation recognises that enabling direct vision of any part of a VRU could potentially help a driver to recognise their presence and avoid a collision. In particular, it is considered that innovations such as windows in the lower panels of doors, that help to see VRUs adjacent to the vehicle at around waist height can be beneficial. For this reason, the Regulation calls for a minimum volume of space around the vehicle to be visible rather than simply visibility of an indicator representing head height, or an area on the floor as is the case for other visibility regulations. The use of a volumetric assessment method provides more flexibility for industry to innovate in their provision of the minimum required view.
- 0.9. While the volumetric assessment method and its assessment zones is derived from the geometrical conditions and installation of devices for indirect vision, specifically mirrors of classes V and VI, of large trucks, the scope of this regulation at its “lower” end also includes vehicles of categories M₂ and N₂ that are derived from vehicles of categories M₁ and N₁. These vehicles meet or will soon have to meet Regulation No. 125, equally addressing the direct vision of the driver. To avoid duplicate regulation, these vehicles should therefore be allowed to use compliance to Regulation No. 125 to meet this Regulation. For those vehicles however not derived from M₁ or N₁, as these vehicles are usually not fitted with devices for indirect vision of classes V and VI and as the eye-point positions defined for large trucks may not be representative to these vehicles it is further proposed to include an alternative assessment method. Noting that the vehicles in this category, due to their relatively low seating positions, robustly overachieve the requirements of this regulation, and as the accident statistics for them did not highlight any increased risks associated with direct vision, it is deemed that a simplified alternative method is justified.

1. Scope

- 1.1. This Regulation applies to the approval of vehicles of categories M₂, M₃, N₂ and N₃ with regard to their Direct Vision to reduce blind spots to the greatest extent possible, considering the needs of the specific type of vehicle and the operation it is intended for.
- 1.2. The requirements of this Regulation are formulated for vehicles which are developed for right-hand or left-hand traffic. The requirements shall be applied as appropriate.

2. Definitions

For the purposes of this Regulation:

- 2.1. “*Direct Vision*” means the field of vision from the driver’s eye point that can be seen without the aid of indirect vision devices such as mirrors or cameras.
- 2.2. “*Vehicle type with regard to its Direct Vision*” means vehicles which do not differ in such essential respects as:
- (a) The manufacturer's trade name or mark;

- (b) The dimensions and shapes of the components of the vehicle structure situated in front of a vertical plane positioned 1000mm behind the driver's eye point (E2) and perpendicular to the longitudinal plane of the vehicle;
- (c) The distance in the X axis between the centre of the front axle of the vehicle and the foremost point of the vehicle;
- (d) The number, size, shape or location of transparent areas of the vehicle situated in front of a vertical plane positioned 1,000 mm behind the driver's eye point (E2) and perpendicular to the longitudinal plane of the vehicle;
- (e) The direct vision level, as defined by the table in Annex 5, that the vehicle will fall into.

2.3. "Driver's eye point" or "E-point" means a point representing the midpoint between the centre of the driver's left and right eye. Three separate eye points are defined. E2 is the forward eye point, E1 is the left-side eyepoint and E3 is the right-side eyepoint. Each point is defined using the three-dimensional reference system. E2 is defined by an offset from the accelerator heel point of 1,163.25 mm in the Z axis, and 678 mm rearward in the X axis. The position of E2 in the Y axis is on a vertical plane, parallel to the median longitudinal plane and passing through the centre of the driver's seat. Points E1 and E3 are defined by a 60° rotation, to the left and right respectively, about the P-Point.

Figure 1
Definition of E-Points

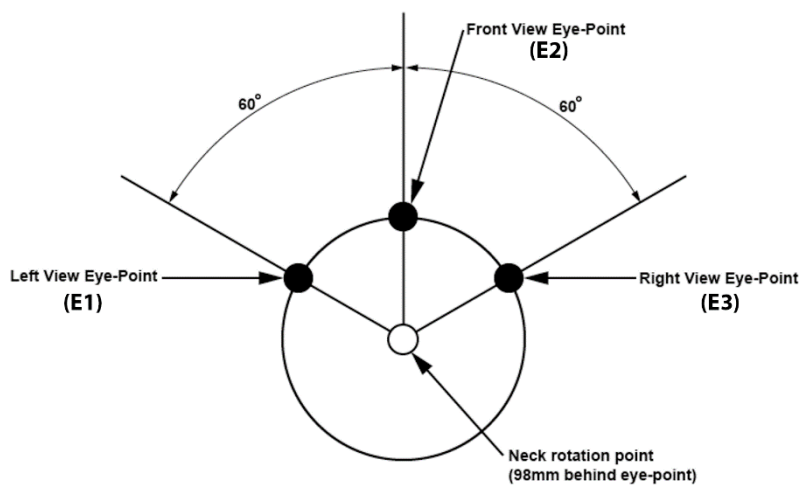

- 2.4. "Transparent area" means that area of a vehicle windscreen or other glazed surface, if fitted, that permits light transmittance measured in a direction perpendicular to the surface of not less than 70 per cent, excluding any dot printed area of opaque obscuration.
- 2.5. "Assessment volume" means the volume of space around the forward part of the vehicle where visibility of part of a vulnerable road user will be considered to contribute to the measurement of the vehicle's direct vision performance. The geometry of the assessment volume is defined in Annex 4.
- 2.6. "Vision occlusion" means any permanently fitted part of the structure of the vehicle, or of the interior of the driver's cabin, that would obstruct a sightline passing from any of the three defined E-Points to any part of the assessment volume.
- 2.7. "Sightline" means a straight line representing the driver's line of sight from an eye point either to a target point or at any particular defined angle within the three-dimensional reference system.

- 2.8. “*Direct Vision Opening Line*” means the intersection of a surface with a sight line that is positioned at a tangent to the first vision occlusion that would obstruct that sightline (e.g. A-pillar, lower edge of windscreen, steering wheel windscreen wipers, etc.). See the Figure in Annex 7 for an illustration of the process.
- 2.9. “*Total Visible Volume*” means a volume of space, contained entirely within the assessment volume, that is visible via sightlines projected from one of the E-Points through the direct vision opening lines. It is the sum of visible volumes to the nearside, the front and the offside of the vehicle.
- 2.9.1. “*Nearside Visible Volume*” means the portion of the visible volume that can be seen by a sightline projected from the point E1 for left-hand traffic or E3 for right-hand traffic, to the rear of the A-pillar on the near side of the vehicle, where the view from the driver’s seat would predominantly lie outboard of the nearside plane of the vehicle.
- 2.9.2. “*Front Visible Volume*” means the portion of the visible volume that can be seen by a sightline projected from the point E2 between the A-pillars of the vehicle where the view from the driver’s seat would predominantly lie forward of the frontal plane of the vehicle.
- 2.9.3. “*Offside Visible Volume*” means the portion of the visible volume that can be seen by a sightline projected from the point E3 for left-hand traffic or E1 for right-hand traffic, to the rear of the A-pillar on the offside of the vehicle, where the view from the driver’s seat would predominantly lie outboard of the offside plane of the vehicle.
- 2.10. “*Engine power*” means the maximum net power as defined by UN Regulation No. 85.
- 2.11. “*Sleeper cab*” means a type of cab that has a compartment behind the driver’s seat intended to be used for sleeping.
- 2.12. “*Day cab*” means a type of cab that is not a sleeper cab.
- 2.13. “*Three-dimensional reference system*” means a coordinate system as defined by appendix 2 to Annex 1 of the Consolidated Resolution on the Construction of Vehicles (R.E.3). In this framework the longitudinal axis of the vehicle is designated the X axis, the lateral axis is the Y axis and the vertical axis is the Z axis.
- 2.14. “*H-point Manikin*” means a three-dimensional H-Point Machine as defined in Annex 1 of the Consolidated Resolution on the Construction of Vehicles (R.E.3).
- 2.15. “*R-Point*” means the seating reference point as defined in Annex 1 of the Consolidated Resolution on the Construction of Vehicles (R.E.3).
- 2.16. “*Accelerator Heel Point*” means the lowest point at the intersection of the heel of the foot and the floor of the vehicle, with the shoe positioned on the Undepressed Accelerator Pedal.
- 2.17. “*P-point*” means the point about which the driver's head rotates when viewing objects on a horizontal plane at eye level. It is located 98 mm rearward of E2 in the X axis.
- 2.18. “*Axle configuration*” means a code of the form AxB where A represents the total number of wheel positions available on the vehicle and B represents the total number of wheel positions where tractive force is applied by the vehicle powertrain. Thus, for example, 6x2 represents a 3-axle vehicle with a wheel positioned at each side of the axle (six wheel positions) with one driven axle (two driven wheel positions). Extended axle configurations considering further subvariations are included within the basic characteristics. Substituting a number for an X means it represents any number. For example, 10xX includes any axle configuration with five axles.

- 2.19. *"Vehicle frontal plane"* means the plane perpendicular to the median longitudinal plane of the vehicle and touching its foremost point, disregarding the projection of devices for indirect vision and any part of the vehicle greater than 2.0 m above the ground.
- 2.20. *"Nearside"* means the right side of the vehicle for right-hand traffic or the left side of the vehicle in left-hand traffic.
- 2.21. *"Nearside Plane"* means the plane parallel to the median longitudinal plane of the vehicle and touching its most outboard point in the nearside direction forward of a position 1.0 m behind the driver ocular reference point, disregarding the projection of devices for indirect vision and any part of the subject vehicle higher than 2.0 m above the ground.
- 2.22. *"Offside"* means the left side of the vehicle for right-hand traffic, or the right side of the vehicle for left-hand traffic.
- 2.23. *"Offside Plane"* means the plane parallel to the median longitudinal plane of the vehicle and touching its most outboard point in the offside direction forward of a position 1.0 m behind the driver ocular reference point, disregarding the projection of devices for indirect vision and any part of the subject vehicle higher than 2.0 m above the ground.
- 2.24. *"Subject vehicle"* means the vehicle being tested.
- 2.25. *"Intended cab mounting angle"* means the pitch and roll angle of the cab floor relative to a horizontal plane with the cab in its nominal design condition.
- 2.26. *"V2 Point"* means a point whose position in the passenger compartment is determined as a function of a vertical longitudinal plane passing through the centre of the driver's designated seating position and in relation to the "R" Point and the design angle of the seat-back, which point is used for verifying compliance.
- 2.27. *"A-pillar"* means any roof support forward of the vertical transverse plane located 68mm in front of the V Point and includes non-transparent items such as windscreen mouldings and door frames, attached or contiguous to such a support.
- 2.28. *"Vehicles of category N₂ and M₂ derived from M₁ or N₁"* means those vehicles of N₂ and M₂ category which, forward of the B-pillars, have the same general structure and shape as a pre-existing M₁ or N₁ category vehicle.
- 2.29. *"Beltline"* means the lower edge of the transparent area, measured in horizontal view, covering the field of vision rearward of the windscreen.

3. Application for Approval

- 3.1. The application for approval of a vehicle type with regard to its Direct Vision shall be submitted by the vehicle manufacturer or by their authorized representative.
- 3.2. It shall be accompanied by the documents mentioned below in triplicate and include the following in particular:
- 3.2.1. A description of the vehicle type with regard to the items mentioned in paragraph 2.2., together with dimensional drawings and the documentation as referred to in Annex 1. The numbers and/or symbols identifying the vehicle type shall be specified. A model of information document is shown in Annex 1.
- 3.3. A vehicle representative of the vehicle type to be approved shall be made available to the Technical Service conducting the approval tests.

4. Approval

- 4.1. If the vehicle type submitted for approval pursuant to this Regulation meets the requirements of paragraph 5. below, approval of that vehicle type shall be granted.
- 4.2. The conformity of the requirements in paragraph 5. shall be verified with the test procedure as defined in paragraph 6., however its operation shall not be limited to these test conditions.
- 4.3. An approval number shall be assigned to each vehicle type approved; its first two digits (00 for this Regulation in its initial form) shall indicate the series of amendments incorporating the most recent major technical amendments made to this Regulation at the time of issue of the approval. The same Contracting Party may not assign the same number to another vehicle type within the meaning of paragraph 2.1 above.
- 4.4. Notice of approval, or of refusal or withdrawal of approval, pursuant to this Regulation shall be communicated to the Parties to the Agreement applying this Regulation by means of a form conforming to the model in Annex 2 to this regulation.
- 4.5. There shall be affixed, conspicuously and in a readily accessible place specified on the approval form, to every vehicle conforming to a vehicle type approved under this Regulation, an international approval mark consisting of:
 - 4.5.1. A circle surrounding the letter "E" followed by:
 - (a) The distinguishing number of the country which has granted approval;¹ and
 - (b) The number of this Regulation, followed by the letter "R", a dash and the approval number to the right of the circle prescribed in this paragraph;
 - or
 - 4.5.2. An oval surrounding the letters "UI" followed by the Unique Identifier.
- 4.6. If the vehicle conforms to a vehicle type approved under one or more other UN Regulations annexed to the Agreement, in the country which has granted approval under this Regulation, the symbol prescribed in paragraph 4.5. above need not be repeated. In such a case, the UN Regulation and approval numbers and the additional symbols shall be placed in vertical columns to the right of the symbol prescribed in paragraph 4.5. above.
- 4.7. The approval mark shall be clearly legible and be indelible.
- 4.8. The approval mark shall be placed close to or on the vehicle data plate.

5. Specifications

- 5.1. General requirements
 - 5.1.1. The visible volume shall be quantified according to the procedures defined in paragraph 6.
 - 5.1.2. Where a vehicle is equipped with more than two A-pillars, then the vehicle manufacturer may select which two pillars will form the boundaries between the nearside, front and offside visible volumes.

¹ The distinguishing numbers of the Contracting Parties to the 1958 Agreement are reproduced in Annex 3 to the Consolidated Resolution on the Construction of Vehicles (R.E.3), document ECE/TRANS/WP.29/78/Rev.6 - <https://unece.org/transport/standards/transport/vehicle-regulations-wp29/resolutions>.

- 5.2. Performance requirements
- 5.2.1. Vehicles shall be assigned into one of the following three levels in accordance with the table of criteria contained in Annex 5:
- 5.2.1.1 Level 1: Vehicles that often travel in urban areas;
- 5.2.1.2 Level 2: Vehicles that sometimes travel in urban areas but have specific operational limitations;
- 5.2.1.3. Level 3: Vehicles that seldom enter urban areas.
- 5.2.2. Vehicles of each level shall achieve visible volumes in excess of the limit values associated with that level as laid down in Table 1.
- 5.2.2.1. Vehicles that meet the criteria laid down in paragraph 2. of Annex 5 shall be deemed to comply with the relevant limit without undertaking the quantification of visible volume as defined in paragraph 6.

Table 1
Minimum Values of Visible Volume

	<i>Minimum Volume (m³) of Direct Vision</i>		
	Level 1	Level 2	Level 3
Nearside Visible Volume	3.4	Not Specified	Not Specified
Front Visible Volume	1.8	1.0	1.0
Offside Visible Volume	2.8	Not Specified	Not Specified
Total Visible Volume	11.2	8.0	7.0

- 5.3. If it can be demonstrated that the reason that a vehicle cannot meet the limit to the front is because of an innovative design, for example where the A-pillars are closer together than in a conventional design, then the vehicle may be deemed to comply if it passes all other applicable limits in addition to the following requirement. This shall be demonstrated by positioning five test objects with equidistant spacing between the vehicle nearside and offside planes. The test objects shall be moved in the longitudinal plane until they are positioned such that the top of the object is just visible from the point E2, through any window/glazed area. The test object shall be a 1.40 m tall pole of 30 mm diameter. A marker point representing a VRU shoulder shall be positioned 0.130 m closer to the vehicle, in the longitudinal plane, than the centre of the pole. The average distance in the longitudinal plane between the vehicle frontal plane and the shoulder marker point for each pole when it is just visible, shall be calculated. For any test object where the shoulder marker point lies to the rear of the frontal plane, a distance of 0.0 m shall be used to calculate the average. The average distance shall be equal to or less than:
- 5.3.1. Level 1: 1.65m
- 5.3.2. Level 2: 1.97m
- 5.3.3. Level 3: 1.97m

6. Test Procedure

- 6.1. Test conditions
- 6.1.1. The test shall be performed on a flat, dry surface of asphalt or concrete construction.
- 6.1.2. The ambient temperature shall be between 0° C and 45° C.

- 6.1.3. The test shall be performed under visibility conditions that clearly allows targets used to quantify the field of view to be correctly observed by a visible light camera.
- 6.2. Vehicle conditions
 - 6.2.1. The subject vehicle shall be the worst-case vehicle of its type in respect of Direct Vision.
 - 6.2.2. The subject vehicle shall be assessed with the accelerator heel point positioned at a height from the ground that is no lower than the midpoint between the height that the manufacturer calculates it would be at for an unladen chassis cab (without body) and that which the manufacturer calculates it would be at when the vehicle is loaded to its technically permissible design maximum.
 - 6.2.2.1. The Accelerator Heel Point shall be measured in accordance with Recommended Practice SAE J1100 Rev. 2009 using the H-Point Manikin. The foot angle (A46) shall be at a minimum of 87° when the H-Point manikin is positioned at the R-Point. For vehicles with R-Point to heel vertical (H30) greater than 405 mm, the accelerator pedal may be depressed as specified by the manufacturer. If the depressed pedal is used, the foot must be flat on the accelerator pedal.
 - 6.2.3. The vehicle cab shall be positioned at the intended mounting angle.
 - 6.2.4. The steering wheel shall be located in the centre of the possible range, considering all axes of adjustment.
 - 6.2.5. Devices for indirect vision (where applicable) shall be adjusted to meet the fields of vision required by UN Regulation No. 46.
 - 6.2.6. Passenger seat (if fitted):
 - 6.2.6.1. For vehicles where a range of passenger seat designs may be specified, the seat selected for evaluation shall be at the discretion of the manufacturer.
 - 6.2.6.2. If the position of the seat is adjustable the passenger seat shall be placed at its rearmost lowest position with a backrest angle of 18° from vertical.
 - 6.2.6.3. Where the selected passenger seat is foldable, the vehicle may be assessed with the seat in the in-use (deployed) or the not-in-use (stowed) position at the discretion of the manufacturer. The single selected seat position shall be applied throughout the whole assessment.
 - 6.2.6.4. Where armrests are adjustable these may be in the in-use (deployed) or the not-in-use (stowed) position at the discretion of the manufacturer.
 - 6.2.6.5. Head restraints shall be in the lowest position suitable for normal use in service. They shall not be in a position provided solely for stowage when not in use.
 - 6.3. Quantifying the visible volume
 - 6.3.1. The visible volume can be quantified indirectly via the physical test method defined in Annex 6. This method measures the length of gridlines on multiple planes as a proxy for volume and converts this mathematically. A tolerance of 0.10 m³ shall be allowed to account for the fact that this method does not correlate perfectly for all designs. This value does not account for measuring tolerances in the execution of the physical test method or for manufacturing tolerances in the construction of the test vehicle.
 - 6.3.2. Alternatively, the visible volume can be quantified directly via a numerical test method as defined in Annex 7, or any numerical method which the manufacturer can demonstrate to the satisfaction of the approval authority produces results at least as accurate as the method defined in Annex 7.
 - 6.4. Annex 7 provides details of a generic cab and suggested tolerance values that represent one example method that can be used, at the discretion of the

manufacturer and approval authority, to demonstrate the accuracy of numerical methods.

7. Modification of Vehicle Type and Extension of Approval

- 7.1. Every modification of the vehicle type as defined in paragraph 2.1. of this Regulation shall be notified to the Type Approval Authority which approved the vehicle type. The Type Approval Authority may then either:
 - 7.1.1. Consider that the modifications made do not have an adverse effect on the conditions of the granting of the approval and grant an extension of approval;
 - 7.1.2. Consider that the modifications made affect the conditions of the granting of the approval and require further tests or additional checks before granting an extension of approval.
- 7.2. Confirmation or refusal of approval, specifying the alterations, shall be communicated by the procedure specified in paragraph 4.4. above to the Contracting Parties to the Agreement applying this Regulation.
- 7.3. The Type Approval Authority shall inform the other Contracting Parties of the extension by means of the communication form which appears in Annex 2 to this Regulation. It shall assign a serial number to each extension, to be known as the extension number.

8. Conformity of Production

- 8.1. Procedures for the conformity of production shall conform to the general provisions defined in Article 2 and Schedule 1 to the 1958 Agreement (E/ECE/TRANS/505/Rev.3) and meet the following requirements:
- 8.2. A vehicle approved pursuant to this Regulation shall be so manufactured as to conform to the type approved by meeting the requirements of paragraph 5. above.
- 8.3. The Type Approval Authority which has granted the approval may at any time verify the conformity of control methods applicable to each production unit. The normal frequency of such inspections shall be once every two years.

9. Penalties for Non-Conformity of Production

- 9.1. The approval granted in respect of a vehicle type pursuant to this Regulation may be withdrawn if the requirements laid down in paragraph 8. above are not complied with.
- 9.2. If a Contracting Party withdraws an approval it had previously granted, it shall forthwith so notify the other Contracting Parties applying this Regulation by sending them a communication form conforming to the model in Annex 2 to this Regulation.

10. Production Definitively Discontinued

If the holder of the approval completely ceases to manufacture a type of vehicle approved in accordance with this Regulation, they shall so inform the Type Approval Authority which granted the approval, which in turn shall forthwith inform the other Contracting Parties to the Agreement applying this Regulation by means of a communication form conforming to the model in Annex 2 to this Regulation.

11. Names and Addresses of the Technical Services Responsible for Conducting Approval Tests and of Type Approval Authorities

The Contracting Parties to the Agreement applying this Regulation shall communicate to the United Nations Secretariat the names and addresses of the Technical Services responsible for conducting approval tests and of the Type Approval Authorities which grant approval and to which forms certifying approval or extension or refusal or withdrawal of approval are to be sent.

Annex 1

Information Document for the Type Approval of a Vehicle with Respect to its Direct Vision

The following information, if applicable, shall be supplied in triplicate and shall include a list of contents.

Any drawings shall be supplied in appropriate scale and in sufficient detail on size A4 paper or on a folder of A4 format.

Photographs, if any, shall show sufficient details.

1. Make (trade name of manufacturer):
2. Type and general commercial description(s):
3. Means of identification of the type:
4. Category of vehicle:
5. Name and address of manufacturer:
6. Location and method of affixing of the approval mark:
- 6.1. Other mean of identification link to the approval mark:
7. Address(es) of assembly plant(s):
8. The dimensions and shapes of the components of the vehicle structure situated in front of a vertical plane positioned 1,000 mm behind the driver's eye point (E2) and perpendicular to the longitudinal plane of the vehicle;
9. The number, size, shape or location of transparent areas of the vehicle situated in front of a vertical plane positioned 1,000 mm behind the driver's eye point (E2) and perpendicular to the longitudinal plane of the vehicle;
10. Other relevant vehicle dimensions (e.g. range of cab heights).

Annex 2

Communication Concerning the Approval or Refusal or Extension or Withdrawal of Approval or Production Definitively Discontinued of a Type of Vehicle with Regard to its Direct Vision

(Maximum format: A4 (210 x 297 mm))



issued by:

(Name of administration)

.....
.....
.....

- Concerning: ²
- Approval granted
 - Approval extended
 - Approval refused
 - Approval withdrawn
 - Production definitively discontinued

of a type of vehicle with regard to its Direct Vision pursuant to UN Regulation No. [XXX]

Approval No.:

1. Trademark:
2. Type and trade name(s):
3. Name and address of manufacturer:
4. If applicable, name and address of manufacturer's representative:
5. Brief description of vehicle:
6. Date of submission of vehicle for approval:
7. Technical Service performing the approval tests:
8. Date of report issued by that Service:
9. Number of report issued by that Service:
10. Reason(s) for extension (if applicable):
11. Approval with regard to Direct Vision is granted/refused:²
12. Place:
13. Date:
14. Signature:
15. Annexed to this communication are the following documents, bearing the approval number indicated above:
16. Any remarks:

•

¹ Distinguishing number of the country which has granted/extended/refused/withdrawn an approval (see approval provisions in this Regulation).

² Strike out what does not apply.

Annex 3

Arrangements of Approval Marks

(see paragraphs 4.5. of this Regulation)

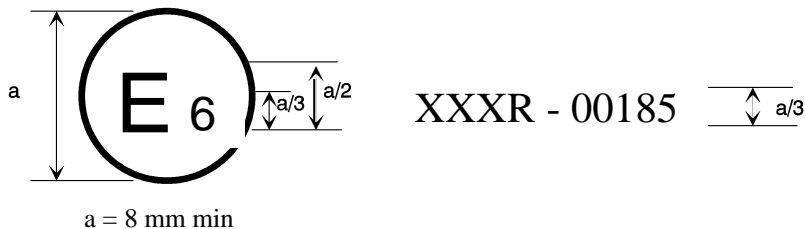

The above approval mark affixed to a vehicle shows that the vehicle type concerned has been approved in Belgium (E6) with regard to Direct Vision pursuant to UN Regulation No. [XXX]. The first two digits of the approval number indicate that the approval was granted in accordance with the requirements of UN Regulation No. XXX in its original form.

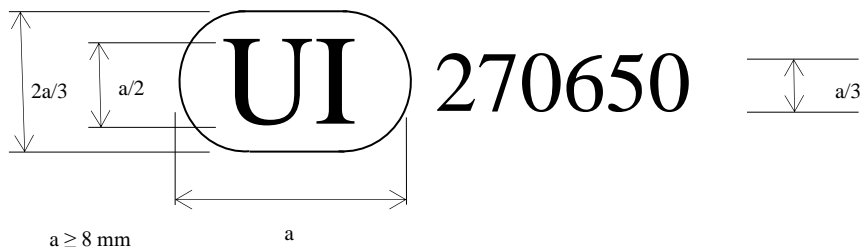

The above Unique Identifier shows that the type concerned has been approved and that the relevant information on that type-approval can be accessed on the UN secure internet database by using 270650 as Unique Identifier. Any leading zeroes in the Unique Identifier may be omitted in the approval marking.

Annex 4

Assessment Volume

1. The assessment volume shall be defined as the volume of space between the frontal, nearside and offside plane of the vehicle and the horizontal and vertical boundaries of the assessment zone as defined below and illustrated in Figure 1.
 - 1.1. The forward boundary of the assessment zone shall be formed by a plane parallel to the vehicle frontal plane and positioned 2,000 mm forward of the vehicle frontal plane.
 - 1.2. The nearside boundary of the assessment zone shall be formed by a plane parallel to the vehicle nearside plane and positioned 4,500 mm further to its nearside.
 - 1.3. The offside boundary of the assessment zone shall be formed by a plane parallel to the vehicle offside plane and positioned 2,000 mm further to its offside.
 - 1.4. The rearward boundary of the assessment zone shall be formed by a plane parallel to the vehicle frontal plane and positioned 1,000 mm behind the driver's eyepoint (E2).
 - 1.5. The vertical boundaries of the assessment zone shall be formed by the ground plane and a plane parallel to the ground plane but positioned 1,602 mm above the ground.

Figure 1
Definition of the Assessment Volume, Based on a Category N₃ Vehicle as an Example

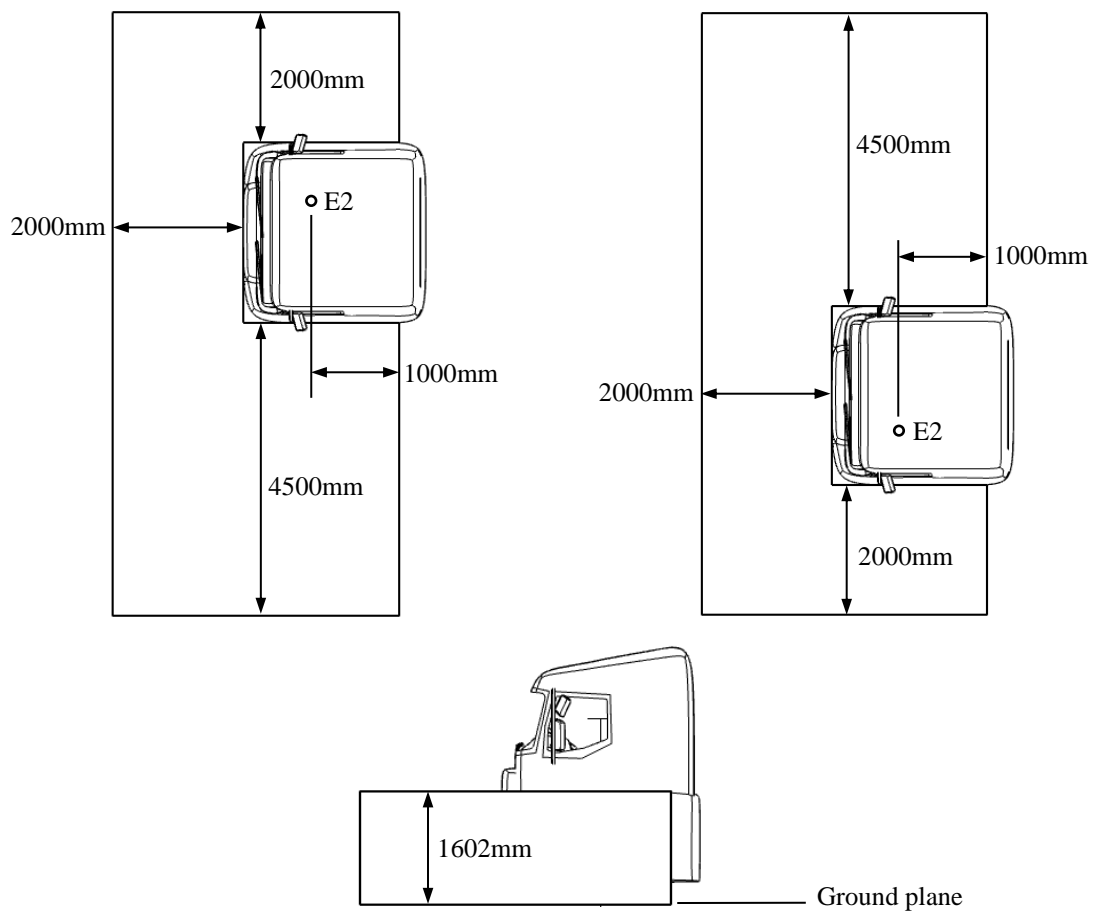

Annex 5

Assigning Vehicles to Direct Vision Levels and Compliance Methods

1. Assignment of direct vision levels shall be according to Table 1, below.

Table 1
Assignment of Vehicles to Direct Vision Levels

<i>Direct Vision Level</i>	<i>Gross Weight (tonnes)</i>	<i>Chassis Execution</i>	<i>Axle Config</i>	<i>Engine Power (kW)</i>	<i>Cab type</i>	<i>Vehicle Category</i>	
Level 1	≤ 7.5	All	All	All	All	N2, N2G	
	> 7.5	All	All	All	All	N2	
	All	All	All	All	All	M2	
	All	All	All	All	All	M3	
	≤ 16	All	4x2	All	All	N3	
				6x2; 6x4			
				8x2; 8x4			
	> 16	Articulated	4x2	All	Day	N3	
				<265	Sleeper	N3	
				6x2	All	Day	N3
		Rigid	4x2	All	Day	N3	
				<265	Sleeper	N3	
				6x2	All	Day	N3
				6x4	All	Day	N3
			8x2	<350	Sleeper	N3	
			8x4				
Level 2	> 7.5	All	4x4	All	All	N2G	
	≤ 16	All	4x2	All	All	N3G	
				6x4			
				8x4			
	> 16	Articulated	4x2	All	Day	N3G	
				<265	Sleeper	N3G	
		Rigid	4x2	All	Day	N3G	
				<265	Sleeper	N3G	
			6x4	All	Day	N3G	
			8x4	<350	Sleeper	N3G	
Level 3	> 16	Articulated	4x2	≥ 265	Sleeper	N3, N3G	
			6x2	All	Sleeper	N3	

<i>Direct Vision Level</i>	<i>Gross Weight (tonnes)</i>	<i>Chassis Execution</i>	<i>Axle Config</i>	<i>Engine Power (kW)</i>	<i>Cab type</i>	<i>Vehicle Category</i>
			6x4	All	All	N3, N3G
			8x2			
			8x4			
		Rigid	4x2	≥265	Sleeper	N3, N3G
			6x2	All	Sleeper	N3
			6x4	≥350	Sleeper	N3, N3G
			8x2			
			8x4			
All	All		4x4	All	All	N3, N3G
			6x6			
			8x6			
			8x8			
			10xX			

2. Eligibility for use of the alternative demonstration of compliance
- 2.1. Subject to the choice of the manufacturer, vehicles of category M₂ and N₂ not equipped with either mirrors of Class V or VI according to UN Regulation No. 46 shall be deemed to comply with the requirements when at least one of the conditions defined in paragraph 2.1.1. or 2.1.2. are met:
- 2.1.1. When measured according to the procedure described in 2.1.1.1. the vertical distance of the beltline from ground is lower than 1,450 mm or the vertical distance between the beltline of the vehicle and the eye point is greater than 260 mm. In these cases, the vehicle must additionally meet the provisions of paragraph 2.1.1.2.
- 2.1.1.1. Determination of beltline heights:
- The seat shall be adjusted to the R-point as defined by the manufacturer.
- The position of the eye point V2 relative to the R-point shall be created using the distances described in Tables 2 and 3 of paragraph 2.2.
- Without any further adjustments to the seating height, the seat shall be moved from the R-point position to the midpoint between the most forward and most rearward position of travel. If this position is between two notches, the next rearward notch shall be used. The eye point shall be moved colinearly to the seat from the R-point to the mid-position.
- The measurement shall be done in a plane perpendicular to the longitudinal direction of the vehicle and intersecting with this eye point.
- The exterior height of the beltline is its vertical distance from the ground. If any of below exempted parts intersect with the beltline in this plane, the height of the beltline shall be assessed at the next rearward unobstructed position.
- The interior height of the beltline is its vertical distance to the eye point. If any of below exempted parts intersect with the beltline in this plane position, the height of the beltline shall be assessed at the next rearward unobstructed position.
- When measuring the beltline distances:

- (a) fixed or movable vents;
- (b) side window division bars;
- (c) outside radio aerials;
- (d) devices for indirect vision, covering the mandatory field of indirect vision;
- (e) embedded or printed "radio aerial" conductors, no wider than 0.5 mm;
- (f) inside or outside handlebars;
- (g) parts mounted to the interior of the driver's compartment, like seats or consoles

shall be exempted. Any parts of glazing covered with dot-printed areas shall be considered as non-transparent.

2.1.1.2. A 1,200 mm tall cylindrical object with a diameter of 300 mm that is situated inside the space bounded by a vertical plane located 2,000 mm in front of the vehicle, a vertical plane located 2,300 mm in front of the vehicle, a vertical plane located 400 mm from the driver's side of the vehicle, and a vertical plane located 600 mm from the opposite side of the vehicle shall be at least partially visible when viewed directly from V2 (see Figure 1), regardless of where the object is within that space, unless it is invisible due to a blind spot(s) created by the A-pillars, windscreen wipers, or steering wheel.

If the driver's seat is located in the central driving position of the vehicle, the 1,200 mm tall cylindrical object shall be situated inside the space bounded by a vertical plane located 2,000 mm in front of the vehicle, a vertical plane located 2,300 mm in front of the vehicle, a vertical plane located 500 mm from the side of the vehicle (see Figure 2).

Figure 1
Figure Title

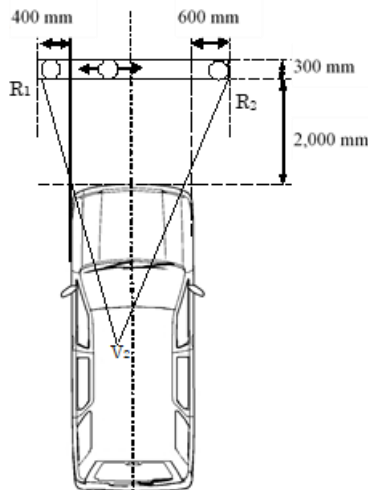
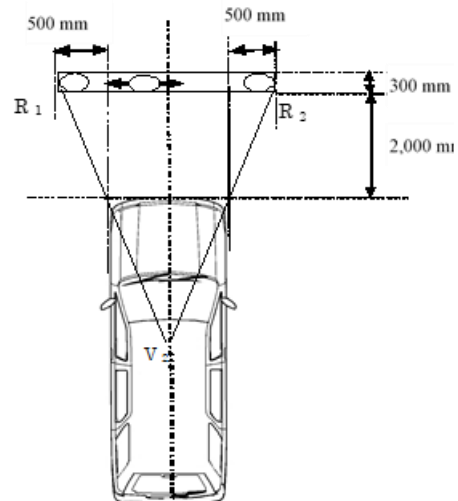

Figure 2
Figure Title



2.1.2. Vehicles of category M₂ and N₂, derived from M₁ or N₁ approved to UN Regulation No. 125, shall be considered to have satisfied the requirements on direct vision.

2.2. Position of the V2 point

2.2.1. The position of the V2 point in relation to the "R" point, as indicated by XYZ coordinates from the three dimensional reference grid, are as shown in Table 2 and Table 3 below.

2.2.2. Table 2 indicates the basic coordinates for a design seat-back angle of 25°.

Table 2
Position of the Point V2 for a Design Seat-Back Angle of 25°

<i>V-point</i>	X	Y	Z
V ₂	68 mm	-5 mm	589 mm

2.2.3. Correction for design seat-back angles other than 25°

Table 3 indicates the further corrections to be made to the X and Z coordinates of each V point when the design seat-back angle is not 25°.

Table 3
Corrections to the Point V2 for Different Seat Back Angles

<i>Seat-back angle (in °)</i>	<i>Horizontal coordinates Δx</i>	<i>Vertical coordinates Δz</i>	<i>Seat-back angle (in °)</i>	<i>Horizontal coordinates Δx</i>	<i>Vertical coordinates Δz</i>
5	-186 mm	28 mm	23	-18 mm	5 mm
6	-177 mm	27 mm	24	-9 mm	3 mm
7	-167 mm	27 mm	25	0 mm	0 mm
8	-157 mm	27 mm	26	9 mm	-3 mm
9	-147 mm	26 mm	27	17 mm	-5 mm
10	-137 mm	25 mm	28	26 mm	-8 mm
11	-128 mm	24 mm	29	34 mm	-11 mm
12	-118 mm	23 mm	30	43 mm	-14 mm
13	-109 mm	22 mm	31	51 mm	-18 mm
14	-99 mm	21 mm	32	59 mm	-21 mm
15	-90 mm	20 mm	33	67 mm	-24 mm
16	-81 mm	18 mm	34	76 mm	-28 mm
17	-72 mm	17 mm	35	84 mm	-32 mm
18	-62 mm	15 mm	36	92 mm	-35 mm
19	-53 mm	13 mm	37	100 mm	-39 mm
20	-44 mm	11 mm	38	108 mm	-43 mm
21	-35 mm	9 mm	39	115 mm	-48 mm
22	-26 mm	7 mm	40	123 mm	-52 mm

Annex 6

Physical Test Method

0. The physical test method calculates the visible volume by mapping out the area of 8 horizontal planes forming sections through the assessment volume, that is visible from the three E points. The view from each E point is provided by a camera mounted in the specified location. The area that can be seen from each E point is mapped via the visibility of a calibrated marker object positioned on grid lines within the assessment area relevant to each eye point. The resulting visible area is scaled to quantify the visible volume.

Figure 1

Example of the Visible Lines Identified for the Driver's Side Window

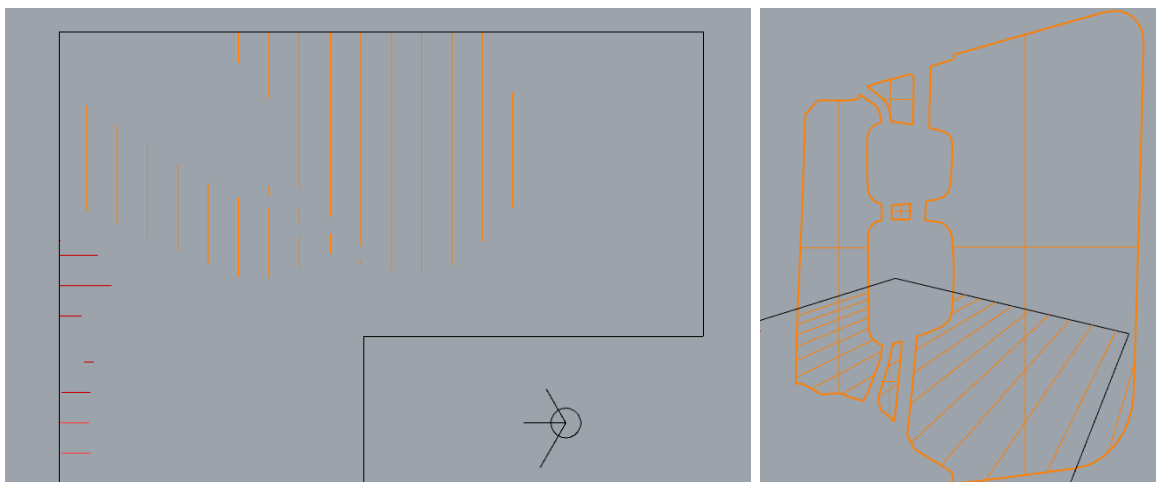

1. Assessment area
- 1.1. The assessment area shall be defined by 8 planes parallel to the ground plane (X-Y plane) at height offsets defined in Table 1 below and bounded by the assessment volume as defined in Annex 4.

Table 1
Height of Assessment Area Planes

<i>Reference</i>	<i>Height above ground plane (mm)</i>
A	200
B	400
C	600
D	800
E	1 000
F	1 200
G	1 400
H	1 600

2. Assessment area grid
- 2.1. The assessment area grid is formed by a series of lines parallel to the median longitudinal plane of the vehicle (X) and perpendicular to the median longitudinal plane of the vehicle (Y) spaced at 100mm intervals, bounded by the assessment areas as defined in paragraph 1.1.

Figure 2
Dividing the Assessment Area Into a Grid

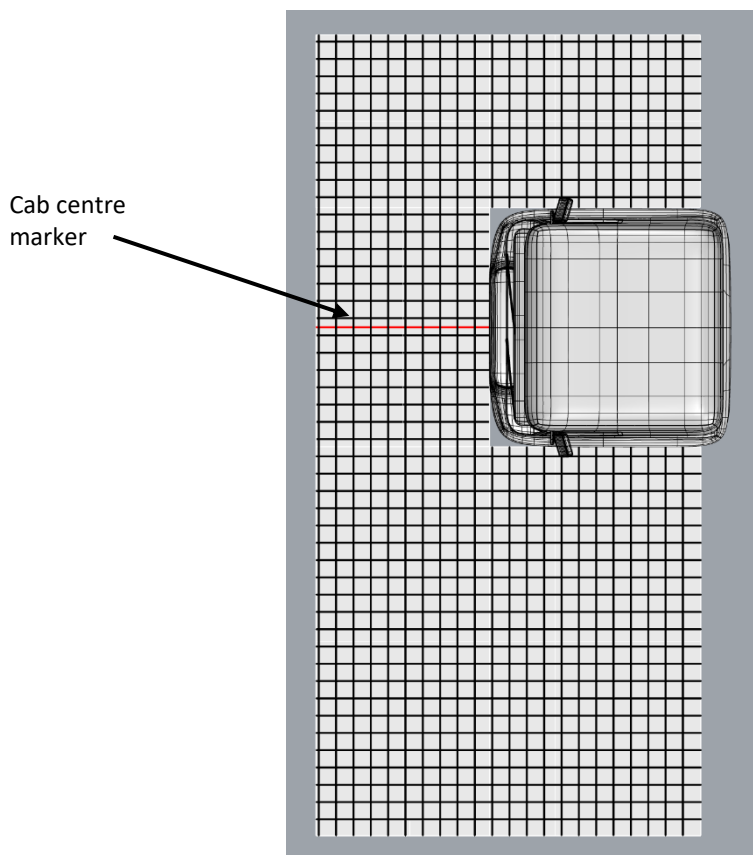

3. Visible line length
 - 3.1. The total visible line length is the length of the gridlines contained entirely within the assessment area that is visible from one of the E-points. It is the sum of the visible line lengths to each side, as defined in paragraphs 3.2., 3.3. and 3.4.
 - 3.2. The nearside visible line length is the length of grid lines that are visible on the assessment plane from the point E1 for right-hand traffic or E3 for left-hand traffic and through any transparent area positioned to the rear of the A-pillar on the near side of the vehicle, where the view from the driver's seat would predominantly lie outboard of the nearside plane of the vehicle. Line length measured from the point E1 or E3 shall include only lines that are perpendicular to the median longitudinal plane of the vehicle.
 - 3.3. The front visible line length is the length of gridlines within the assessment area that are visible on the assessment plane from the point E2 and through any transparent area positioned between the A-pillars of the vehicle, where the view from the driver's seat would predominantly lie forward of the frontal plane of the vehicle. Line length measured from the point E2 shall include only lines that are parallel to the median longitudinal plane of the vehicle.
 - 3.4. The offside visible line length is the length of the gridlines within the assessment area that are visible on the assessment plane from the point E3 for right-hand traffic or E1 for left-hand traffic, and through any transparent area positioned to the rear of the A-pillar on the offside of the vehicle, where the view from the driver's seat would predominantly lie outboard of the offside plane of the vehicle. Line length measured from the point E3 or E1 shall include only lines that are perpendicular to the median longitudinal plane of the vehicle.
 - 3.5. The definition of visible line length is illustrated in Figure 3 to Figure 5 below.

Figure 3
Use of Gridlines for Assessing Different Views to Each Side Based on an Example Intended for Left-hand Traffic

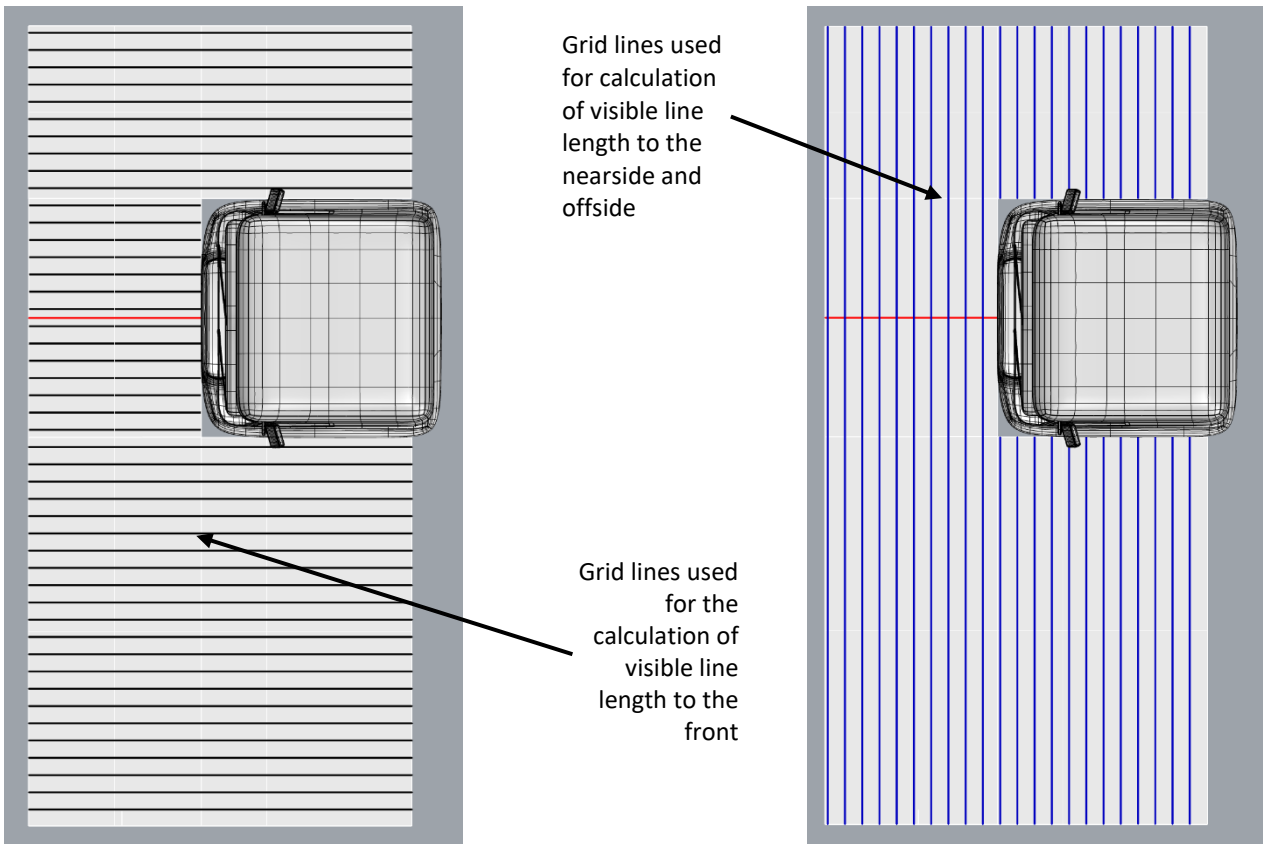

Figure 4
Visible Line Length to Each Side Representing the Intersection of the Sightlines Projected from the E-points and the Assessment Area Based on an Example Intended for Left-hand Traffic

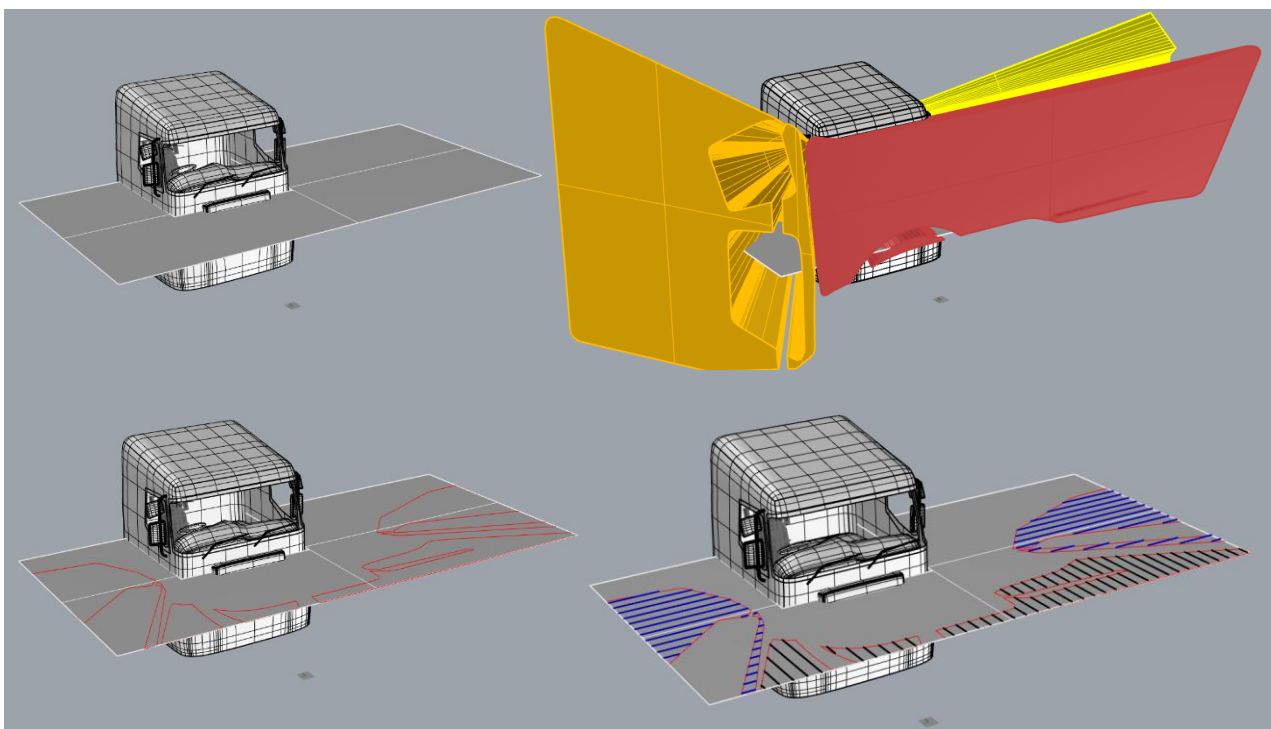
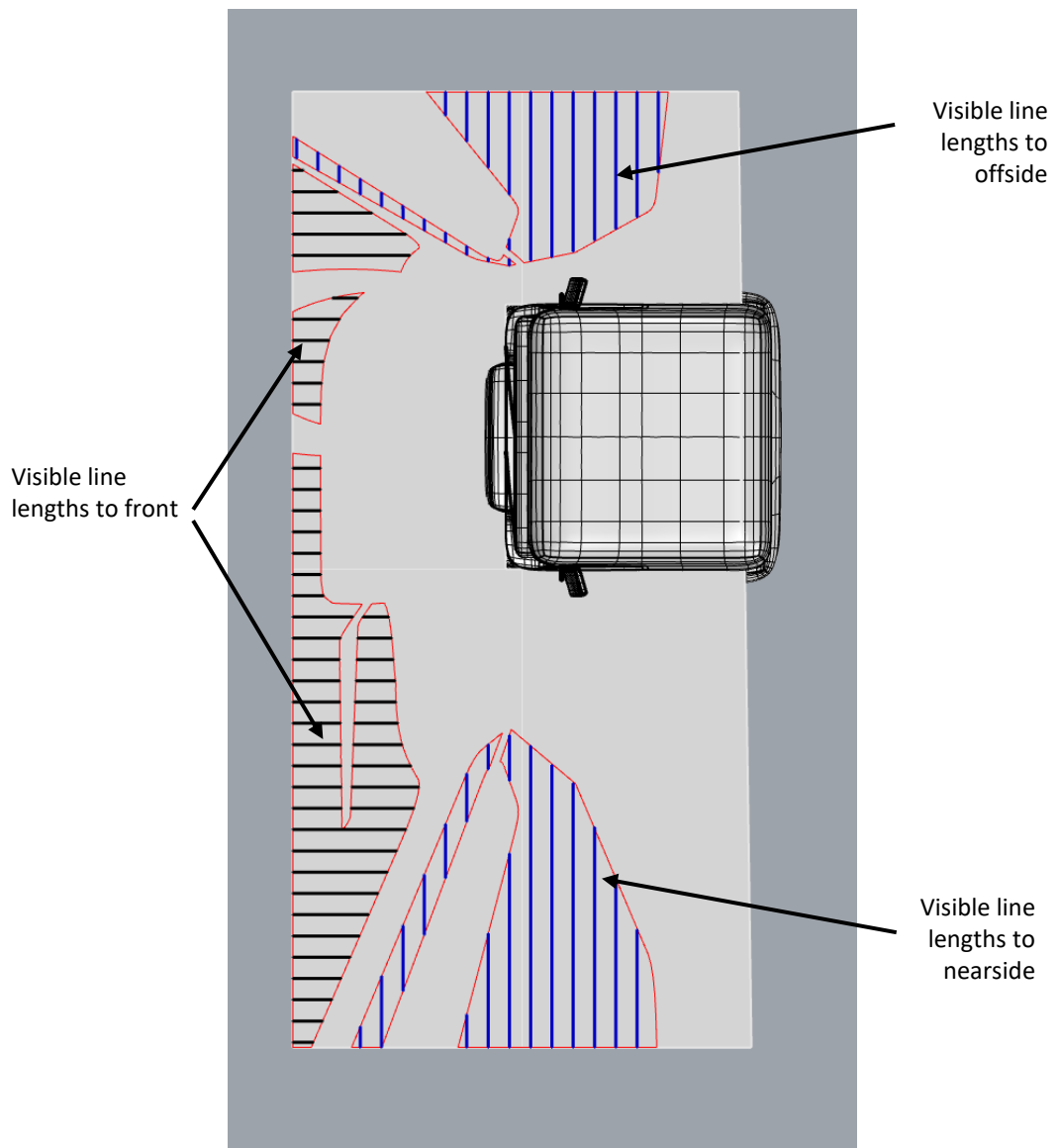
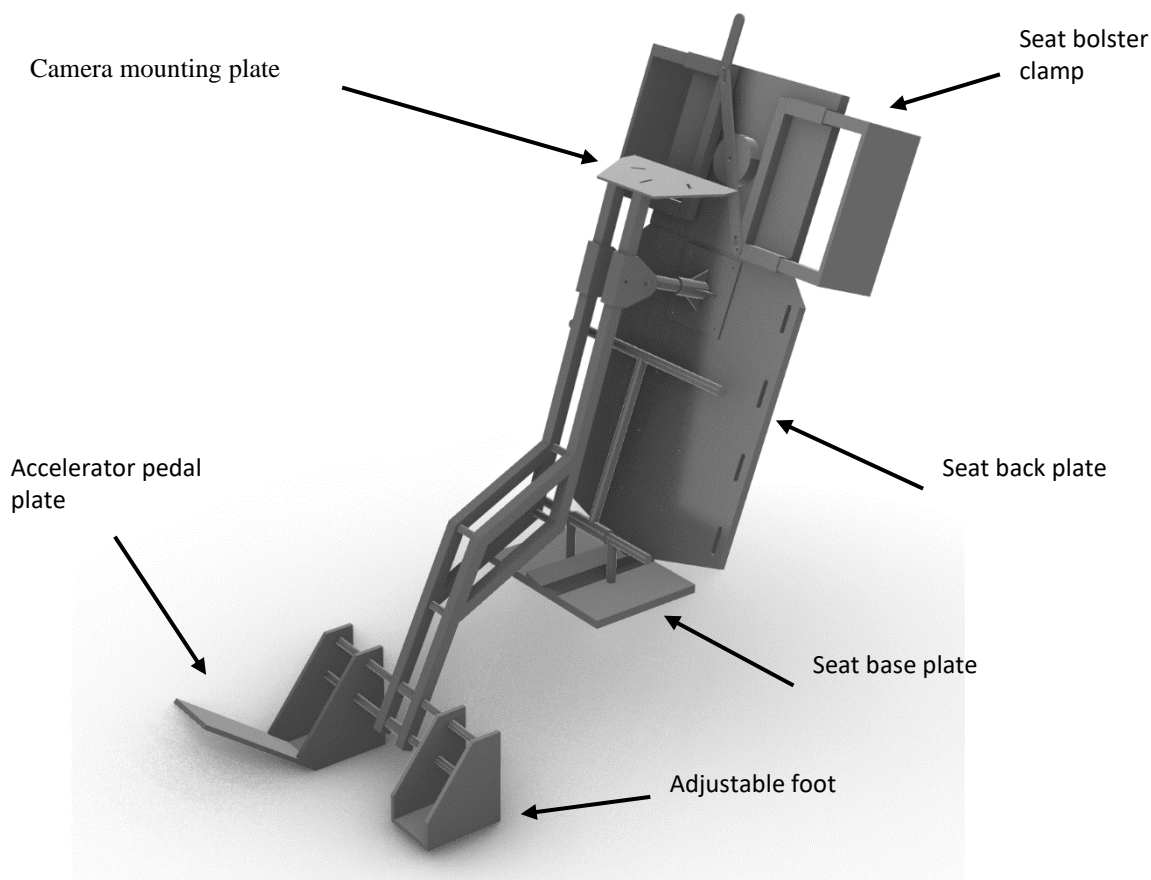

Figure 5
Visible Line Lengths to Each Side Based on an Example Intended for Left-Hand Traffic



4. Physical test procedure setup
 - 4.1. Assessment device
 - 4.1.1. The field of view from each of the eye points E1, E2 and E3 shall be assessed using a suitable device mounted at the relevant eyepoint.
 - 4.1.2. The device may be a receiver, e.g. a camera, with a sufficient field of view to enable all transparent areas to be visible to a given side from the associated E-point.
 - 4.1.3. Alternatively, the device may be an emitter (e.g. laser) relying on a receiver on the marker object (see paragraph 4.3) to establish line of sight.
 - 4.2. Positioning the assessment device at the eye points
 - 4.2.1. The assessment device shall be positioned at the points E1, E2, and E3.
 - 4.2.2. The method used to achieve this shall be both accurate and robust such that positioning error is minimised.
 - 4.2.3. This may be achieved, for example, by use of a physical test apparatus such as that illustrated in Figure 6 below.

Figure 6
Example of Test Apparatus Suitable for Positioning Cameras at the Defined Eye Points E1, E2 and E3



- 4.3. Marking the assessment grid
- 4.3.1. The assessment grid shall be defined at the ground plane by any suitable means (e.g. permanent floor markings, a removable mat suitably aligned to the vehicle, a laser projection onto the floor, or using a test rig with movable components and accurate measurement and control built in).
- 4.3.2. The assessment grid shall be transposed to the required height by the use of an appropriate marker object. For example, a rigid vertical 30 mm diameter pole, mounted perpendicular to the ground plane. Points representing the required heights of each of the e assessment planes shall allow confident identification that they will be visible from the relevant eye point (e.g. high contrast colour, or high lumen light source for detection in an eye point camera view, or high accuracy receiver for a laser output from the eye point).
- 4.3.3. The base of the marker object should be designed and constructed such that it's centreline can be easily and accurately aligned with the assessment grid and efficiently moved around the grid.
5. Evaluation procedure
- 5.1. The evaluation consists of moving the marker object along each line of the assessment grid and determining the length of each line that is visible from the appropriate eye point (E1, E2, or E3).
- 5.2. The assessment shall be repeated such that the nearside visible line length, the frontal visible line length and the offside visible line length can all be identified separately.

- 5.3. Determine the working order for the assessment (e.g. front to back, left to right) and incrementally assess the full length of each gridline for visibility.

Figure 7

Determine Working Order in Which to Progress Through the Lines on the Assessment Grid Based on an Example Intended for Left-hand Traffic

Determine working order, direction does not matter but consistency is important

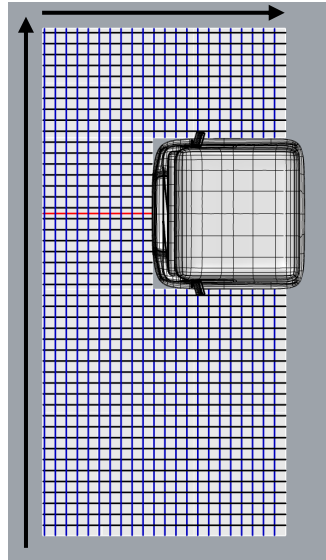

- 5.4. Position the marker object at the maximum extent of the relevant assessment grid on the first appropriate grid line. For example, for the front assessment grid, this might be the bottom left corner of the mat.
- 5.5. Align the marker at the base of the marker object with the gridline.

Figure 8

Example: Alignment of a Simple Marker Object with Pre-Marked Gridlines on the Ground

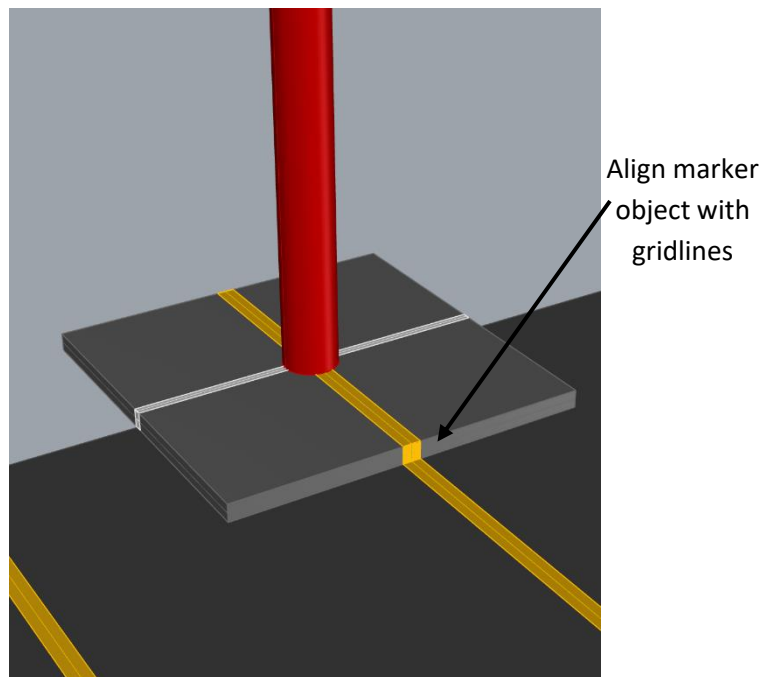

- 5.6. For each relevant line in the assessment area, determine the length of line for which the markings representing each assessment area height are visible from the relevant eye point:

- 5.6.1. For each relevant assessment height, record the distance from the edge of the assessment area grid to the marker object where the relevant height can be seen. Table 2 can be used for this purpose. If the marker object is at the edge of the assessment area, the distance to be recorded will be zero.
- 5.6.1.1. This marks the start of the first visible line length for this gridline.
- 5.6.1.2. Move the marker along the line until it reaches the point at which the relevant assessment plane height is still visible but just about to become obscured by the vehicle structure (see Figure 9). Record this distance in Table 2.
- 5.6.1.3. This marks the end of the first visible line length for this gridline.
- 5.6.1.4. If the marker object reaches the end of the gridline before it becomes obscured, record the distance from the edge of the assessment area to the marker object positioned at the end of the gridline.

Figure 9
Positioning of MO to Identify Portions of Gridlines in Which the Assessment Plane Height is Visible

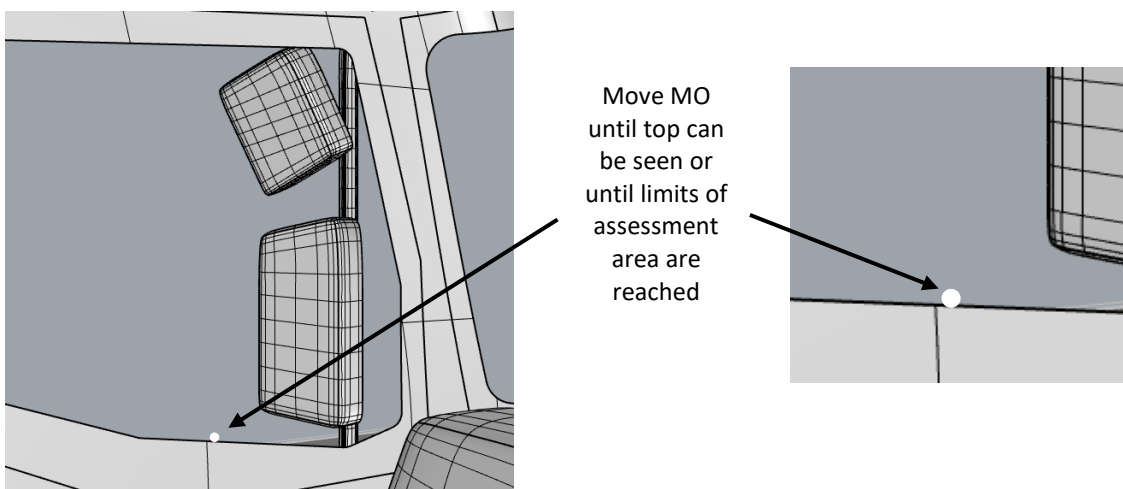
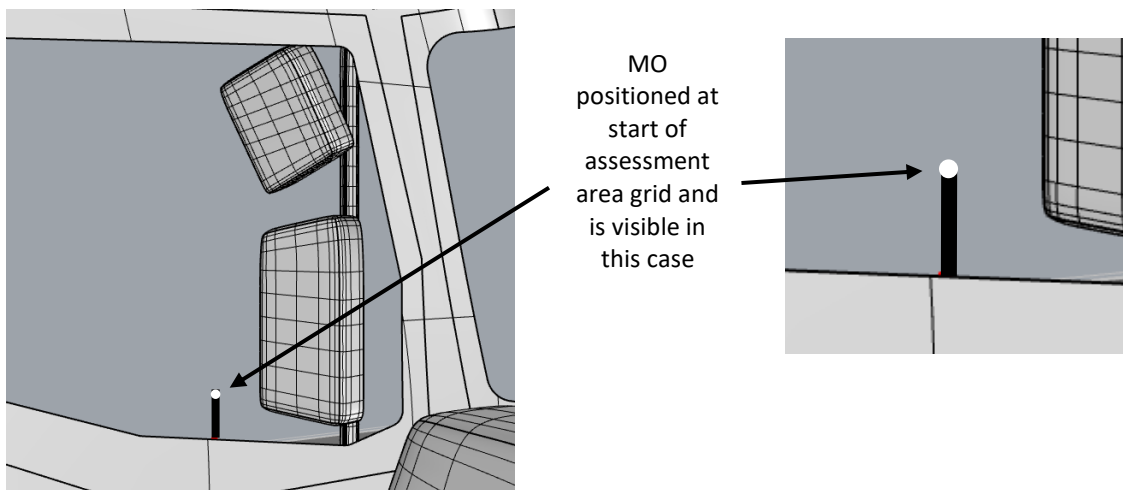

- 5.6.2. If the marker at the relevant assessment plane height cannot be seen, move the marker object along the gridline until the point at which the assessment plane height is visible or until the limits of the assessment area are reached:
- 5.6.2.1. If the assessment plane height becomes visible, record the distance from the edge of the assessment area grid to the marker object in Table 2.

- 5.6.2.2. If the top of the marker object is not visible across the entire gridline, record "zero" in Table 2 and move to the next gridline.
- 5.6.3. For some gridlines there may be multiple visible line lengths on the same gridline. For each visible segment, record the distance from the edge of the assessment area to the start of each visible line and from the edge of the assessment area to the end of each visible line.
- 5.6.4. In some instances, the full grid line will be visible. There is no need to capture measurements in this case, merely record "full" or the appropriate length, e.g. 2,000 mm to the front, 2,000 mm to the offside or 4,500 mm to the nearside.
- 5.6.5. When assessment of a single gridline is complete, move to the next.
- 5.6.6. Repeat the process for every gridline for each assessment zone, working from one end to the other.
- 5.6.7. The full extent of each zone must be evaluated (see Figure 10).

Figure 10
Use of Assessment Grid Zones Based on an Example Intended for Left-hand Traffic

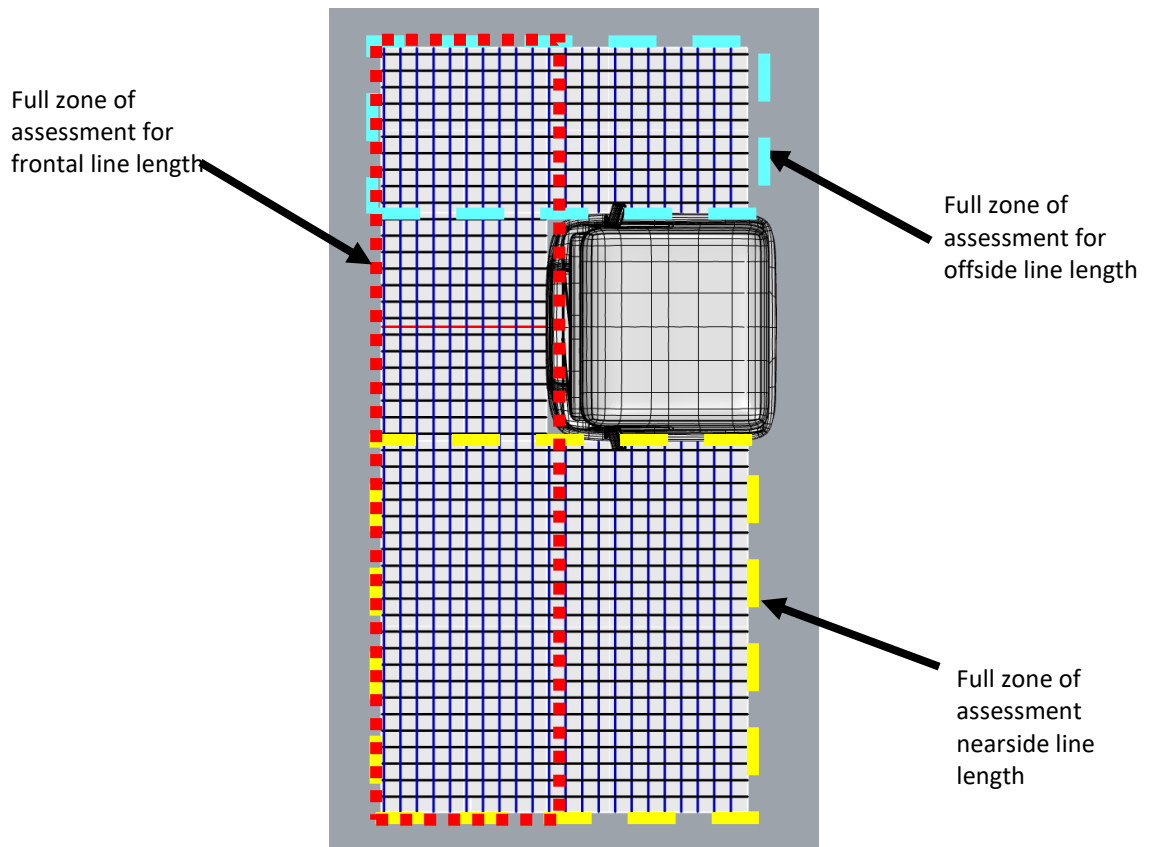

- 5.7. Once all visible line lengths have been recorded, each of the nearside, front and offside visible line lengths shall be calculated as follows:

$$\text{Visible Line Length} = \sum_{1}^{n^{\text{th}} \text{ gridline}} (\text{end of } 1^{\text{st}} \text{ visible line length} - \text{start of } 1^{\text{st}} \text{ visible line length}) + (\text{end of } 2^{\text{nd}} \text{ visible line length} - \text{start of } 2^{\text{nd}} \text{ visible line length}) + (\text{end of } n^{\text{th}} \text{ visible line length} - \text{start of } n^{\text{th}} \text{ visible line length})$$

Table 2
Result Template

View	Grid-line	Visible part 1			Visible part 2			Visible part N			Total visible length per line
		Start	End	Length	Start	End	Length	Start	End	Length	
Nearside	1										
	2										
	n										
	Total Visible Line Length Nearside										
Front	1										
	2										
	n										
	Total Visible Line Length Front										
Offside	1										
	2										
	n										
Total Visible Line length Offside											

6.1. Calculating the visible volume

6.1.1. The nearside visible line length (mm) is converted into Nearside Visible Volume (mm³) as follows:

$$\text{Nearside Visible Volume} = \frac{\text{Nearside visible line length}}{0.0000533039} - 12,242.9140675966$$

6.1.2. The front visible line length (mm) is converted into Front Visible Volume (mm³) as follows:

$$\text{Front Visible Volume} = \frac{\text{Front visible line length}}{0.0000593932} - 13,715.5591368016$$

6.1.3. The offside visible line length (mm) is converted into Offside Visible Volume (mm³) as follows:

$$\text{Offside Visible Volume} = \frac{\text{Offside visible line length}}{0.0000476507} - 19,740.9599226577$$

Annex 7

Numerical Test Method

1. Properties of the model
 - 1.1. The CAD model used in the assessment shall include all necessary features and geometry to provide an accurate representation of what would be visible from the defined eye points in a physical vehicle suitable for sale.
 - 1.2. The CAD model should include all possible vision occlusions.
 - 1.3. The CAD software used is at the discretion of the manufacturer, but the manufacturer shall demonstrate to the approval authority that the results produced are reliable. The process of measuring the generic cab defined in Annex 7, paragraph 5 is one example of a method that can be used for that purpose.
2. Create the assessment volume:
 - 2.1. The assessment volume shall be created within the CAD environment.
3. Define the vision opening lines:
 - 3.1. To define the nearside vision opening line, the view point within the model shall be positioned at the point E1 for left-hand traffic or E3 for right-hand traffic. For the frontal vision opening line the view point within the model shall be positioned at the point E2 and for the offside vision opening line at the point E3 for left-hand traffic and E1 for right-hand traffic.
 - 3.2. From this visual perspective, the vision opening line shall be drawn around the edges of the transparent area and its intersections with vision occlusions. Examples are shown in Figure 1 below.

Figure 1
Examples of Drawing Vision Opening Lines (Yellow) for the Frontal View (Top), Left View (Left) and Right View (Right) in a CAD Environment Based on an Example Intended for Left-hand Traffic

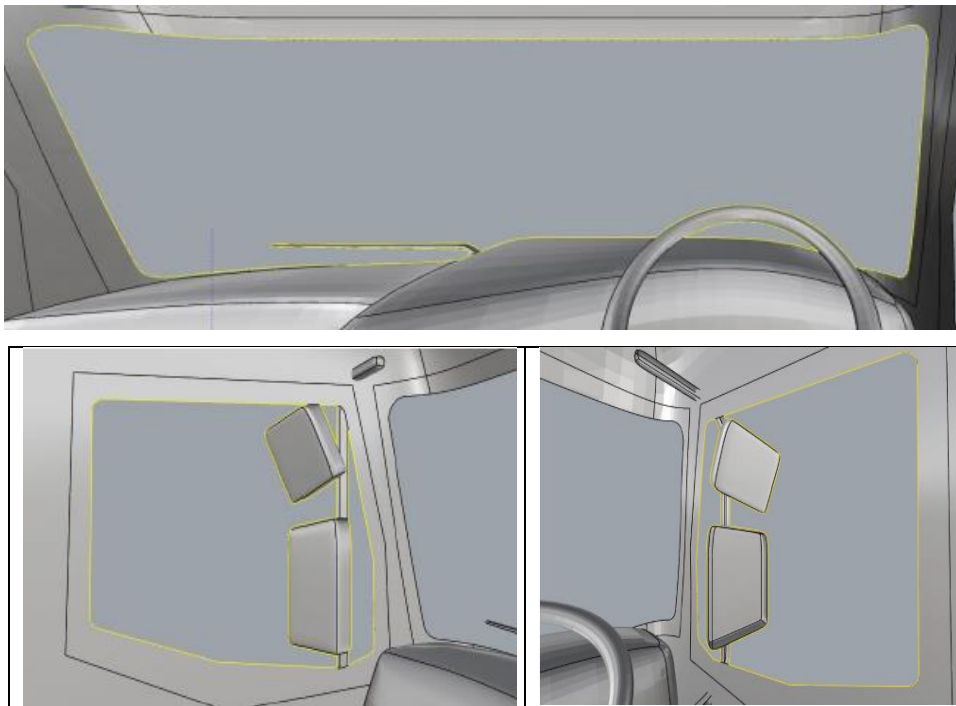

4. Define three-dimensional driver views
 - 4.1. From the eye point E1, project sight lines that intersect with the vision opening lines defining the left view from the vehicle, into the space outside of the vehicle until they either meet the ground or project beyond the assessment volume.
 - 4.2. From the eye point E2, project sight lines that intersect with the vision opening lines defining the frontal left view from the vehicle, into the space outside of the vehicle until they either meet the ground or project beyond the assessment volume.
 - 4.3. From the eye point E3, project sight lines that intersect with the vision opening lines defining the right view from the vehicle, into the space outside of the vehicle until they either meet the ground or project beyond the assessment volume.
 - 4.4. Examples of three-dimensional driver's views are shown in Figure 2 below.

Figure 2

Examples of Driver's Left View (Top), Frontal View (Middle) and Right View (Bottom) Projected from E1, E2, and E3 Respectively Based on an Example Intended for Left-hand Traffic

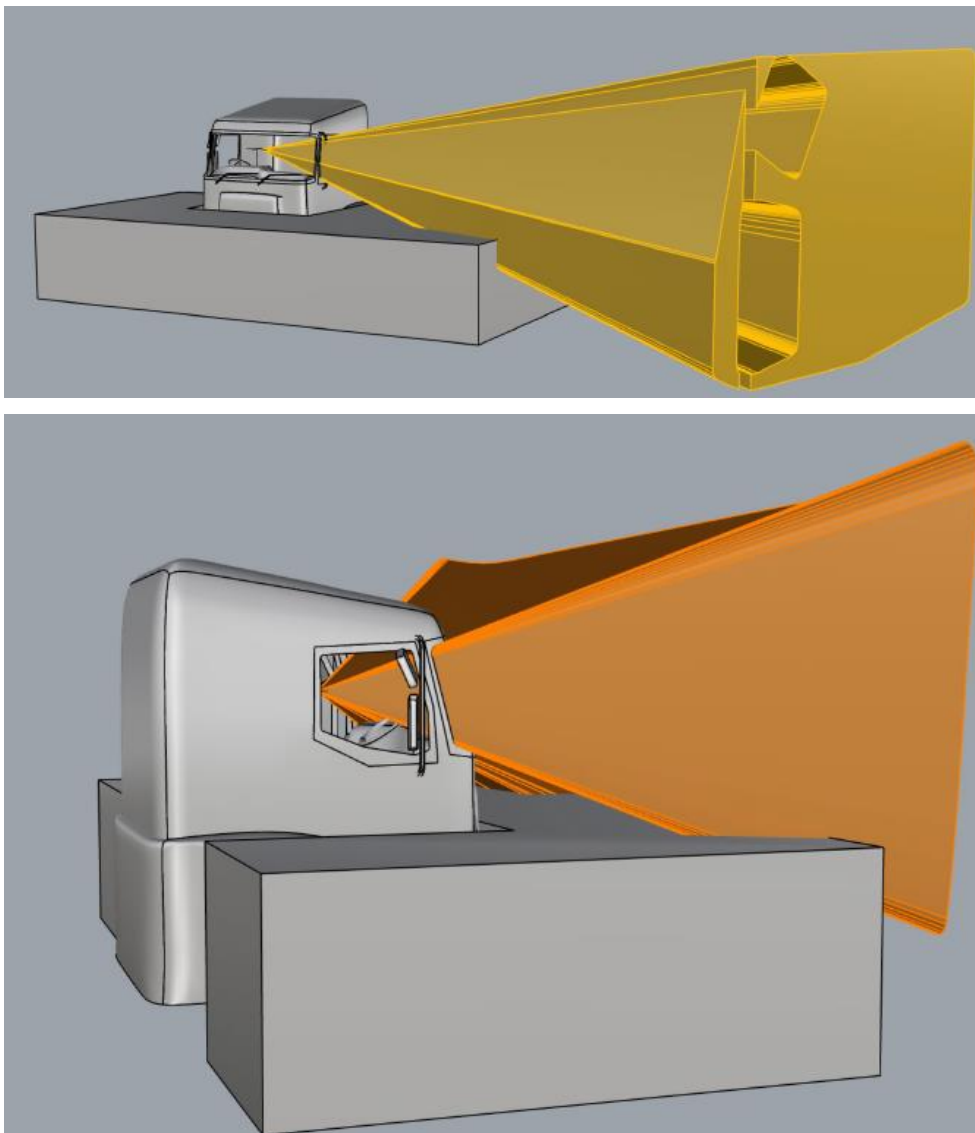

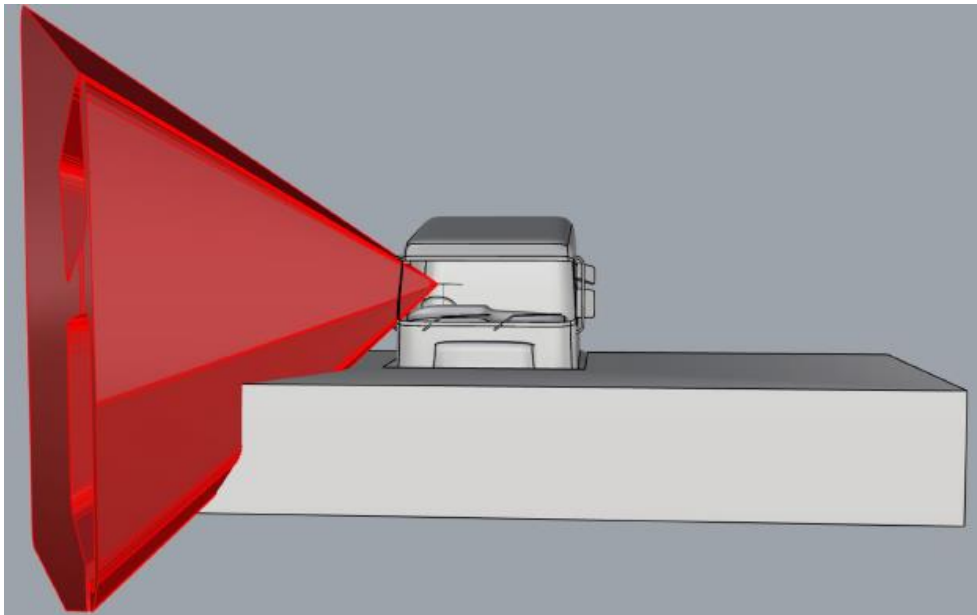

5. Calculating the visible volume
- 5.1. Each of the views to the driver’s nearside, front, and offside shall be constrained to only those volumes that are within the assessment zone (the visible volume to each side). The remaining volumes of space shall be designated as:
 - 5.1.1. The nearside visible volume;
 - 5.1.2. The front visible volume;
 - 5.1.3. The offside visible volume.
- 5.2. The total visible volume is the sum of the visible volumes to each side.
- 5.3. An example of the result is shown in Figure 3 below.

Figure 3
Example of Visible Volume (RHD) Vehicle. Visible Volume (Nearside Yellow, Front is Orange, Offside Red) Based on an Example Intended for Left-hand Traffic

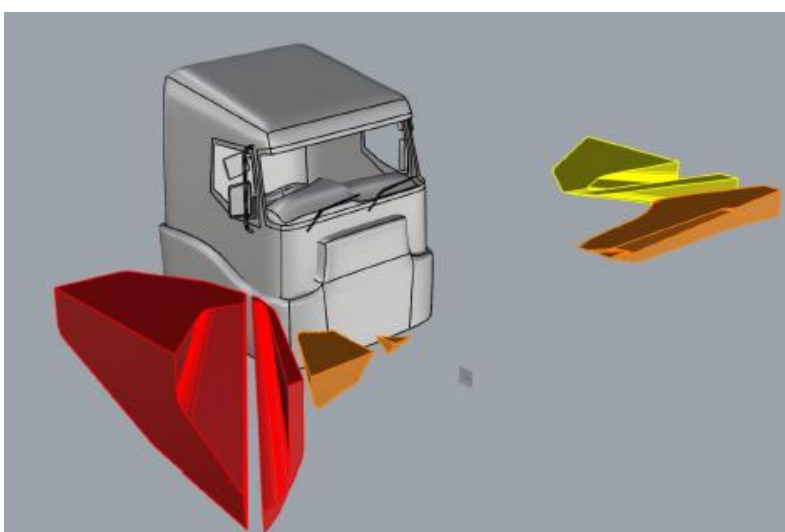

6. Using the generic truck model to validate the use of numerical methods.
 - 6.1. The process defined in paragraphs 1. to 5. of this annex shall be applied to a standardised generic truck model.
 - 6.2. The generic model is illustrated in Figure 4, below.

Figure 4
Illustration of the Generic Cab Model

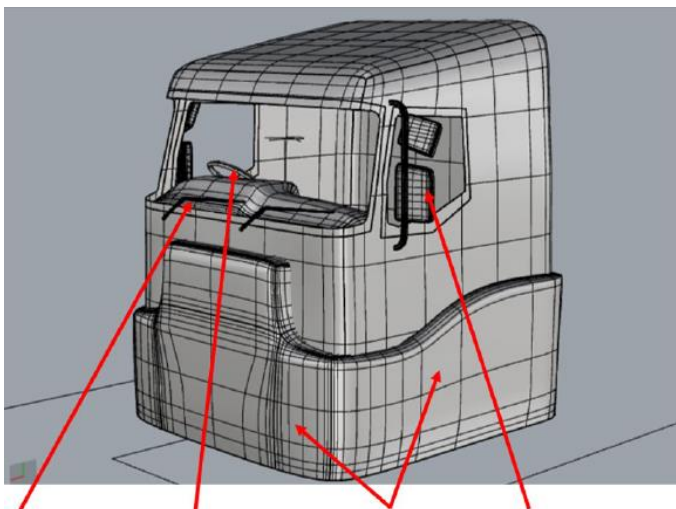

Windscreen wipers that obscure view	Sections of steering wheel that obscure view	Bumpers of wheel arches that extend beyond the rest of the cab	Mirror mounts or support structures that obscure view
-------------------------------------	--	--	---

- 6.3. The full 3-D model for use in this assessment is available in .stp format.¹
- 6.4. The results of the assessments shall fall within the limits defined in Table 1, below.

Table 1
Expected Nominal Results from the Assessment of the Generic Cab and Permitted Limits

<i>Visible Volume</i>	<i>Expected Volume (mm³)</i>	<i>Permitted range of calculated volume (mm³)</i>	
		Upper	Lower
Offside	1994399020	2000382217	1988415823
Front	403613803	404824644	402402961.6
Nearside	667058348	669059523	665057173
total	3065071171	3074266385	3055875957

¹ The full 3-D model is available in .stp format on the ECE website at <https://wiki.unece.org/display/trans/Generic+Information+IWG+VRU-Proxi>.