



Economic and Social Council

Distr.: General
8 April 2022

Original: English

Economic Commission for Europe

Inland Transport Committee

World Forum for Harmonization of Vehicle Regulations

187th session

Geneva, 21-24 June 2022

Item 14.2.1. of the provisional agenda

**Consideration and vote by AC.3 of draft UN GTRs
and/or draft amendments to established UN GTRs, if any:
Proposal for amendments to a UN GTR**

Proposal for a technical report on the development of Amendment 5 to UN GTR No. 2 (Measurement procedure for two- and three-wheeled vehicles equipped with a positive or compression ignition engine with regard to the emissions of gaseous pollutants, CO₂ emissions and fuel consumption)

Submitted by the Working Party on Pollution and Energy*

The text reproduced below was discussed by the Working Party on Pollution and Energy (GRPE) at its eighty-fifth session (ECE/TRANS/WP.29/GRPE/85, para. 50). It is a technical report accompanying the proposal for Amendment 5 to UN GTR No. 2 (ECE/TRANS/WP.29/2022/108). It is submitted to the World Forum for Harmonization of Vehicle Regulations (WP.29) and to the Executive Committee (AC.3) of the 1998 Agreement for consideration at their June 2022 sessions.

* In accordance with the programme of work of the Inland Transport Committee for 2022 as outlined in proposed programme budget for 2022 (A/76/6 (part V sect. 20) para 20.76), the World Forum will develop, harmonize and update UN Regulations in order to enhance the performance of vehicles. The present document is submitted in conformity with that mandate.



Technical report on the development of Amendment 5 to UN GTR No. 2 on the measurement procedure for two- and three-wheeled vehicles equipped with a positive or compression ignition engine with regard to the emissions of gaseous pollutants, CO₂ emissions and fuel consumption

I. Mandate

1. Amendment 5 to global technical regulation (GTR) No. 2 was developed by the Informal Working Group (IWG) on Environmental and Propulsion Performance Requirements of L-category vehicles (EPPR). The Executive Committee (AC.3) of the 1998 Agreement adopted the authorisation to develop amendments to UN Global Technical Regulation (UN GTR) No. 2 at its 45th session (12 November 2015) (ECE/TRANS/WP.29/AC.3/36/Rev.1).

II. Objectives

2. The main objective of the above authorization is to develop requirements and/or test procedures under the 1998 Agreement and to create synergies with the 1958 Agreement UN Regulations. Where possible, to develop common requirements in the form of one or more UN Regulations and one or more UN GTRs, as well as associated amendments and/or supplements.

3. Such objective started from the harmonization of the test procedures for two-wheeled vehicles equipped with conventional combustion engine technology, but also included three-wheeled vehicles and other propulsion types in subsequent stages of work.

4. The scope of discussions does not cover light four-wheeled vehicles on emission related UN GTRs.

III. Technical rationale and justification

A. Introduction

5. The industry producing two- and three-wheeled vehicles is a global one, with companies selling their products in many different countries. The Contracting Parties to the 1998 Agreement have all determined that work should be undertaken to address emissions from two-wheeled vehicles as a way to help improve air quality internationally.

6. This UN GTR covers three main environmental verification test type to verify and validate the environmental performance of a wide range of vehicle types with two- and three-wheels.

7. The aim of this UN GTR is to provide measures to strengthen the world-harmonization of two- and three-wheeled vehicle approval and certification legislation, in order to improve the cost effectiveness of environmental performance testing, remove trade barriers, reduce the overall complexity of global legislation, remove potential areas of conflict or opposing requirements and improve the air quality.

8. The first step in this process in 2004 was to establish the certification procedure for motorcycle exhaust emissions in a harmonized UN GTR No. 2. The UN GTR No. 2 Revision 1 extends the scope to all two- wheeled vehicles, updates the testing methodology for technical progress and sets out requirements to measure the energy efficiency of different types of propulsion units fitted to two-wheeled vehicles. The test procedures were developed so that they would be:

- (a) representative of world-wide on-road vehicle operation;

- (b) able to provide an internationally harmonized set of environmental tests to ensure efficient and practicable controls of on-road emissions over the normal life of a vehicle;
- (c) corresponding to state-of-the-art testing, sampling and measurement technology in the area of environmental performance testing of two- wheeled vehicles;
- (d) applicable in practice to existing and foreseeable future exhaust emissions abatement technologies;
- (e) applicable in practice to existing and foreseeable future powertrain technologies;
- (f) capable of providing a reliable ranking of exhaust emission levels from different engine types;
- (g) include adequate provisions to prevent test cycle-bypass.

9. Amendment 5 to UN GTR No. 2 covers three Test Types related to tailpipe emissions:

1. Test Type I: Tailpipe emissions after cold start

10. To monitor the gaseous pollutant emissions a vehicle produces when in general use, Test Type I defines a test procedure in a cold start and performing an appropriate driving cycle in a chassis dynamometer which has been designed for that class of vehicle, while taking into consideration the requirements of test repeatability and reproducibility.

2. Test Type II: Tailpipe emissions at idle (PI engine) and free acceleration test (CI engine)

11. To test low idle and high idle emissions referred to in road worthiness testing, Test Type II defines a test procedure at two idle engine speeds for vehicles equipped with PI engines to measure the emissions of CO and HC and a test procedure at free acceleration for vehicles equipped with CI engines to measure opacity which is indirectly representative of particulate matter emissions for CI vehicles.

3. Test Type VII: Energy efficiency, i.e. CO₂ emissions and fuel consumption

12. To provide information required by consumers to judge the energy efficiency and running costs and practicality of a vehicle, Test Type VII measures for publication and inclusion in vehicle literature, the energy efficiency with respect to CO₂ emissions and fuel consumption.

13. The base UN GTR No. 2 builds on the work of the WMTC Informal Working Group (IWG), its deliberations and conclusions, provided in the group's Technical Report (ECE/TRANS/180/Add.2/Appendix 1) which produced its last amendment on the base UN GTR in 2011. Amendment 5 to UN GTR No. 2 is based on the work of the IWG on EPPR, which held its first meeting during the 65th GRPE in January 2013 sponsored by the European Commission (EC).

B. Procedural background

14. The original work on the base UN GTR No. 2 started in May 2000 with the establishment of the WMTC Informal Working Group. At the UNECE Working Party on Pollution and Energy (GRPE) 45th session in January 2003, a formal proposal by Germany for the establishment of a UN GTR was approved for presentation to the Executive Committee for the 1998 Agreement (AC.3). At its session on 13 November 2003, the proposal from Germany was also approved as a UN GTR project by AC.3.

15. The base UN GTR No. 2 was approved by AC.3 in June 2005. Amendment 1 to the base UN GTR No. 2 was approved by AC.3 in November 2007. The draft text of Amendment 2 to UN GTR No. 2 on the introduction of performance requirements (limit values for

pollutant emissions for vehicles fitted with gasoline engines) was approved by GRPE in January 2011, subject to final decisions concerning the format of the text by AC.3.

16. At its April 2006 meeting held in Pune (India), the informal working group WMTC/FEG agreed to prepare new test cycle proposals and a new vehicle classification for draft amendments to the UN GTR in order to suit low-powered vehicles, such as commonly used in India and China.

17. A small WMTC Task Force, coordinated by the International Motorcycle Manufacturers Association (IMMA), was set up to prepare a proposal on the test cycle(s) and any new classification that might be necessary to achieve this objective. The Task Force was attended by India, Italy, Japan, Germany, the EC and IMMA. Task Force meetings were held in August and October 2006.

18. At its November 2006 meeting held in Ann Arbor (United States of America), WMTC/FEG agreed to a modified version of one of the WMTC Task Force proposals and forwarded it to WMTC Informal Group in January 2007 where it was approved for submission to GRPE.

19. The intention of setting up the group was put forward by the EU and announced during the 63rd and 64th meetings of the GRPE in January and June 2012 and in the 157th session of the WP.29 in June 2012.

20. With the mandate (informal document: WP.29-158-15) accepted at the 158th session of the WP.29 (13-16th November 2012) to establish the IWG on EPPR under the GRPE. At the GRPE 79th session in 2019, a formal proposal drafted by the IWG on EPPR for Amendment 4 of this UN GTR was tabled for adoption by the Executive Committee for the 1998 Agreement (AC.3).

21. On-going developments of test types and procedures and global discussion on harmonization have resulted in the technical requirements contained within this UN GTR. The final text of the UN GTR is presented in Part II of the GTR working document.

C. Regulations and international voluntary standards referenced

1. Technical references in the development of Amendment 5 to UN GTR No. 2

22. For the development of Amendment 5 to UN GTR No. 2, the following regulations contained relevant applications of exhaust emissions requirements for two- and three-wheeled vehicles which were available for technical reference:

(a) UNECE:

UN Regulation No. 40, 01 series of amendments (Uniform provisions concerning the approval of motorcycles equipped with a positive-ignition engine with regard to the emission of gaseous pollutants by the engine).

(b) China:

- (i) GB 14622-2016 "Limits and measurement methods for emissions from motorcycles (CHINA IV);
- (ii) GB 18176-2016 "Limits and measurement methods for emissions from mopeds (CHINA IV).

(c) EU:

- (i) Regulation (EU) No 168/2013 adopted in the course of 2013, amended by Regulations (EU) 2019/129 and Regulation (EU) 2020/1694, as well as the delegated act on environmental and propulsion unit performance requirements.
- (ii) Regulation (EU) No 134/2014 (REPPR), amended by Regulations (EU) 2016/1824 and Regulation (EU) 2018/295, setting out technical provisions and environmental performance test procedures.

- (d) India:
 - (i) MoSRT&H/ CMVR/ TAP-115/116, Central Motor Vehicle Rule No. 115 and AIS 137 Part 1;
 - (ii) Government of India Gazette Notifications: GSR 889 (E) dt. 19.09.2016 and GSR 881 (E) 26.11.2019
- (e) Japan:
 - (i) Road vehicle Act, Article 41 "Systems and Devices of Motor Vehicles";
 - (ii) Safety Regulations for Road Vehicles, Article 31 "Emission Control Devices";
- (f) United States of America:
 - Title 40 U.S. Code of Federal Regulations (CFR) Part 86 Subpart E & F;
- (g) ISO standards:
 - (i) ISO 11486 (Motorcycles - Chassis dynamometer setting method);
 - (ii) ISO 6460 (gas sampling and fuel consumption);
 - (iii) ISO 4106 (Motorcycles -- Engine test code -- Net power).

23. Most of these Regulations had been in existence for many years and the methods of measurement varied significantly. The technical experts were familiar with these requirements and discussed them in their working sessions. The IWG on EPPR therefore considered that to be able to determine a two- wheeled vehicle's real impact on the environment, in terms of its exhaust pollutant emissions and energy efficiency, the test procedure and consequently the UN GTR No. 2 needs to represent modern, real-world vehicle operation.

IV. Development of Amendment 5

24. Following the above mandate (ECE/TRANS/WP.29/AC.3/36/Rev.1) and the agreed IWG terms of reference (GRPE-81-23r1e.pdf), the IWG on EPPR has proceeded with an entire revision of UN GTR No. 2 in Amendment 5, in order:

- (a) To correct editorial typographical and formatting mistakes;
- (b) To align the UN GTR to the work done by the IWG on Worldwide harmonized Light Vehicles Test Procedure (WLTP), if considered advantageous, to ensure harmonization and to avoid any duplication of effort;
- (c) To update the UN GTR for technical progress, as necessary;
- (d) To extend the scope to three-wheeled vehicles, with the exception of the low-powered Indian specific ones;
- (e) To add the definition of twinned wheeled vehicles for clarification;
- (f) To extend the scope to alternative fuels (notably CNG and LPG).

25. While the text of the UN GTR No. 2 was mainly kept aligned with Euro 5 as agreed at the beginning of the revision process, the changes explained here below were agreed in Amendment 5 compared to Amendment 4 of such UN GTR.

A. General corrections

1. Motorcycle

26. The terminology "motorcycles" and "mopeds" was removed to the extent possible, as being specific of a certain region (EU), while specific classes of vehicles have been defined in this UN GTR (0,1,2,3).

2. Reference fuels

27. Correction of a mistake:

Principal (Euro5)

Table A4.App 2/1 : Japan E0

Table A4.App 2/3 : Japan E0 100

Table A4.App 2/4 : EU E5

Table A4.App 2/6 : EU B5

Alt-A (India BS-4)

Table A4.App 2/2 ; EU E0

Alt-B(Euro-4)

Table A4.App 2/4 : EU E5

Alt-C(Euro-3)

Table A4.App 2/4 : EU E5

3. Administrative Provisions

28. Since Type Approval is not used in all regions, “certification” was used instead of “type approval” and “responsible authorities” instead of “approval authorities”.

B. Alignment with WLTP

1. Introduction

29. A general alignment with WLTP was proposed by IMMA at EPPR-39 (October 2020): EPPR-39-02 and EPPR 39-03

(a) To align with latest version of Amendment 6 to UN GTR No. 15 on WLTP;

(b) To resolve/avoid interpretation issues.

It was supported by Japan at EPPR-39, by EC at EPPR-40 (December 2020) and agreed.

2. Flowchart

30. In EPPR-43-05 (March 2021), IMMA proposed to substitute the flowchart Figure A1/7 in Amendment 4 with the flowchart Figure A6/1 from the UN GTR No. 15 on WLTP (ECE/TRANS/WP29/2020/127), in order to align it with WLTP.

Old figure in Amendment 4:

Figure A1/7

Flowchart for the number of Test Type I

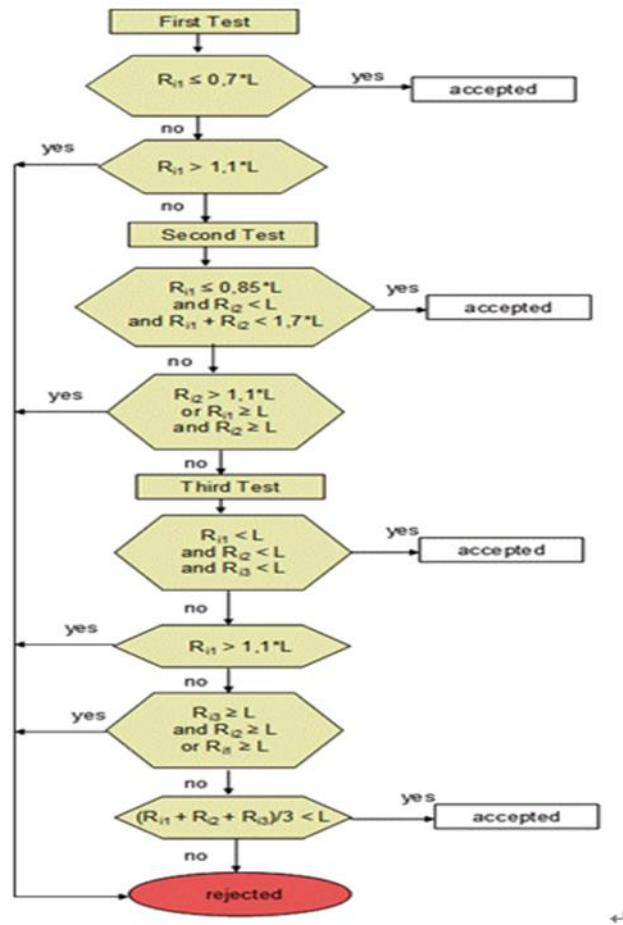

Proposed figure for Amendment 5:

Figure A1/7

Flowchart for the number of Test Type I

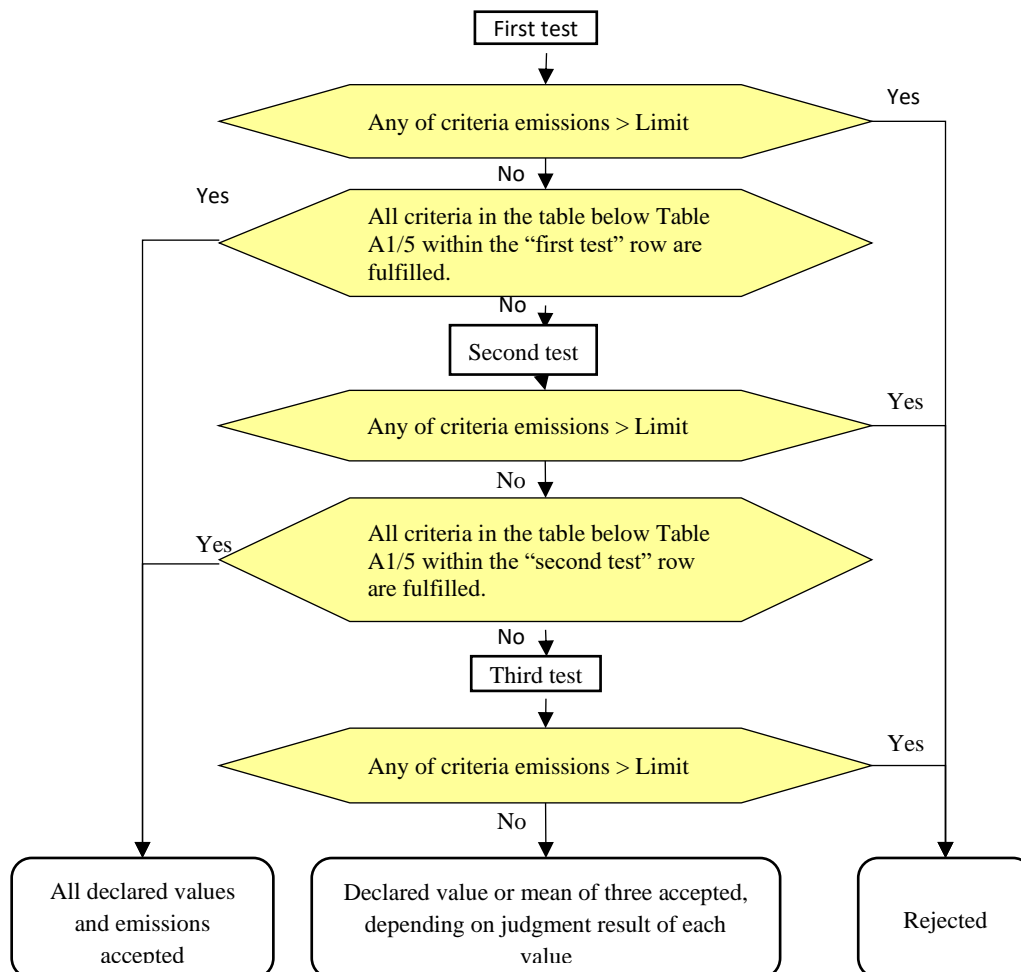

31. The main difference with the previous flowchart was the correction of the references: from table A5/1 to A6/2.

India/ Kumbhar observed that “declared value or mean of three” was meant for CO₂ and pollutant emissions in UN GTR No. 15, but that this interpretation was not applicable to UN GTR No. 2, not addressing CO₂.

IMMA committed to review the flowchart according to this comment.

EPPR-46 (June 2021), the IWG on EPPR agreed to re-check the above flowchart in EPPR-46-06, notably the need or not to have the third test for pollutant emissions. Counterproposals to be sent in written form, in good time to be evaluated by the IWG on EPPR, before following meeting of the IWG on EPPR.

In lack of any counterproposal agreed by the IWG on EPPR before the deadline of 19 October, the flowchart in EPPR-46-06 (which is taken from GRPE-83-26-rev.1 for this point) will be submitted to GRPE.

In EPPR-47 (July 2021), The secretariat of the IWG on EPPR invited the IWG to express position on the flowchart Fig. A1/7 in EPPR-46-06, notably on the need or not to have the third test for pollutant emissions.

WLTP required it for CO₂ but not for pollutant emissions.

China had requested at last EPPR-46 session whether the third test was needed for pollutant emissions.

Chair expressed preference for keeping the flowchart as proposed in EPPR-46-06.

Chair proposed to accept the flowchart as in EPPR-46-06 in lack of any counterproposal, inviting the IWG on EPPR to raise any potential counterproposal in good time before submission of the formal document to GRPE in October.

Japan, after evaluating the correspondent WLTP-flowchart, confirmed their stance to keep this flowchart unchanged.

China recalled their request at last EPPR-46 session to check whether the third test was needed for pollutant emissions.

In lack of counter-proposals, the flowchart in EPPR-46-06 remained as in Figure A1/7, noting that the third test applied only to pollutant emissions in UN GTR No. 2.

3. Mref

32. The IWG on EPPR agreed on the need to correct m_{ref} of 199 kg into m_k of 199 kg in Annex 4, Table A4.App13/2 of Amendment 4 to UN GTR No. 2, as in Amendment 6 to UN GTR No. 15 (WLTP).

4. Other points

33. In Table A1/6 Instrument calibration intervals, NO_2 was changed into NO_x , to align with WLTP; 1.225 kPa was changed into 1.25kPa, to align with WLTP; paragraph 3.4.3.8.1 and information about bag material were added, to align with WLTP

For dilution air and dilute exhaust mixture the collection bags shall be of sufficient capacity not to impede normal sample flow and shall not change the nature of the pollutants concerned.

The bag material shall be such as to affect neither the measurements themselves nor the chemical composition of the gas samples by more than ± 2 per cent after 30 minutes (e.g., laminated polyethylene/polyamide films, or fluorinated polyhydrocarbons).

34. In paragraph 4.2.3.4.5., some parameters were added to align with WLTP:

“From the trace of the linearization curve and the linearization points, it is possible to verify that the calibration has been carried out correctly. The different characteristic parameters of the analyser shall be indicated, particularly:

- (a) Analyser and gas component;
- (b) Range;
- (c) Date of the linearization.”

35. Paragraph 4.2.3.6.1., text was added to align with Amendment 6 to UN GTR No. 15 on WLTP:

“

The following pure gases shall be available, if necessary, for calibration and operation:

At the request of the Contracting Party, in the case that gases within the following tolerance of the stated value are not available in the region, a gas with a wider, but the tightest, tolerance available in the region may be used.

Purified hydrogen (and mixture containing helium or nitrogen): (purity ≤ 1 ppm C1, ≤ 400 ppm CO_2 ; hydrogen content between 39 and 41 per cent volume);”

36. Analysis of the samples: paragraph 4.2.7.2., 20 minutes was changed into 30 minutes, to align with WLTP.

37. Emissions (diluted gas) data monitoring: paragraph 4.2.7.2., “shall” was replaced by “may”, to align with WLTP.

In WLTP, no procedure is specified:

“ 2.9. Gaseous sampling

Gaseous samples shall be collected in bags and the compounds analysed at the end of the test or a test phase, or the compounds may be analysed continuously and integrated over the cycle.”

US 40 CFR paragraph 86.537-90 reads:

“Continuous monitoring of exhaust emissions will not normally be allowed. Specific written approval must be obtained from the Administrator for continuous monitoring of exhaust emissions.”

38. Analysis of the samples: paragraph 5.1.1.1., 20 minutes was changed into 30 minutes, to align with WLTP.

Paragraph 5.1.1.4.3., B5 and B7 specifications were added, to align with WLTP.

Paragraph 5.1.1.4.9, B0 and B7 specifications were added, to align with WLTP.

In Annex 3 paragraph 2.2.4., B5 and B7 specifications were added, to align with WLTP.

In Annex 3 paragraph 1.4.3.6., B0 specifications were added, to align with WLTP.

C. Technical corrections

1. Masses considered when setting the chassis dynamometer.

39. The masses to be considered when setting the chassis dynamometer are different between Euro 5 and UN GTR No. 2 because of an error in Euro 5, as EC explained in [EPPR-40-01](#).

When setting the dynamometer, Euro 5 uses m_k = kerb mass without the driver mass, while UN GTR No. 2 Amendment 4 used m_{ref} , which includes driver mass, in alignment with ISO11486: $m_{ref} = m_k + 75$ kg.

At EPPR-40 (Dec. 2020), EC explained that the masses indicated in UN GTR No. 2 were correct, while Regulation (EU) No. 134/2014 on Euro 5 contained an error explained in details in the presentation EPPR-40-01 (EC). The IWG on EPPR agreed to continue mainly using m_k , as long as practicable.

Note on ISO11486 “Motorcycles – Methods for setting running resistance on a chassis dynamometer” in order to determine the guidance from this document wrt choosing mass for the running resistance table.

The document states:

“10 Chassis dynamometer settings using the running resistance table.

10.1 Applicability

The chassis dynamometer can be set by the use of the running resistance table instead of the running resistance force obtained by the coast-down method. In this table method, the chassis dynamometer shall be set by the reference mass regardless of particular motorcycle characteristics.”

ISO11486, Section 4 Symbols states:

“ m_{ref} = kerb mass of the motorcycle increased by a uniform figure of 75kg, which represents the mass of a rider,”

2. Twinned wheeled vehicles

40. Two-wheeled vehicles with twinned wheels were already included in UN GTR No. 2 Amendment 4, as IMMA confirmed at EPPR-41 (January 2021).

However, since the definition of twinned-wheels was missing, in order to avoid any potential misunderstanding, IMMA made a presentation to clarify the difference between “twinned wheels” and “three-wheeled vehicles” in EPPR-42, Feb 2021: see EPPR-42-06r1.

In EPPR-43-02, IMMA proposed to add a definition of “twinned-wheels”, in order to align Amendment.5 with Regulation (EU) No. 134/2014.

In EPPR-43-05, IMMA proposed to add a further clarification on the need for a "twinned wheels-" configuration to tilt when turning. It was agreed in principle, while changing the wording into "two-wheeled mopeds" and "two-wheeled motorcycles".

The updated proposal on twinned wheels was reflected in line 15 of EPPR-43-10:

“‘*twinned wheels*’ means two wheels mounted on the same axle which are considered to be one wheel, whereby the distance between the centres of their areas of contact with the ground is equal to or less than 460 mm.

For two-wheeled moped and two-wheeled motorcycles, in the case the vehicle is equipped with a "twinned wheels-" configuration, the full vehicle structure or part of the vehicle structure shall tilt when turning.”

The above text was retained in EPPR-44-03 and in the formal document (GRPE/2022/6).

3. Three-wheeled vehicles (3w)

41. In October 2020, during EPPR-39, IMMA announced their intention to propose inclusion of three-wheeled vehicles into Amendment 5 to UN GTR No. 2 three-wheeled vehicles had not been included in Amendment 4 for the sake of simplification necessary to cope with the pressure put by some Countries to finalize the work on that amendment in a short time period, in order to comply to national obligations. UN GTR No. 2, however, had historically contained three-wheeled vehicles into their scope and thus IMMA propose to re-add 3w into the UN GTR No. 2 scope.

Same session, EPA supported it.

During EPPR-41 (January 2021), IWG on EPPR agreed to extend scope to three-wheelers. Subsequently, it was decided to exempt India low-powered three-wheelers; see below.

4. India-specific three-wheeled vehicles

42. In EPPR-41-02 (January 2021), India initially proposed to add the low-powered three-wheeled vehicles typical of the Indian market in the scope.

It was however noted that, because of their low power-to-mass-ratio, the max-speed and acceleration of Indian three-wheeled vehicles is much less than that required by the applicable WMTC cycle.

In terms of emission regulations, this category of vehicles in India is treated separately from other L-category vehicles, because of their unique operating conditions of usage.

43. In India, this type of vehicle is addressed by specific norms for exhaust emissions being in force since April 2020 in Bharat Stage VI (BS VI) on the basis of the Indian Driving Cycle (IDC), which is different from the test cycle in UN GTR No. 2.

44. Since India could not yet clarify whether this type of vehicles needed a dedicated cycles also in UN GTR No. 2, at EPPR-42 (February 2021) India supported the principle to include in Amendment 5 to UN GTR No. 2 the type of three-wheeled vehicles already included in Euro 5, but to exempt for the time being the low-powered vehicles typical of the Indian market, while possibly considering them in future amendments. The IWG on EPPR agreed to add a note of clarification after paragraph 1.1., clarifying that vehicles with $PMR \leq 22W/kg$ and max. design speed $\leq 70 km/h$ were put in abeyance in Amd. 5.

5. Alternative fuels

45. In EPPR-41-02 (January 2021), India proposed to include gas-fuelled three-wheeled vehicles in the scope of UN GTR No. 2, notably CNG- and LPG-fuelled three-wheeled vehicles, and to make following changes in order to get there:

“To add limp-home fuel system in UN GTR No. 2 for gas-fuelled three-wheeled vehicles.

To exempt limp fuel system (gasoline mode) for emission test.

To include new definitions relevant to gas-fuelled vehicles (mono-fuelled vehicle, mono-fuelled gas vehicle, limp home)

To include CNG and LPG reference fuels specifications.”

46. India proposed to extend scope to gaseous-fuelled vehicles – not only 3w - notably to add CNG and LPG vehicles. India expressed preference to include them in Amendment 5 but also flexibility on the possibility to consider to add them in a sub-sequent amendment.

At EPPR-44 (April 2021), the IWG on EPPR decided to add alternative fuels as proposed by India in EPPR-43-08.

6. Limp-home fuel system (gasoline) definition

47. During EPPR-42, in February 2021, as requested by Chair, India provided following explanation on “limp-home fuel system (gasoline)” which is not mandatory.

48. Limp-home fuel system (gasoline) may be used on mono-fuel vehicle designed for running on LPG or NG / bio-methane fuels. This system consists of an auxiliary gasoline fuel tank with limited fuel capacity and is intended use for vehicle running in emergency purposes. This would allow the rider to drive vehicle to the next gas-fuel pump/station in emergency cases.

For such system, the fuel tank capacity shall not exceed two litres in the case of two wheeled motorcycles and motorcycles with sidecar, and not exceed three litres in the case of three-wheeled vehicles as per UN GTR No. 17 and UN GTR No. 18, so that the vehicle cannot run on gasoline in conditions other than emergency ones.

The performance requirements/emissions of Type I, II and VII should not be measured when vehicle is running on gasoline mode.

7. WMTC for sub-class 0-2

49. The IWG on EPPR clarified that following parts of WMTC apply to sub-class 0-2:

Sub-class 0-1	part 1, RST25 in cold condition, followed by part 1, RST25 in warm condition
Sub-class 0-2	part 1, reduced vehicle speed in cold condition, followed by part 1, reduced vehicle speed in warm condition, if maximum design speed is 50 km/h part 1, RST45 in cold condition, followed by part 1, RST45 in warm condition, if maximum design speed is 45 km/h
Class 1	part 1, reduced vehicle speed in cold condition, followed by part 1, reduced vehicle speed in warm condition

50. In other words, the IWG on EPPR clarified that vehicles of sub-class 0-2 with max. vehicle design speed of 50 km/h will follow the same WMTC-trace as class 1. This conclusion was clearly added to the specifications already present in Amendment 4.

51. It was a long discussion, history follows.

As in Amendment 4, sub-class 0-2 was defined as: "Engine Capacity $\leq 50\text{cm}^3$ and $25\text{km/h} < v_{\text{max}} \leq 50\text{km/h}$ ". This class was defined in the same way in UN GTR No. 2, China and ISO standards. March 2021, EPPR-43-03-r1 was presented by Ms. Wang/China, proposing:

- (a) To clarify applicable parts of WMTC for sub-class 0-2;
- (b) To change the description under the tables of cycles accordingly.

52. Problem: For class 0-2, UN GTR No. 2 has defined a max. design speed of 50 km/h. However, Table A1/1 only describes max. test speed 45km/h – a case applying to vehicles whose max. design speed does not exceed 45km/h. This might create confusion if not well clarified.

53. In order to avoid misinterpretation, China proposed to split the description of the test for 0-2 in two cases:

54. The first case applying to the “regular” 0-2 vehicles, whose max. design speed is 50 km/h. China proposed to apply the same test cycle as cat. 1 in this case. This case was not depicted in former Table A1/1 and Table A1/2, later respectively Figure A4.App12/5 and A4.App12/6.

55. The second case applying to vehicles whose max. design speed is 45 km/h. China proposed to leave the test unchanged in this case; i.e. The test speed would be truncated at 45 km/h. This case was depicted in Table A1/1.

When the above proposal was approved, it was also agreed to change the footnote under table A1/1 accordingly:

56. The 2nd part of the footnote about 50 km/h was deleted, since not correct.

The 1st part of the footnote was improved in order to describe better the blue and the red line about RST45.

57. At EPPR-43, the IWG on EPPR also confirmed how to proceed in case the acceleration capability of the vehicle was not sufficient to carry out the acceleration phases or in case the max design speed of the vehicle was lower than the prescribed cruising speed. In this case, it was confirmed that Annex 1 of Amendment 4 to UN GTR No. 2 was based upon the procedure set out in Regulation (EU) No.134/2014 ANNEX II (EURO 5).

58. At EPPR-44 (April 2021), the Chair asked to evaluate also a different proposal from his side:

In case of vehicle with maximum design speed of 50km/h, the vehicle shall be driven on WMTC up to maximum speed of 45km/h. EPA supported the Chair and proposed to express his intentions with a different wording; see EPPR-44-07.

59. The IWG on EPPR was invited to evaluate the above options and EPPR-44-07 for consideration on the following day.

The secretariat of the IWG on EPPR recalled the difference stances presented on previous day and invited the IWG on EPPR to clarify not only the note but also the understanding of 0-2 test cycle.

60. Chair showed that the traces for 0-2 had been assigned a max. test speed of 45 km/h. He proposed to increase the max. test speed from 45 to 50 km/h, increasing the test speed in Table A4.App12/30 as follows:

199s	43.3 km/h
200s	45 km/h
201s	50 km/h

61. Chair wondered, however, whether it is technically feasible for these types of vehicles to have an acceleration of 1.86 m/s² (almost 2m/s²) for going from 45 to 50 km/h in 1s, in contrast with the acceleration of 0.47 m/s² for going from 43.3 to 45 km/h, as it would be about 4 times faster.

62. MECA proposed to make this speed increase in a more gradual way, as follows:

199s	43.3 km/h
200s	45 km/h
201s	46 km/h
202s	47 km/h
203s	48 km/h
204s	49 km/h
205s	50 km/h

63. AECC asked to clarify whether a change in the WMTC cycles would also imply a similar change of the European cycle, which would be inherently linked to significant work.
64. In order to avoid changing the European cycles, Chair proposed to keep the trace unchanged for vehicle with max. design speed of 45km/h (as in EU), but to change the trace for vehicles with max. design speed of 50 km/h (mainly outside EU). Of course, he deemed it easier to leave the trace unchanged.
65. Chair further explained his idea to lift up the plateau from 45 to 50 km/h; see Figure A4.App12/5
66. China re-presented their former proposal EPPR-43-03-rev1, requesting:
- (a) To change the description of WMTC for 0-2, notably to split the description of the test for 0-2 in two cases:
- The first case applying to the “regular” 0-2 vehicles, whose max. design speed is 50 km/h. China proposed to apply the same test cycle as cat. 1 in this case
- The second case applying to “European” 0-2 vehicles whose max. design speed is 45 km/h. China proposed to leave the test unchanged in this case; i.e. the test speed would be truncated at 45 km/h. This case was depicted in Table A1/1.
- (b) To clarify the note.
67. Chair expressed some concerns that, changing the trace would imply considerable changes in the text of the UN GTR but these concerns were lifted after some discussion.
68. After an extensive exchange between Chair and China, the following agreement was found by the IWG on EPPR.
69. The Chinese proposal EPPR-43-03-rev.1 was agreed with inclusion of a sentence for clarification, as shown in Table A1/1.
70. It was agreed to delete the last part of the note in Figure A4.App12/5 and /6.

D. Standards

1. Chinese standards

71. At EPPR-40 (December 2020), China asked to see their standards reflected in the list of standards considered during the development of UN GTRs, in particular UN GTR No. 2, without the need to re-open any technical discussion. See EPPR-40-05.
72. As clarified by the EPPR Chair and agreed by the IWG on EPPR, the Chinese standards were added into the “Part I (Rationale)” of such GTR and in paragraph C.1 of the current Technical Report.
-