

Informal meeting on Code of Practice for Packing of Cargo Transport Units

at the request of the United Nations Economic Commission for Europe Working Party on Intermodal Transport and Logistics

Geneva and virtual, 17-18 March 2022

Blocking and bracing material and arrangements

Submitted by ETS Consulting

This document proposes changes to Annex 7, clause 2 on Packing and securing material and clause 4 on Securing of cargo in CTUs.

The following comments were received from packing experts regarding the existing CTU Code wording:

- The principle of securing the load against the corner posts of the container to prevent longitudinal displacements, as shown in 2.3.4, figure 7.6, cannot be applied to the container structures currently used. Therefore, this clause should be reformulated.
- The example of securing a load to the corner posts of the container door opening shown in figure 7.32 is not correct, as the corner posts do not protrude beyond the side walls of the container.

In view of the above points, text changes are proposed to clauses 2.3.4 and 2.3.5 and to 4.1.3, 4.1.7 and 4.2.4. These changes are marked through track changes.

This document further proposes consequential changes, which concern addition of definitions to Chapter 2 of the CTU Code and adding a new appendix on fixings and fastenings.

Proposed changes:

Clause 2 on Packing and securing:

2.3.4 Transverse battens in a CTU, intended to restrain a block of packages in front of the door or at intermediate positions within the CTU, should be sufficiently dimensioned in their cross section, in order to withstand the expected longitudinal forces from the cargo (see figure 7.6). ~~The ends of such battens may be forced into solid corrugations of the side walls of the CTU. However, preference should be given to brace them against the frame structure, such as bottom or top rails or corner posts.~~ Such battens act as beams, which are fixed at their ends and loaded homogeneously over their entire length of about 2.4 metres. Their bending strength is decisive for the force that can be resisted. The required number of such battens together with their dimensions may be identified by calculations, which is shown in appendix 4 to this annex.

Wherever possible such battens should be braced against the frame structure, such as bottom or top rails or corner posts. While it is recognised that this type of bracing is not possible on all types of CTU, any that has a shoring slot built into the rear frame can accommodate this bracing technique. Alternative bracing can be achieved by forcing the battens into the solid corrugations of the side walls of the CTU, employing a modular lashing system as described in subsection 2.4.19 of this annex or the use of friction increasing material.

2.3.5 Blocking that is secured using mechanical fixings by nailed on scantlings bedding or spreader beams should be used for minor securing demands only. The different types of fixing will provide a range of shear strengths d Depending on the type, configuration and size of the fixing nails used (examples of fixings can be found in Appendix X).

For example, the shear strength of ~~such~~ a blocking arrangement secured using nails may be estimated to take up a blocking force between 1 and 4 kN per nail. Nailed on wedges may be favourable for blocking round shapes like pipes. Care should be taken that wedges are cut in a way that the direction of grain supports the shear strength of the wedge. Any such timber battens or wedges should only be nailed to dunnage or timbers placed under the cargo. Wooden floors of closed CTUs are generally not suitable for nailing. Nailing to the softwood flooring of flatracks or platforms and open CTUs may be acceptable with the consent of the CTU operator (see figure 7.7).

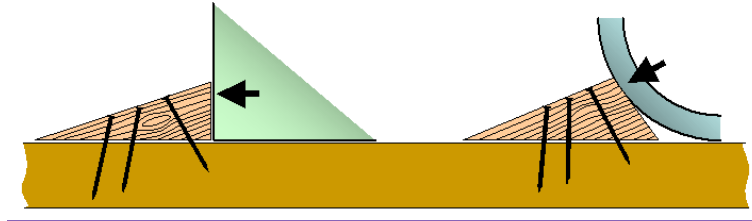

Figure 7.7 Properly cut and nailed wedges

Clause 4 on Securing of cargo in CTUs:

4.1.3 Practical securing of cargo may be approached by three distinguished principles, which may be used individually or combined as appropriate:

- Direct securing is effected by the immediate transfer of forces from the cargo to the CTU by means of blocking, lashings, shores or locking devices (see 4.1.7). The securing capacity is proportional to the MSL of the securing devices;
- Friction securing is achieved by so-called tie-down or top-over lashings which, by their pre-tension, increase the apparent weight of the cargo and thereby the friction to the loading ground and also the tilting stability. The securing effect is proportional to the pretension of the lashings. Anti-slip material in the sliding surfaces considerably increases the effect of such lashings;
- Compacting cargo by bundling, strapping or wrapping is an auxiliary measure of securing that should always be combined with measures of direct securing or friction securing.

4.1.7 Any cargo securing measures should be applied in a manner that does not affect, deform or impair the package or the CTU. Permanent securing equipment incorporated into a CTU should be used whenever possible or necessary. Where this is not possible the following should apply:

4.1.7.1 Blocking should be braced against structurally significant components of the CTU, which may be corner posts (in containers but possibly not road vehicle bodies) and bottom rails.

4.1.7.2 Additional shoring may be made against the boundary side and front walls so long as the forces are distributed by spreader beams as shown in Figures 7.1 and 7.2.

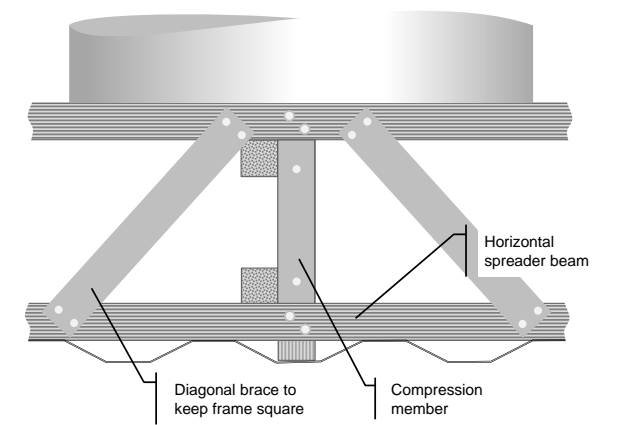

Figure 7.1 Boundary shoring system

Figure 7.2 Horizontal shoring system

4.1.7.3 The CTU doors may be tested to withstand a force equivalent to a percentage of the CTU's payload, however, for cargoes that are liable to move, such as bulk materials (solids and liquids), small hand-packed packaged and pallets with low integral stability, the doors should not be used to constrain the cargo as there is a risk of the cargo falling onto those who open the CTU for inspection or unpacking. In such cases the cargo should be restrained by spring lashing (see Figure 7.43), a modular lashing system (see Figure 7.20) or using shoring bars / rear false bulkhead (see 5.3.4).

4.1.7.4 Cargo should never be secured by blocking, shoring or lashing against the CTU roof except for designs that permit this method of securing.

4.2.4 Critical situations may arise, ~~e.g.e.g.~~, with a fully packed freight container in road transport, where longitudinal securing should be able to withstand an acceleration of 0.8 g. The longitudinal wall resistance factor of 0.4 should be combined with a friction factor of at least 0.4 for satisfying the securing balance. If a balance cannot be satisfied, the mass of cargo should be reduced, or the longitudinal forces transferred to the main structure of the container. The latter can be achieved by intermediate transverse fences of timber battens (see subsection 2.3.4 of this annex) or by other suitable means (see figure 7.32). When bracing against the rear corner frames, vertical timber battens (VB) should be inserted into the shoring slots between the slot bars and the bracing battens (BB) fitted against this. Where required nails or other fixings can be used to stabilise the bracing battens.

Another option is the use of friction increasing material.

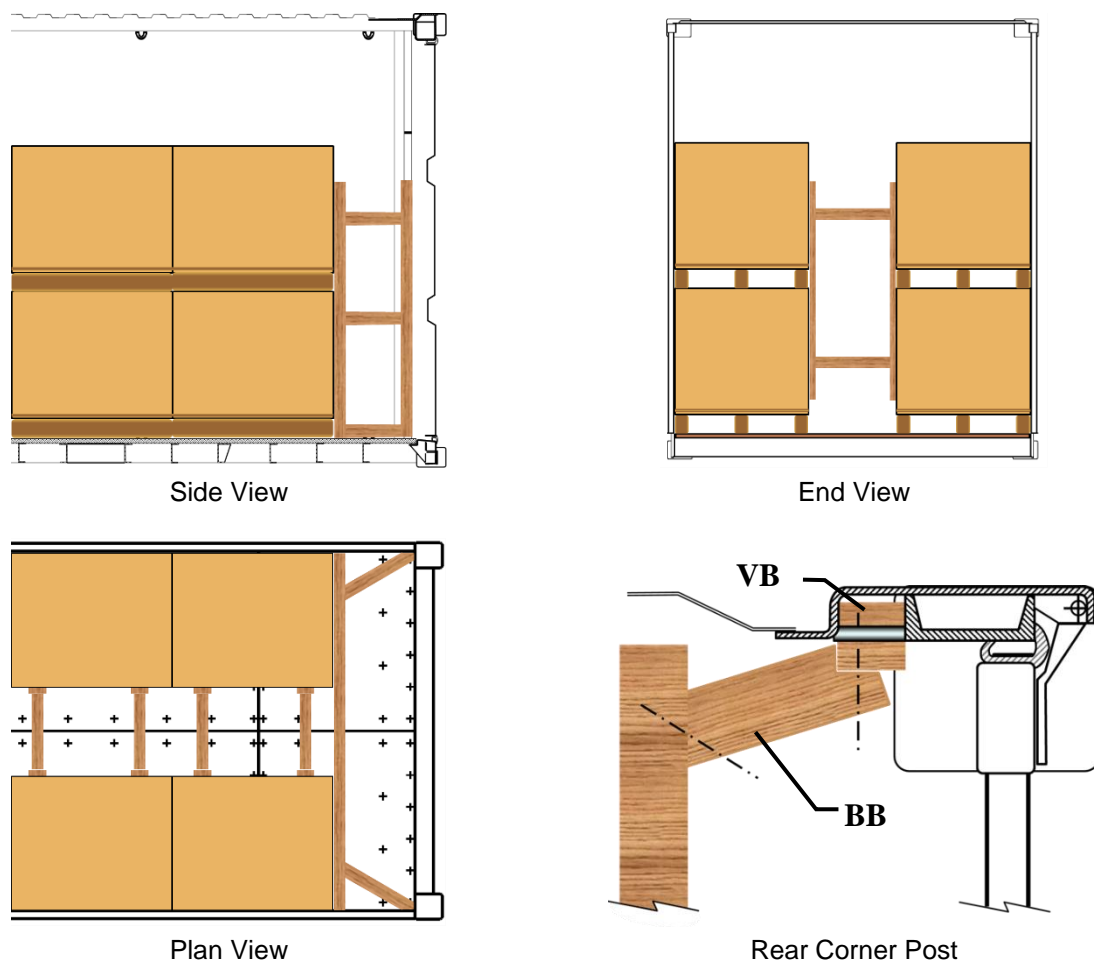

Figure 7.32 Blocking in a strong boundary CTU

|

Consequential changes

1. Add new definitions

• Blocking	To add pieces of wood or other materials for filling horizontal spaces to prevent the cargo from sliding.
• Bracing	To add pieces of wood or other material to prevent the cargo from tipping or rolling.
• Lashing	Flexible material such as webbing, rope or chain placed over or through or attached to securing lugs at or near the top of the cargo, that is used to hold the cargo down onto the CTU deck / floor.
• Shoring	A system of blocking and / or bracing that supports the cargo in its transport position usually consisting of a frame built between the cargo and the boundary of the CTU

Add new appendix

Appendix X Fixings and fastenings

1. Introduction

1.1 The strength, stability, and life of a structure or parts of a structure are dependent to a large extent on the strength, rigidity, and durability of the joints. In conventional frame construction, mechanical fastenings furnish the usual means of joining the structural members as well as any covering materials. The type, size, number, and arrangement of fastenings in conventional construction have commonly been determined by experience, precedent, and the judgment of the individual carpenter, however in a packing operation such experience may not be available, therefore this annex is provided to provide the rudiments of fixing theory.

1.2 Mechanical fastenings can come in a number of formats:

- Bolts
- Dowels
- Machine screws
- Nails
- Screws
- Spiked washers / plates (also known as Tag Washers)
- Spikes
- Staples

1.3 Each of these mechanical fastenings will have its own characteristics and their use will depend on the nature, strength and integrity of the joint to be made. The most common fastening used in fabrication packing framework is the nail due to its ease of availability and use, however in some joints another fastening type would be more properly used.

2. Nailed Joints

2.1 Three principal factors affect the efficiency of a nailed wood joint--the wood, the nail, and the conditions of use. There are, of course, other factors but these are related directly or indirectly to the primary factors.

2.2 Conditions of use

2.2.1 Nails in use are subjected either to withdrawal loads or lateral loads, or a combination of the two. Both withdrawal load and lateral load are affected by the wood, the nail, and the condition of use, but in general any variation in these factors has a more pronounced effect on withdrawal than on lateral load.

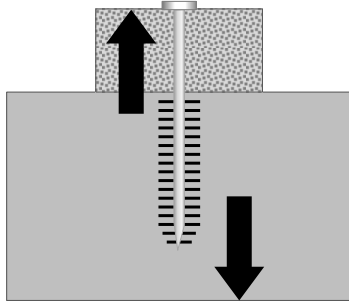

Figure **Error! No text of specified style in document.**..1 Withdrawal loads

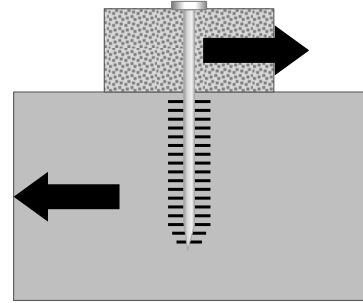

Figure **Error! No text of specified style in document.**..2 Lateral loads

2.2.2 The principal variations in wood are its specific gravity, moisture content, and direction in which the nail is driven with respect to grain. The harder woods hold nails better than softer woods, although harder woods are more difficult to nail and have a greater tendency to split. Nail-holding ability of wood that is not thoroughly dry may vary considerably when the wood dries after the nails are driven.

2.2.3 The resistance to withdrawal and lateral displacement is higher when nails are driven into side grain of wood than when driven into the end grain, and therefore side grain nailing is always preferred.



Figure Error! No text of specified style in document..3 Side grain

Figure Error! No text of specified style in document..4 End grain

2.3 Nail design

2.3.1 There are two principle types of nail, wire nails and cut nails. Below is a table of the more commonly used wire nails:

Type of nail	Head	Shank	Point	Common length [mm]	Common length [in]
Common (Spike)	F	C,S	D	100 - 350	4 - 14
Standard or common	F	C, R, S	D	25 - 150	1 - 6
Box	F, Lf	C, R, S	D	19 - 125	3/4 - 5
Finishing	Bd	C, S	D	25 = 100	1 - 4
Flooring casing and	Cs	C, S	Bt, D	28 - 80	1 1/8 - 3/4
Cladding and	F, O	C, S	D	50 -	2 - 2 1/2

Type of nail	Head	Shank	Point	Common length [mm]	[in]
decking				63	



Figure Error! No text of specified style in document..5 Types of wire nail

Type of head	Abbr	Remarks	
Flat, counter-sink	Fs	For nail concealment; light construction, flooring, and interior trim	
Finishing	Bd	For nail concealment, cabinet work, furniture	
Flat	F	For general construction	
Large flat	Lf	For tear resistance, roofing paper	
Oval	O	For special effects, cladding and decking	

Figure Error! No text of specified style in document..6 Types of wire nail heads



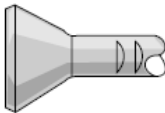
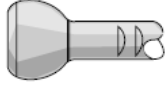
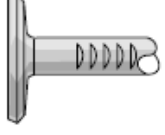
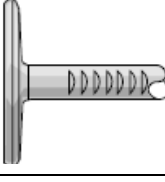
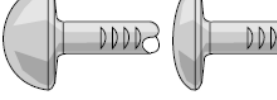

Types of shank	Abbr	Remarks	
Smooth	C	For normal holding power; temporary fastening	
Spiral or helical	S	For greater holding power; permanent fastening	
Ringed	R	For highest holding power; permanent fastener	

Figure Error! No text of specified style in document..7 Types of wire nail shanks

Types of points	Abbr	Remarks	
Diamond	D	For general use, 35° angle;	



length about 1.5 x diameter			
• Blunt diamond	• Bt	• For harder wood species, 45° angle to prevent splitting	• 
• Long diamond	• N	• For fast driving, 25° angle, may tend to split harder species	• 

Figure Error! No text of specified style in document..8 **Types of wire nail points**

2.3.2 Wire nail sizes

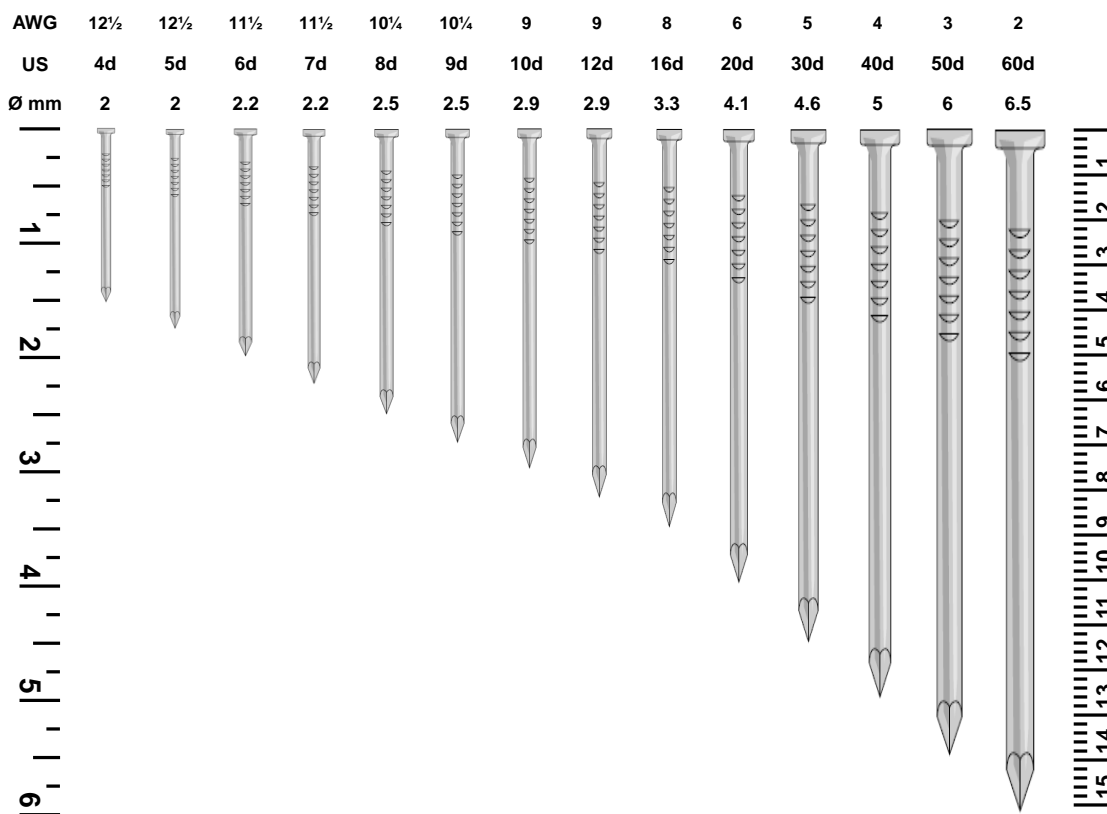

Figure Error! No text of specified style in document..9 Typical wire nail sizes

2.4 Cut nails

2.4.1 Cut nails are cut or sheared from steel plate and may be hardened. They have a wedge shape with a square, blunt point which reduces spalling during penetration into hard materials. During fabrication the shank is tapered by the cutting machine and the nail head is made with a different machine. Cut nails are thick and because they displace more wood fibre, they have greater holding power than standard nails.

2.4.2 Like wire nails, design varies mostly in the length of the shank and the size and shape of the head, which is proportionate to the shank.

Shanks measure from 25 mm to 100mm (1 to 4 in) on up to 200mm (8 in) for post and beam.

Nail heads can be domed, flat or L shaped.



Figure Error! No text of specified style in document..10 Domed head



Figure Error! No text of specified style in document..11 Flat head



Figure Error! No text of specified style in document..12 L shaped

2.4.3 Cut nails are near constant thickness but tapered in width. Aligning the parallel sides of the nail with the wood grain, the square tip shears fibres and the nail then bends fibres

downwards as well as compressing them as it is driven.

- 2.4.4 Cut nails may be clinched (bent at a 90-degree angle after the nail has passed through wood).
- 2.4.5 Machine-cut nails also provide superior grip because they tear through wood fibres instead of splitting the wood. A slight variation on the straight-edged nail is the belly nail that bows out in the centre. As the nail is driven into the wood, the broad middle rips a path that gets closed up around the head as it's pounded in. Its irregular shape keeps it from pulling out.
- 2.5 Nail withdrawal resistance
- 2.5.1 In general, the withdrawal resistance of nails increases with an increase in specific gravity of the wood. Tests with plain-shank nails in several species of wood indicate that the withdrawal resistance varies about as the $2\frac{1}{2}$ power of specific gravity. In other words, an increase in specific gravity of 25 percent is accompanied by a 75 percent increase in withdrawal resistance soon after driving.
- 2.5.2 One of the major improvements in nailed fastenings has been the development of the annular or helically threaded nails, The primary advantage of these nails is that their withdrawal resistance is not appreciably affected by time and moisture changes in the wood. They provide a much more reliable fastening as they are not subject to the variability and reduction in load common to the plain shank nail in many uses.

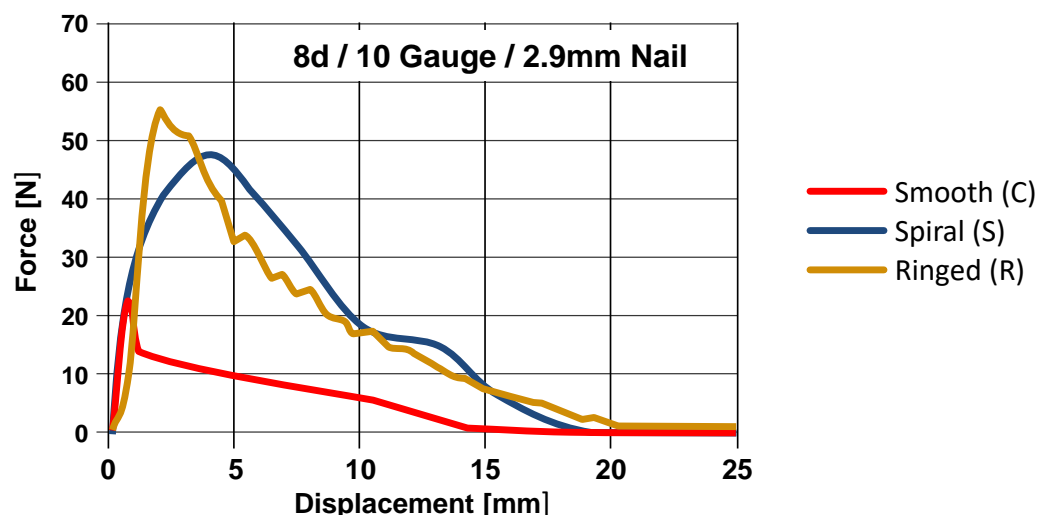

Figure Error! No text of specified style in document..13 Extraction force vs displacement

- 2.5.3 The graph shown in Figure Error! No text of specified style in document..13 displays the relative force required to pull a sample nail driven 25mm into a timber test piece (Spruce – 430 kg/m²). Change the timber to pine and the withdrawal force required will increase from approximately 50N to 80N per 25mm of penetration.
- 2.6 Lateral Resistance
- 2.6.1 The lateral resistance provided by nailed joints is frequently a critical factor in the strength and stability of a structure or its component parts. As mentioned previously, factors such as the wood, the nail, and conditions of use are generally not so pronounced under lateral loads as under withdrawal loads. However, they still are of considerable importance.

- 2.6.2 The spread in the lateral resistance between different species or members of low or high specific gravity is not so large as in withdrawal. While species are frequently grouped in tables to simplify presentation of loads, in general the loads for nails in side grain nailing vary about as the $1\frac{1}{4}$ power of specific gravity. On this basis an increase in specific gravity of 25 percent is accompanied by an increase of somewhat more than 30 percent in lateral loads.
- 2.6.3 While the large variation in properties of wood along and across the grain has considerable effect on the load-carrying capacity of most fastenings, the lateral load values for nails are approximately the same regardless of direction of bearing in the side grain of wood. When nails are driven into end grain, however, the values are somewhat less than when driven into side grain. The ratio varies with the amount of distortion but, for design purposes, the lateral resistance of nails in end grain is considered to be about two-thirds of that in side grain.
- 2.6.4 The factors that affect lateral resistance of nails, apart from the species and dimensions of wood members in the joint, are related primarily to the nail diameter, providing that the depth of penetration in the member receiving the point is adequate. Within the working range of design value, the lateral resistance is dependent on the resistance of the nail to bending and varies approximately as the $1\frac{1}{2}$ power of the diameter.
- 2.6.5 A somewhat higher maximum lateral load is obtained with nails that have a higher withdrawal resistance because, at the maximum load, some withdrawal occurs as well as bending of the nail and crushing of the wood. The maximum load, however, is usually obtained at a slip in the joint of 6mm ($\frac{1}{4}$ in) to more than 12 mm ($\frac{1}{2}$ in)

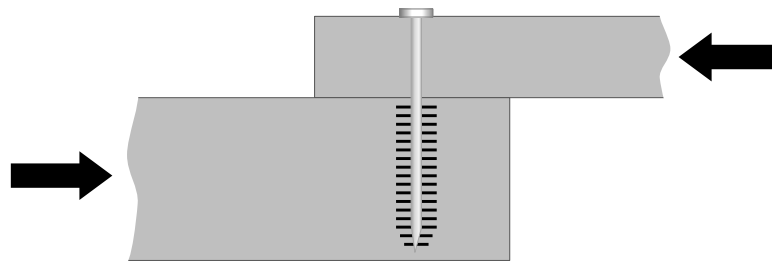

Figure Error! No text of specified style in document..14 Lateral joint under load

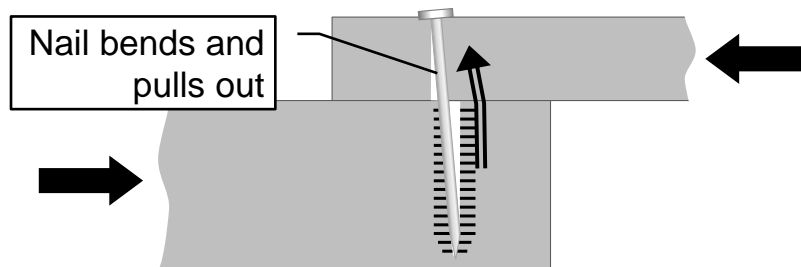

Figure Error! No text of specified style in document..15 Lateral slip

2.7 Depth of penetration

2.7.1 The lateral nail load is also related to the depth of penetration of the nail in the foundation member or member receiving the point. There are two general rules for the depth of penetration:

- .1 The depth of penetration generally recommended for plain-shank nails to develop full load varies from about 10 times the nail diameter for hardwoods to 14 times for the softer woods. For structural species it is usually taken at 11 times the diameter.

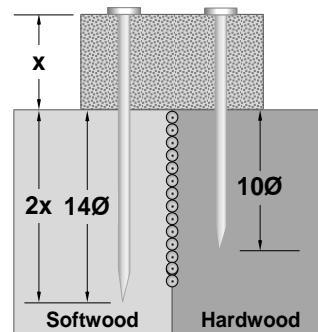

Figure **Error! No text of specified style in document..16** Depth of penetration

- .2 The depth of penetration can also be calculated so that the shank penetrates to a depth of twice the thickness of the affixed member.

2.7.2 For lesser depths of penetration, the maximum load tends to be reduced but not the load at smaller distortions. This results because the maximum lateral load is associated with nail withdrawal, whereas the load at smaller distortions is associated with the bending resistance of the nail. Since the maximum lateral load is associated with nail withdrawal, the depth of penetration required varies with the relative withdrawal resistance of the nails. For comparable maximum lateral loads, therefore, nails with a higher withdrawal resistance would require a somewhat smaller depth of penetration. This means that a wire nail with a spiral (S) or ringed (R) shank (see **Figure Error! No text of specified style in document..7**) can penetrate less into the fixed member than the standard Smooth (C) shank which may be of use when the thicknesses of the affixed and fixed members are similar.

2.8 Toenailing

2.8.1 While the nails in many joints serve a dual function of resisting withdrawal and lateral loads, the dual function is particularly evident in toenailed joints where the nails must resist separation between the two joined members in the plane of the members and at right angles to it.

2.8.2 Toenailing, when used to join wood framing members at right angles to each other, consists of slant driving a nail or group of nails through the end or edge of an attached member and into a main member. Tests show that the maximum strength of toenailed joints under lateral and uplift loads is obtained by:

- using the largest nail that will not cause excessive splitting;
- allowing an end distance (distance from end of the attached member to the point of initial nail entry) of approximately one-third the length of the nail;
- driving the nail at a slope of 30° with the attached member; and
- burying the full shank of the nail but avoiding excessive mutilation of the wood from hammer blows.

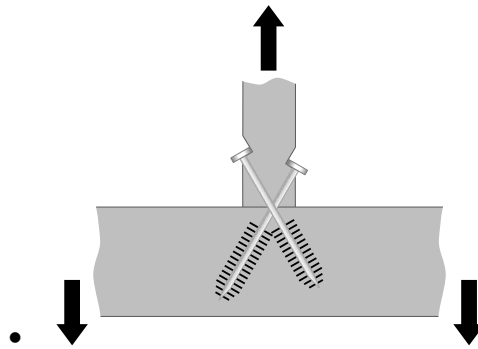

Figure **Error! No text of specified style in document..17** Toenailing

2.8.3 Toenailing requires greater skill in assembly but provides joints of greater strength and stability than does ordinary end nailing.

2.9 Spacing of Nails

2.9.1 The spacing of nails in multi-nail joints depends on the size and type of nail and tendency of the wood to split. The splitting tendency varies with so many factors that it is difficult to provide rules on spacing that are generally applicable. The splitting tendency first of all varies with species of wood. Usually the softer the wood the less likelihood of splitting, but splitting can also be affected by such factors as the relative hardness and structure of the wood as well as the ratio between the properties across and along the grain.

2.9.2 The moisture content of wood and variations in its moisture content also affect the tendency to split. While wood that is green tends to split less than wood that is dry, partially seasoned wood may actually split much more severely than dry wood. During drying, the outer surfaces of the wood dry first and tend to shrink, but the shrinkage is resisted by the inner core, which is still green and retains its original dimensions. Consequently, at certain stages in the drying process the outer surfaces of the member are in tension and split quite readily when pierced by a nail. The splitting may vary from day to day in the same wood member, depending on its moisture content and on the temperature and humidity in the surrounding atmosphere.

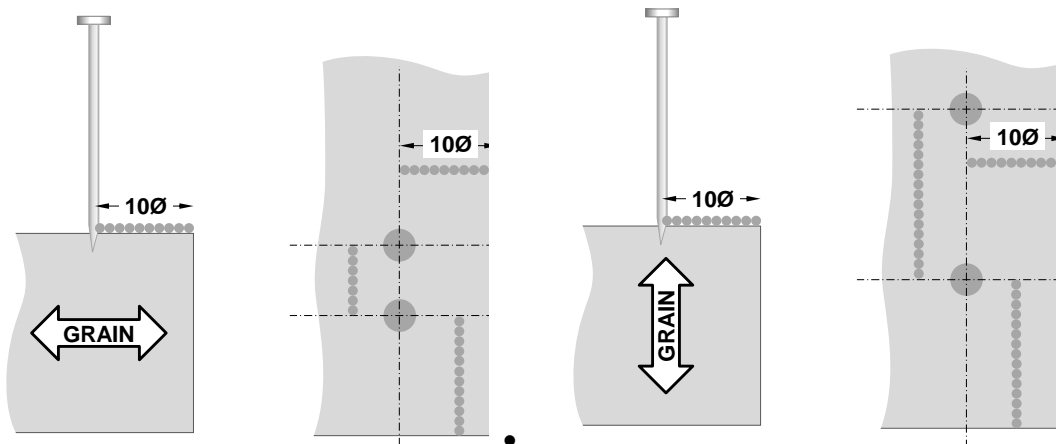

Figure **Error! No text of specified style in document..18** Perpendicular to grain

Figure **Error! No text of specified style in document..19** Parallel to grain

2.9.3 The rules developed for placement of nails in a multi-nail joint vary considerably with different investigators and agencies however the dimensions shown in Figure **Error! No text of specified style in document..18** and Figure **Error! No text of specified style in document..19** indicate the distances between nails and nails and edges.

2.9.4 Many additional factors may be considered when splitting of the wood is a problem. Some of these involve the wood and the nail and others involve the craftsmanship used

in driving the nail. They include:

- setting the nails as far from the end of the board as practical,
- using blunt-pointed nails rather than excessively sharp-pointed nails,
- boring pilot holes or
- “easing in” the nails.

2.9.5 Another important factor in reducing splitting is the use of hardened and high-strength nails so the same load may be attained with a smaller diameter of nail. Even the length-diameter ratio affects the amount of splitting considerably. Length of the more common sizes of the common wire nails is about 20 to 22 times the diameter and, in the larger sizes of nails, tends to produce considerable splitting.

2.9.6 Much less splitting may result with annular and helically threaded nails, as well as some boxnails, because they have smaller diameters in relation to their length than common nails. The diameter of some box nails is from 5 to 10 percent smaller for a given length of nail and for some annular and helically threaded nails is even smaller.

2.9.7 Cut nails with square tips shears the fibres, there is no wedging action across the grain; it is possible you can nail near the end of a board with no splitting.

3. Screwed joints

3.1 General

3.1.1 Screws have many advantages as fasteners for specific uses in wood construction. They have a relatively high resistance to withdrawal and greater permanence than many other types of fastenings. Screws are, therefore, a preferred fastening where the joint is subjected to rigorous treatment or where it may be necessary to take the members apart.

3.1.2 Wood screws are usually made of steel or brass, and may also be made in a nickel or blued finish. They are classified according to material, type, finish, shape of head, and diameter or gauge of wire from which they are made. The particular type required is dependent on its use.

3.1.3 The resistance of wood screws to withdrawal is closely related to the specific gravity of the wood, the diameter and length of the screw, the size of lead hole, and the type of screw thread and hole surface.

3.1.4 This resistance to withdrawal from the side grain of seasoned wood varies about as the square of the specific gravity of the wood. The relative design load in withdrawal resistance per inch of penetration for a 5 mm (No. 10) screw, for example, varies from about 333 N (75 lbf) in white pine to over 1.2kN (270 lbf) pounds in white oak. Withdrawal load of screws varies directly with the depth of penetration and the diameter of the screw. The limiting factor in the length is the failure of screw in tension.

3.1.5 The lateral resistance of screws is important in many uses. Under a lateral or side load, the strength of the joints increases about as the square of the screw diameter; when the diameter of the screw is doubled, the load is increased four times, The lateral resistance does not vary as much between species as the withdrawal resistance, but the effect of specific gravity on load is still large. The relative lateral design load for a 5mm (No. 10) screw, for example, is 403 N (90 lbf) in white pine and about 780 N (175 lbf) in white oak. The maximum load, of course, is considerably higher.

3.1.6 The load the screws will carry is affected to a considerable extent by the size of lead hole. Prebored lead holes are commonly required in order to reduce their tendency to split the wood and to facilitate insertion unless the wood is soft or special threaded screws are used. The best results are usually obtained with a lead hole for the threaded portion of a wood screw, or full length of a sheet metal screw, that has a diameter of 70 percent of the root diameter of the threads for softwoods and 90 percent for hardwoods.

3.2 Types of screw

3.2.1 Woods screws come in two basic formats, threaded to the head and with a plain unthreaded shank.



• Figure **Error! No text of specified style in document.**..20 Full thread



• Figure **Error! No text of specified style in document.**..21 Plain shank

3.2.2 Generally the head will be countersunk as shown on the figures above so that the screw head does not protrude above the surface of the timber. the screw heads are shown in sub-section 3.2.4.

3.2.3 The alternative to the standard wood screws is the coach or lag screw which generally will provide far higher withdrawal resistance. It also has a hexagonal head that can be driven with a spanner or socket and will normally require a flat or penny washer.



• Figure **Error! No text of specified style in document.**..22 Coach / lag screw

3.2.4 Screw heads

3.2.4.1 There are a large variety of drive heads available, but this annex will only concentrate on those that are suitable for framing.





• Drive	• Remarks	•
• Slot drive	• The slot screw drive has a single slot in the fastener head and is driven by a flat-bladed screwdriver. It was the first type of screw drive to be developed, and for centuries it was the simplest and cheapest to make. The slotted screw is common in simple woodworking applications, but is not often seen in applications where a power tool would be used because a power driver tends to slip out of the head and potentially damage the surrounding material	• 
• Phillips	• Created by Henry F. Phillips, the Phillips screw drive was purposely designed to cam out when the screw stalled[citation needed], to prevent the fastener damaging the work or the head, instead damaging the driver. This was caused by the relative difficulty in building torque limiting into the early drivers	• 
• Pozidriv	• The Pozidriv screw drive is an improved version of the Phillips screw drive. The name is thought to be a portmanteau of positive drive. Its advantage over Phillips drives is its decreased likelihood to cam out, which allows greater torque to be applied. • Phillips drivers have an intentional angle on the flanks and rounded corners so they will cam out of the slot before a power tool will twist off the screw head.	• 
• Phillips Square (Quadrex)	• The Phillips/square screw drive, also known as the Quadrex screw drive, is a combination of the Phillips and Robertson screw drives. While a standard Phillips or Robertson tool can be used, there is also a dedicated tool for it that increases the surface area between the tool and the fastener so it can handle more torque.	• 

Figure Error! No text of specified style in document..23 Screw head drives

3.2.4.2 The slot drive is the most common wood screw drive used manually although the Phillips and Pozidriv provide greater torque. The Pozidriv and the Quadrex drive are used when powered drivers are used and are recommended.

3.3 Bolted joints / anchor points

3.3.1 Machine screws may be used instead of nails or wood screws and access to both side of the joint is required. It is unlikely that this method will be used, however bolted anchor points may be used.

3.3.2 Anchor points fitted in a freight container are limited in number and strength. Additional anchor points can be provided by the use of forged / swaged eye bolts attached to the load distribution beams / pallets.

3.3.3 Eye bolts can be fitted either vertically or horizontally. Vertical anchor points rely on the strength of the timber through which the eye bolt passes, and the size of the washer backing the hexagonal nut. Horizontal points rely on the shear strength of the bolt plus the density of the timber. High lashing forces may crush the timber fibre. Such distortion may result in a reduction in lashing forces permitting greater movement of the coil.

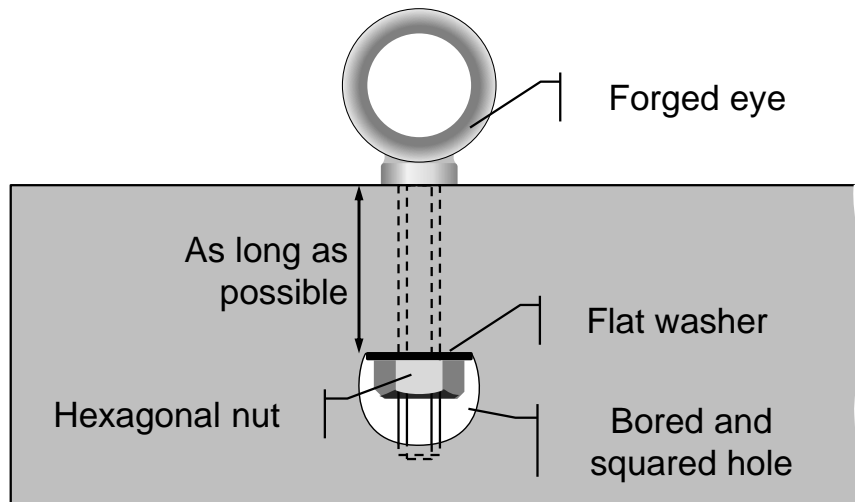

• Figure **Error! No text of specified style in document.**24 Vertical anchor point

3.3.4 The vertical anchor points can be tightened at the start and the inevitable crushing of the fibres can be compensated for before and after the lashing is attached.
