

Proposal for a new supplement to the 05, 06 and 07 Series of Amendments to UN Regulation No. 83

This document aims to:

- Equipment conforming to UN Regulation No. 154 may be used for UNR83 / 101 test.

	Equipment Requirement		
	common	UN Regulation No. 154 unique	UNR83 unique
UN Regulation No. 154 Tests	✓	✓	-
UNR83 Tests(current)	✓	-	✓
UNR83 Tests(OICA Proposal)	✓	✓	✓

UNR83 unique can be evolved and replaced with UN Regulation No. 154 unique

The modifications to the current text of the Regulation are marked in bold for new or strikethrough for deleted characters.

I. Proposal for Regulation No. 83

First paragraph of Appendix 1 to 6 of Annex 4a (Type I test); amend to read:

Annex 4a - Appendix 1 - Chassis dynamometer system

"1. Specification

1.1. General requirements

For test and measurement equipment that is compliant with the technical requirements of UN Regulation No. 154 original series or later version, the requirements on the technical equipment described in UN Regulation No. 154 may be followed, in all other cases the following requirements shall apply:

1.1.1. The dynamometer shall be capable of simulating road load within one of the following classifications: ..."

Annex 4a - Appendix 2 - Exhaust dilution system

"1.2. General requirements

For test and measurement equipment that is compliant with the technical requirements of UN Regulation No. 154 original series or later version, the requirements on the technical equipment described in UN Regulation No. 154 may be followed, in all other cases the following requirements shall apply:"

Annex 4a - Appendix 3 - Gaseous emissions measurement equipment

"1. Specification

For test and measurement equipment that is compliant with the technical requirements of UN Regulation No. 154 original series or later version, the requirements on the technical equipment described in UN Regulation No. 154 may be followed, in all other cases the following requirements shall apply:"

Annex 4a - Appendix 4 - Particulate mass emissions measurement equipment

"1. Specification

For test and measurement equipment that is compliant with the technical requirements of UN Regulation No. 154 original series or later version, the requirements on the technical equipment described in UN Regulation No. 154 may be followed, in all other cases the following requirements shall apply:"

Annex 4a - Appendix 5 - Particulate number emissions measurement equipment

- "1. Specification
For test and measurement equipment that is compliant with the technical requirements of UN Regulation No. 154 original series or later version, the requirements on the technical equipment described in UN Regulation No. 154 may be followed, in all other cases the following requirements shall apply:"

Annex 4a - Appendix 6 - Verification of simulated inertia

- "1. Object
The method described in this appendix makes it possible to check that the simulated total inertia of the dynamometer is carried out satisfactorily in the running phase of the operating cycle. The manufacturer of the dynamometer shall specify a method for verifying the specifications according to paragraph 3. of this appendix.
In case of the equipment that meets UN Regulation No. 154 requirements, this application may not be required."

Paragraph 4 of Annex 7 (Type4 test); amend to read:

- "4. Test equipment for evaporative test
For test and measurement equipment that is compliant with the technical requirements of UN Regulation No. 154 original series or later version, the requirements on the technical equipment described in UN Regulation No. 154 may be followed, in all other cases the following requirements shall apply:
- 4.1. Chassis dynamometer
The chassis dynamometer shall meet the requirements of Appendix 1 to Annex 4a to this Regulation."

Annex 7 - Appendix 1 - Calibration of equipment for evaporative emission testing

- "1. Calibration frequency and methods
For test and measurement equipment that is compliant with the technical requirements of UN Regulation No. 154 original series or later version, the requirements on the technical equipment described in UN Regulation No. 154 may be followed, in all other cases the following requirements shall apply:"

II. Justification

For OICA as well, we would like to make the following proposals in consideration of further operational efficiency.
In fact, the R154 equipment has been updated and regulated based on the R83 equipment, an example is shown below,
As reference, no modification on UNR101 is necessary since UNR101 refers UNR83 for equipment requirement.

Example 1: particulate sampling system

ECE R83/05 Annex 4 Appendix 5 shall be as indicated

- 2.4.4. The particulate sampling system shall consist of a sampling probe in the dilution tunnel and two series-mounted filters. Quick-acting valves shall be located both up and downstream of the two filters in the direction of flow.

The configuration of the sample probe shall be as indicated in Figure 5/2.

Figure 5/2
 Particulate sampling probe configuration

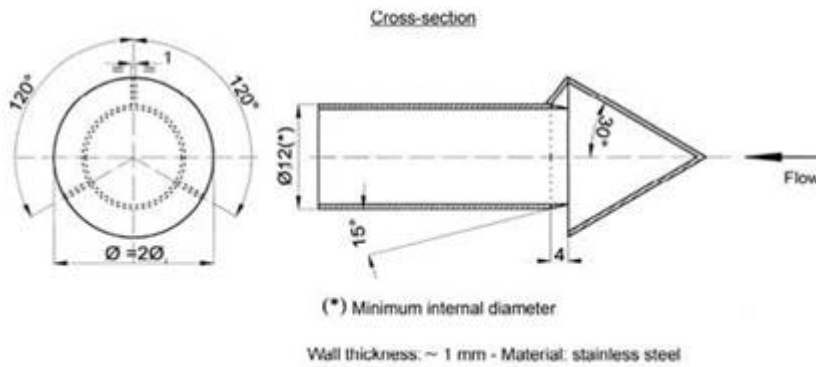

UN R 154 pre-classifier may be used

4.2. PM measurement equipment

4.2.1. Specification

4.2.1.1. System overview

4.2.1.1.1. The particulate sampling unit shall consist of a sampling probe (PSP), located in the dilution tunnel, a particle transfer tube (PTT), a filter holder(s) (FH), pump(s), flow rate regulators and measuring units. See Figures A5/11, A5/12 and A5/13.

4.2.1.1.2. A particle size pre-classifier (PCF), (e.g. cyclone or impactor) may be used. In such case, it is recommended that it be employed upstream of the filter holder.

Figure A5/11

Alternative particulate sampling probe configuration

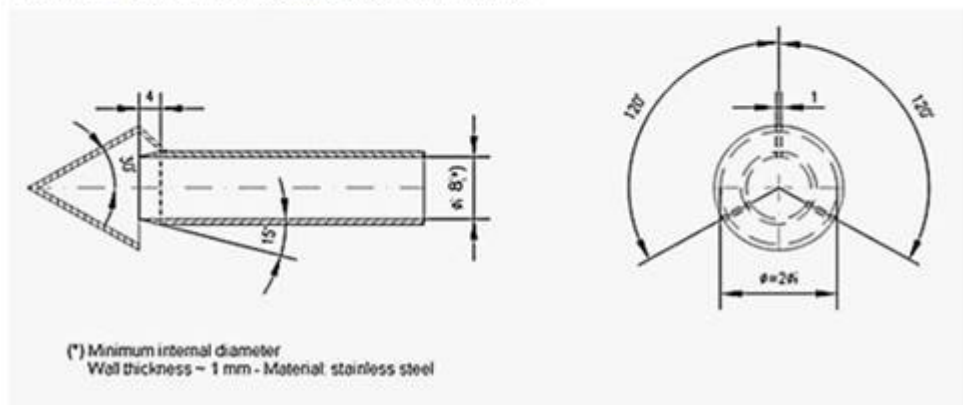

Example 2: length of pipe

ECE R83-05 Annex 4 Appendix 5 max. 3,6 m to dilution tunnel inlet

2.4.2. In order to reduce heat losses in the exhaust gases between the exhaust outlet and the dilution tunnel inlet, the pipe may not be more than 3.6 m long, or 6.1 m long if heat insulated. Its internal diameter may not exceed 105 mm.

UN R 154 max. 3,6 m ...or first point of dilution

3.3. Specific requirements

3.3.1. Connection to vehicle exhaust

3.3.1.1. The start of the connecting tube is the exit of the tailpipe. The end of the connecting tube is the sample point, or first point of dilution.

3.3.1.3. The connecting tube shall satisfy the following requirements:

- (a) Be less than 3.6 metres long, or less than 6.1 metres long if heat-insulated. Its internal diameter shall not exceed 105 mm; the insulating materials shall have a thickness of at least 25 mm and thermal conductivity shall not exceed $0.1 \text{ W/m}^2\text{K}^{-1}$ at 400 °C. Optionally, the tube may be heated to a temperature above the dew point. This may be assumed to be achieved if the tube is heated to 70 °C;