

# Manual of Tests and Criteria

*Seventh revised edition*

*Amendment 1*



**UNITED NATIONS**  
**New York and Geneva, 2021**

© 2021 United Nations  
All rights reserved worldwide

Requests to reproduce excerpts or to photocopy should be addressed to the Copyright Clearance Center at [copyright.com](http://copyright.com).

All other queries on rights and licenses, including subsidiary rights, should be addressed to:

United Nations Publications  
405 East 42nd Street, S-09FW001  
New York, NY 10017  
United States of America

Email: [permissions@un.org](mailto:permissions@un.org)  
website: <https://shop.un.org>

The designations employed and the presentation of the material in this publication do not imply the expression of any opinion whatsoever on the part of the Secretariat of the United Nations concerning the legal status of any country, territory, city or area, or of its authorities, or concerning the delimitation of its frontiers or boundaries.

United Nations publication issued by the United Nations Economic Commission for Europe.

ST/SG/AC.10/11/Rev.7/Amend.1

ISBN: 978-92-1-139186-2  
eISBN: 978-92-1-005207-8

ISSN: 1014-7160  
eISSN: 2412-4664

Sales number: E.21.VIII.2

## INTRODUCTION

The "Manual of Tests and Criteria" contains criteria, test methods and procedures to be used for the classification of dangerous goods according to the provisions of the *"United Nations Recommendations on the Transport of Dangerous Goods, Model Regulations"*, as well as of chemicals presenting physical hazards according to the *"Globally Harmonized System of Classification and Labelling of Chemicals (GHS)"*. It therefore also supplements national or international regulations which are derived from the Model Regulations or the GHS.

Originally developed by the Economic and Social Council's Committee of Experts on the Transport of Dangerous Goods, which adopted a first version in 1984, the Manual of Tests and Criteria has been regularly updated and amended. Currently, the updating is done under the auspices of the Committee of Experts on the Transport of Dangerous Goods and on the Globally Harmonized System of Classification and Labelling of Chemicals, which replaced the original committee in 2001.

At its tenth session (11 December 2020), the Committee adopted a set of amendments to the seventh revised edition of the Manual, which were circulated as document ST/SG/AC.10/48/Add.2. This publication lists those amendments. Chapter 28, which was more significantly revised, is reproduced here entirely, as amended.

The new amendments adopted in 2020 include:

- Transport of explosives, including alignment with revised Chapter 2.1 of the GHS;
- Classification of self-reactive substances and polymerising substances; and
- Assessment of the thermal stability of samples and temperature control assessment for transport of self-reactive substances and organic peroxides.



## TABLE OF CONTENTS

	<u>Page</u>
<b>AMENDMENTS TO PART I</b>	
Section 10.....	1
Section 13.....	2
Section 14.....	4
<b>AMENDMENTS TO PART II</b>	
Section 20.....	4
Section 28.....	9
<b>AMENDMENTS TO PART III</b>	
Section 33.....	33
Section 34.....	33
Section 37.....	33
Section 38.....	33
<b>AMENDMENTS TO PART IV</b>	
Section 41.....	34
<b>AMENDMENTS TO PART V</b>	
Section 51.....	34



## Section 10

10.1.2 Amend to read as follows:

“10.1.2 The GHS hazard class of explosives covers all sectors. Class 1 of the Model Regulations is a subset of this class and comprises explosives as configured for transport.

Goods of Class 1 must be assigned to one of the six divisions, depending on the type of hazard they present (see Chapter 2.1, paragraph 2.1.1.4 of the Model Regulations) and to one of the thirteen compatibility groups that identify the kinds of explosives that are deemed to be compatible. The division, and occasionally the compatibility group, is also used as a basis for classification in the GHS hazard class for explosives (see Chapter 2.1, section 2.1.2, of the GHS). In addition, the GHS hazard class also comprises explosives that are not assigned a division.

Explosives that are not assigned a division are forbidden for transport.”

The existing text in 10.1.2 starting with “The general scheme for...” is transferred to a new 10.1.3.

Renumber existing 10.1.3 and 10.1.4 as 10.1.4 and 10.1.5.

10.1.4 (renumbered) In the first sentence, replace “as presented” by “as configured”. In the last sentence, replace “transport classifications” by “classifications in the transport configuration”.

10.3.1.1 Amend to read as follows:

“10.3.1.1 The acceptance procedure is used to determine whether or not a substance or article as offered for classification is a candidate for the class of explosives. This is decided by determining whether a substance is either too insensitive for inclusion in this class or is accepted as an explosive but considered too sensitive to mechanical stimuli, heat or flame to assign a division; or whether the article or packaged article is accepted as an explosive but considered too sensitive to impact or heat to assign a division.”

Figure 10.1 In the box “CLASSIFY AS AN UNSTABLE EXPLOSIVE”, delete “UNSTABLE” and add a new line to read “No division assigned”.

Figure 10.2 In box 13, replace “unstable” by “too sensitive to assign a division”.

In box 16, replace “an unstable explosive” by “too sensitive to assign a division”.

Amend box 17 to read:

“CLASSIFY AS AN EXPLOSIVE  
No division assigned”

In box 19, replace “ACCEPT INTO THIS CLASS” by “CLASSIFY AS AN EXPLOSIVE”.

10.3.2.4 In the first sentence, replace “unstable” by “too sensitive to assign a division”.

10.3.2.5 In the first sentence, replace “an unstable explosive” by “too sensitive to assign a division”.

10.4.1.1 Amend the first two sentences to read as follows:

“Unless considered too sensitive to assign a division, explosives may be assigned one of six divisions, depending on the type of hazard they present (see paragraphs 2.1.1.4 of the Model Regulations and 2.1.2 of the GHS). Assigning a division is a prerequisite for the transport of explosives (see 10.1.2). The assignment procedure (figures 10.3 and 10.5) describes how to assign the division for explosive substances and articles. Explosives may also be declared from the outset to be in Division 1.1.”

In the next sentence, replace “assigned to” by “assigned”.

In the penultimate sentence, replace “2.1.1.2 (b) of the GHS” by “2.1.1.2.1 (b) of the GHS”.

Figure 10.4 In box 6, delete “unstable” and, at the end, add a full stop and “No division assigned.”.

In box 7, delete “other than as an unstable explosive” and replace the semicolon by a full stop.

Figure 10.6 (a) In the row for “Box 13”, replace “unstable” by “too sensitive to assign a division”.

Figure 10.6 (b) In box 13, replace “unstable” by “too sensitive to assign a division”.

In box 16, replace “an unstable explosive” by “too sensitive to assign a division”.

Amend box 17 to read:

“CLASSIFY AS AN EXPLOSIVE  
No division assigned”

In box 19, replace “ACCEPT INTO THIS CLASS” by “CLASSIFY AS AN EXPLOSIVE”.

Figure 10.7 (a) In the row for “Box 13”, replace “unstable” by “too sensitive to assign a division”.

Figure 10.7 (b) In box 13, replace “unstable” by “too sensitive to assign a division”.

In box 16, replace “an unstable explosive” by “too sensitive to assign a division”.

Amend box 17 to read:

“CLASSIFY AS AN EXPLOSIVE  
No division assigned”

In box 19, replace “ACCEPT INTO THIS CLASS” by “CLASSIFY AS AN EXPLOSIVE”.

## Section 13

13.1 Amend the text below the heading to read as follows and delete the note:

“This test series is used to answer the questions in boxes 12 and 13 of Figure 10.2 by determining the sensitiveness of the substance to mechanical stimuli (impact and friction), to heat and to flame. The question in box 12 is answered “no” if a “+” is obtained in test type 3 (c) and the substance is considered too sensitive to assign a division. The question in box 13 is answered “yes” if a “+” is obtained in any of the test types 3 (a), 3 (b) or 3 (d). If a “+” is obtained, the substance is considered too sensitive to assign a division in the form in which it was tested but may be encapsulated or otherwise desensitized or packaged to reduce its sensitiveness to external stimuli.”

13.4.1.1 In the first sentence, replace “an unstable explosive” by “too sensitive to assign a division”.

13.4.1.4.1 In the first sentence, replace “an unstable explosive” by “too sensitive to assign a division”.

13.4.1.4.2 In the first sentence, replace “an unstable explosive” by “too sensitive to assign a division”.

13.4.2.1 In the first sentence, replace “an unstable explosive” by “too sensitive to assign a division”.

13.4.2.4 In the paragraph after the indents, in the first sentence, replace “an unstable explosive” by “too sensitive to assign a division”.



- 13.4.3.1 In the first sentence, replace “an unstable explosive” by “too sensitive to assign a division”.
- 13.4.3.4.1 In the paragraph after the indents, in the first and last sentences, replace “an unstable explosive” by “too sensitive to assign a division”.
- 13.4.3.4.2 In the paragraph after the indents, in the third and penultimate sentences, replace “an unstable explosive” by “too sensitive to assign a division”.
- 13.4.4.1 Replace “an unstable explosive” by “too sensitive to assign a division”.
- 13.4.4.4 In the paragraph after the indents, in the first sentence, replace “an unstable explosive” by “too sensitive to assign a division”.
- 13.4.5.1 In the first sentence, replace “an unstable explosive” by “too sensitive to assign a division”.
- 13.4.5.4.2 In the first sentence, replace “an unstable explosive” by “too sensitive to assign a division”.
- 13.4.5.4.3 In the first sentence, replace “an unstable explosive” by “too sensitive to assign a division”.
- 13.4.6.1 Replace “an unstable explosive” by “too sensitive to assign a division”.
- 13.4.6.4.1 In the paragraph after the indents, in the first sentence, replace “an unstable explosive” by “too sensitive to assign a division”.
- 13.4.6.4.2 In the paragraph after the indents, in the first sentence, replace “an unstable explosive” by “too sensitive to assign a division”.
- 13.4.7.1 Replace “an unstable explosive” by “too sensitive to assign a division”.
- 13.4.7.5.1 In the first sentence, replace “an unstable explosive” by “too sensitive to assign a division”.
- 13.4.7.5.2 In the first sentence, replace “an unstable explosive” by “too sensitive to assign a division”.
- 13.5.1.1 Replace “an unstable explosive” by “too sensitive to assign a division”.
- 13.5.1.4 In the paragraph after the indents, in the first sentence, replace “an unstable explosive” by “too sensitive to assign a division”.
- 13.5.2.1 Replace “an unstable explosive” by “too sensitive to assign a division”.
- 13.5.2.4 In the paragraph after the indents, in the first and last sentences, replace “an unstable explosive” by “too sensitive to assign a division”.
- 13.5.3.1 Replace “an unstable explosive” by “too sensitive to assign a division”.
- 13.5.3.4 In the paragraph after the indents, in the first sentence, replace “an unstable explosive” by “too sensitive to assign a division”.
- 13.5.4.1 Replace “an unstable explosive” by “too sensitive to assign a division”.
- 13.5.4.5 In the first sentence, replace “an unstable explosive” by “too sensitive to assign a division”.
- 13.6.1.3.1 Replace “too thermally unstable for transport and shall be categorized as an unstable explosive” by “considered too sensitive to assign a division”.
- 13.6.1.4.2 Replace “, shall be categorised as an unstable explosive and is not permitted for transport” by “and therefore too sensitive to assign a division”.

- 13.6.2.4.2 Replace “, shall be categorised as an unstable explosive and is not permitted for transport” by “and therefore too sensitive to assign a division”.
- 13.7.1.3 In the paragraph after the indents, in the second sentence, replace “an unstable explosive” by “too sensitive to assign a division”.

## Section 14

- 14.1.1 In the first sentence, replace “too dangerous for transport” by “too sensitive to assign a division”.
- 14.4.1.1 In the first sentence, replace “too hazardous for transport” by “too sensitive to assign a division”.
- 14.4.1.4 In the first sentence, replace “too dangerous for transport” by “too sensitive to assign a division”.
- 14.5.1.4 In the first paragraph, replace “too dangerous to be transported” by “too sensitive to assign a division”.
- 14.5.2.4 In the first sentence, replace “too dangerous to transport” by “too sensitive to assign a division”.

## Section 20

- 20.3.3.3 In the first sentence, after “differential scanning calorimetry” add “(DSC)”.
- Modify the last sentence to read as follows: “If DSC is used, the onset temperature is defined as the temperature of the first noticeable exothermic effect (i.e. the heat production signal leaves the baseline).”

Insert a new section 20.3.4 to read as follows:

### **“20.3.4        *Thermal stability of samples and temperature control assessment for transport***

20.3.4.1        The provisions in this section are only applicable to samples in compliance with 2.4.2.3.2.4 (b) or 2.5.3.2.5.1 of the Model Regulations in cases where the SADT is not known.

20.3.4.2        If the decomposition onset in a DSC measured in accordance with 20.3.3.3 is found at 160 °C or above, the estimated SADT of the sample may be assumed to be greater than 55 °C. According to 2.4.2.3.4 of the Model Regulations, temperature control is not required in such cases. Isolated small exotherms less than 20 J/g preceding the main decomposition may be neglected.

20.3.4.3        For purposes of determining the need for temperature control, a thermal stress test based on DSC measurements may be applied as follows: A DSC is measured as outlined in 20.3.3.3 for the sample as offered for transport. A second sample is taken, and thermal stress is applied by tempering the sample in the closed DSC crucible at a defined constant temperature over a certain period of time. In standard cases, a 24-hour stress time is deemed sufficient. The stressed sample is then cooled to room temperature before being subjected to a DSC measurement at the same heating rate as before. If the decomposition behavior remains unchanged by comparison of the two DSCs in terms of decomposition onset, shape of curve, and energy within a measurement uncertainty of 10 %, the sample is considered stable at the applied stress temperature. For flat peaks with a maximum heat production of 0.2 W/g a deviation of 25 % is tolerable in temperature ranges below 250 °C and 40 % above this limit. If the stress test is passed according to these criteria at 60 °C, then no temperature control is required.

20.3.4.4        If the sample fails the stress test at 60 °C, then the same procedure should be applied at decreasing temperatures in steps of 10 K until the decomposition behavior remains unchanged. That

temperature should be deemed the estimated SADT of the sample, and the control and emergency temperatures may then be derived in accordance with section 28.2.3 and table 28.2.

20.3.4.5 Examples for passing the thermal stress test are shown in figure 20.2. Figure 20.3 contains examples of samples failing the stress test. A flow chart for the procedure is given in figure 20.4.

**Figure 20.2: Examples of samples passing the thermal stress test**

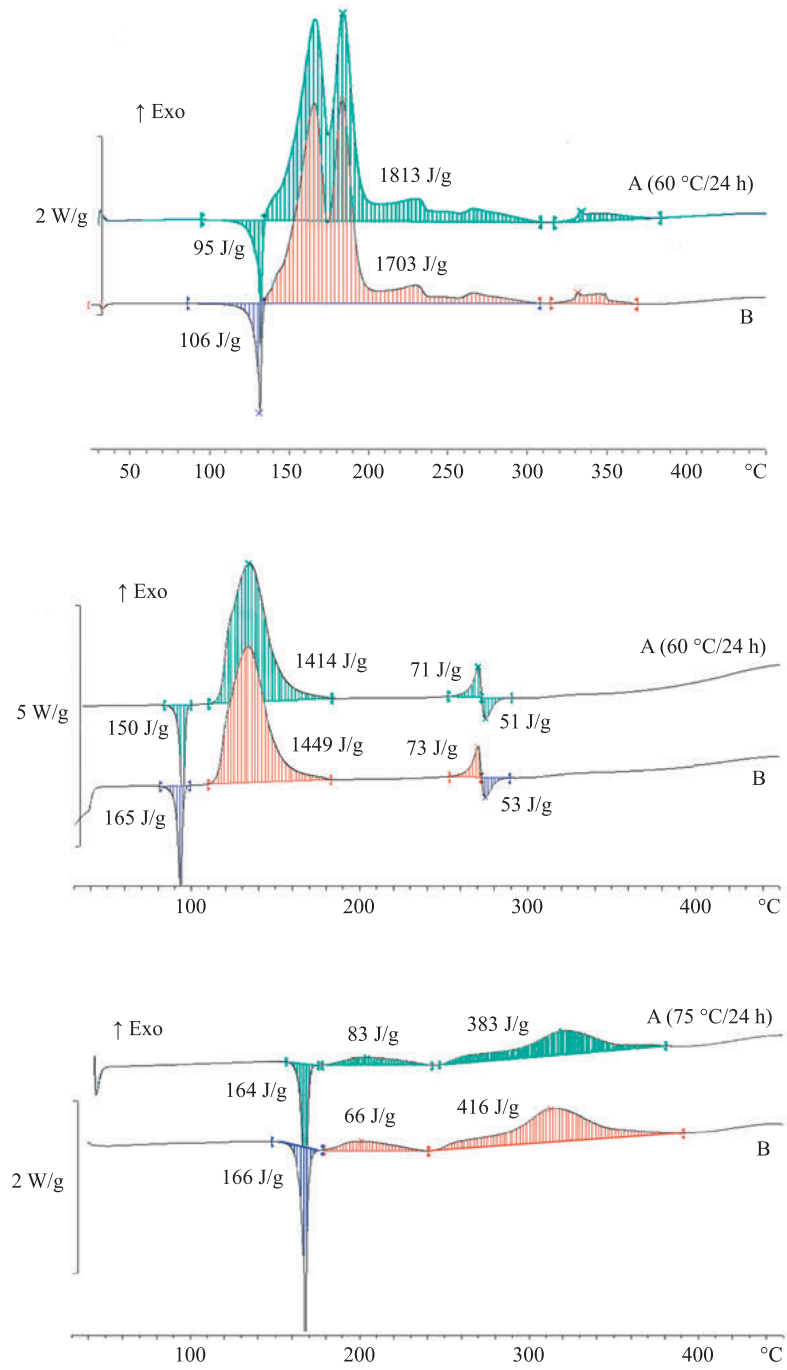

(A) Sample after thermal stress

(B) Original sample

Figure 20.2: Examples of samples passing the thermal stress test (continued)

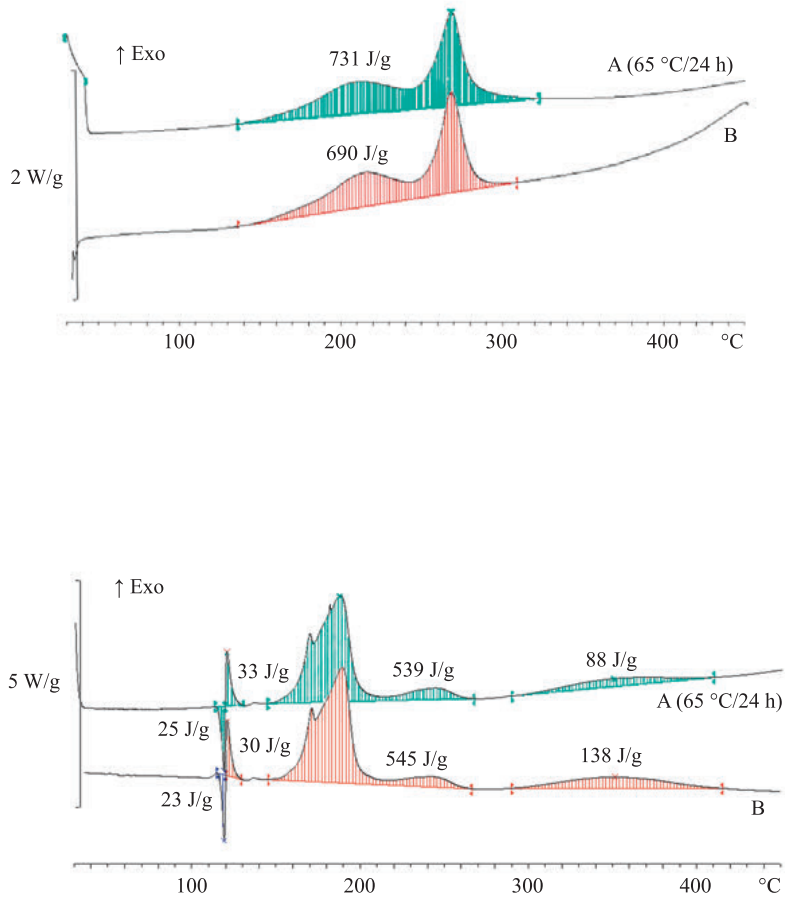

---

(A) Sample after thermal stress

(B) Original sample

---

**Figure 20.3: Examples of samples failing the thermal stress test**

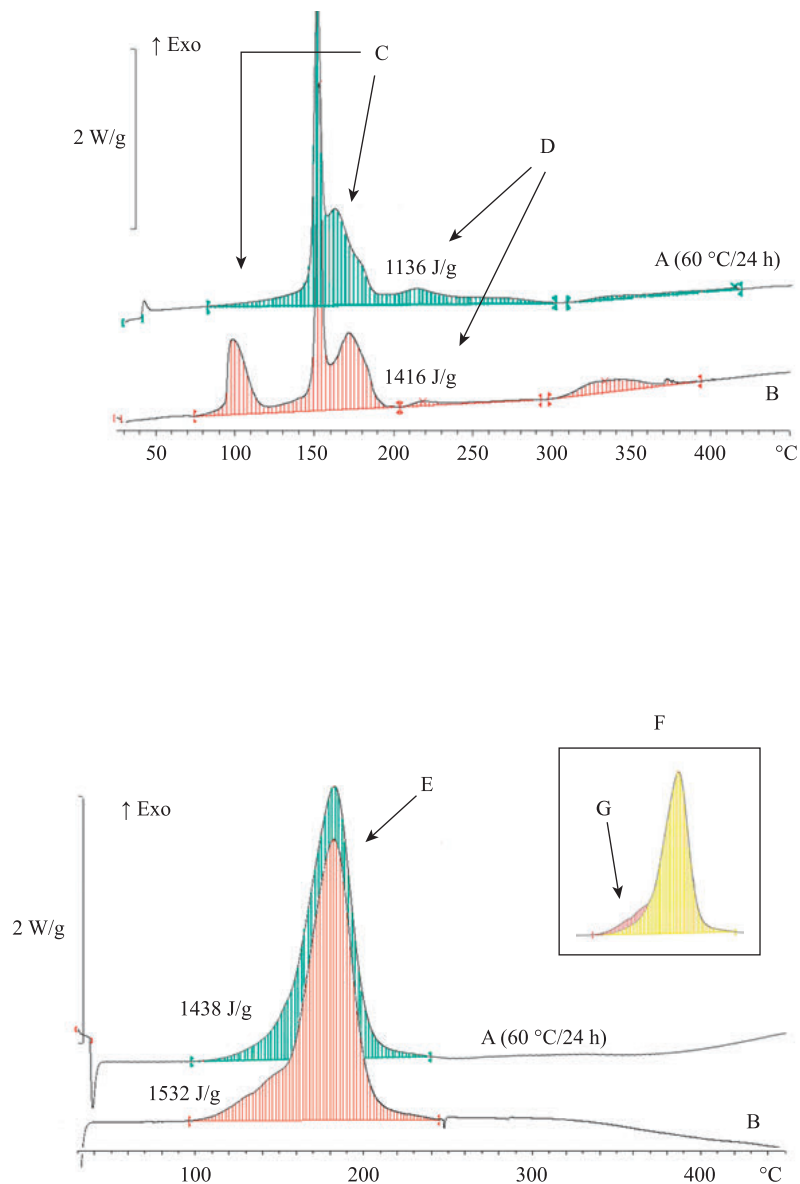

- 
- |   |   |
|---|---|
| (A) Sample after thermal stress                                   | (B) Original sample                                 |
| (C) Fail due to different peak shape                              | (D) Fail due to degradation (loss of energy > 10 %) |
| (E) Fail due to different peak shape in spite of tolerable energy | (F) Overlay of graphs                               |
| (G) Shoulder of peak missing after thermal stress                 |   |
-

**Figure 20.4: Flow chart scheme for the assessment of thermal stability of samples according to 20.3.4**

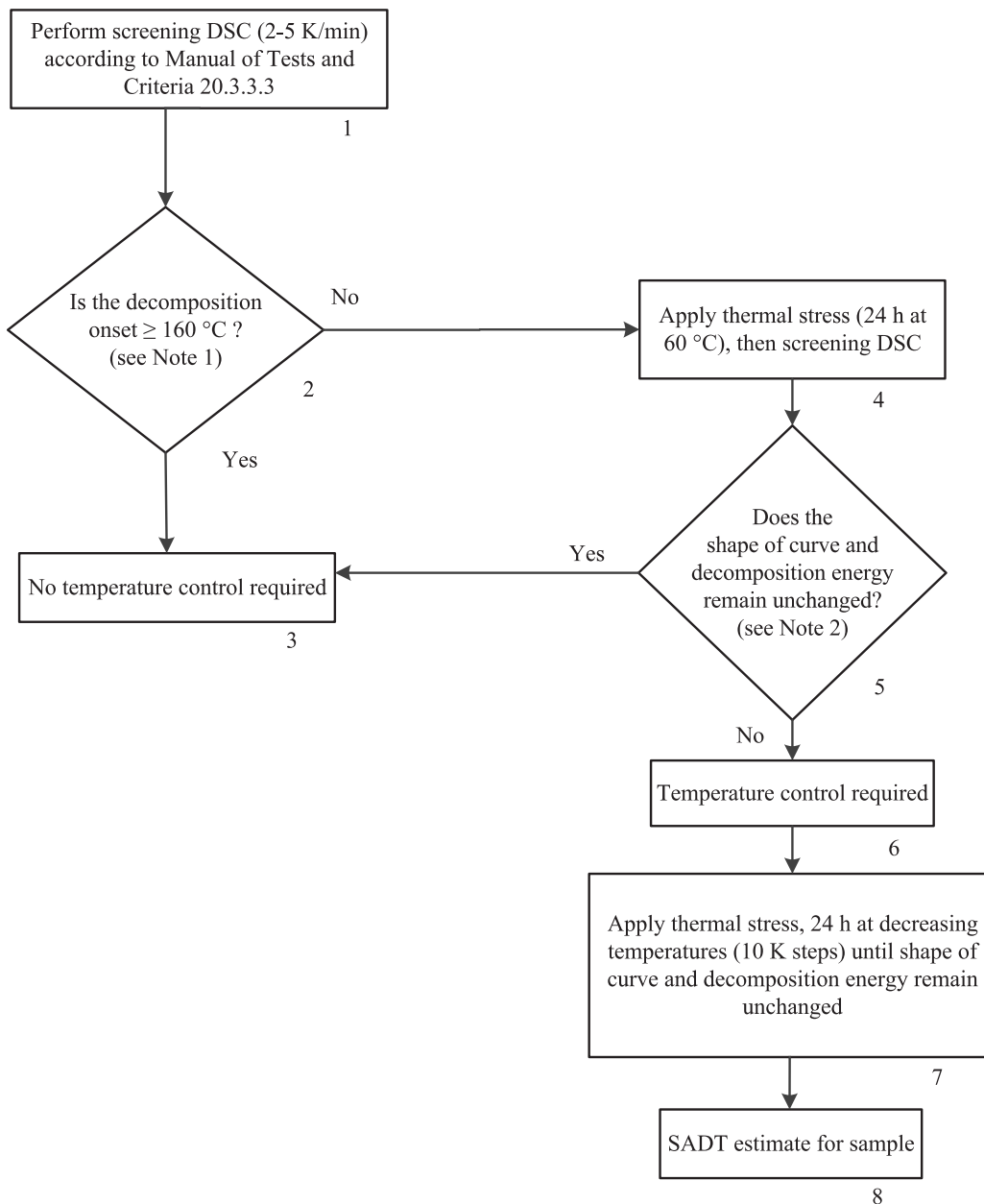

**NOTE 1:** *Isolated small exotherm (< 20 J/g) preceding the main decomposition may be neglected;*

**NOTE 2:** *General tolerance for energy comparison due to measurement uncertainty: 10 %. For flat peaks with a maximum heat production of 0.2 W/g a deviation of 25 % is tolerable in temperature ranges below 250 °C and 40 % above this limit.”*

Renumber figures 20.2 and 20.3 as 20.5 and 20.6 respectively and update cross references in paragraph 20.5.1.

**Section 28**

Amend to read as follows:

“

## SECTION 28

### TEST SERIES H

#### 28.1 Introduction

28.1.1 This test series contains test methods for the determination of the self-accelerating decomposition temperature (SADT) and the self-accelerating polymerization temperature (SAPT). The SADT is defined as the lowest temperature at which self-accelerating decomposition may occur with a substance in the packaging. The SAPT is defined as the lowest temperature at which self-accelerating polymerization may occur with a substance in the packaging. The SADT and SAPT are measures of the combined effect of the ambient temperature, reaction kinetics, package size and the heat transfer properties of the substance and its packaging. To assist in interpreting the results, the following models can be used<sup>1</sup>:

- (a) Semenov model, in which the main resistance to heat flow is at the boundary (i.e. packaging). This model is generally applicable to homogeneous liquids but can also be applied to solids in packagings (excluding IBCs);
- (b) Frank-Kamenetskii model, in which the main resistance to heat flow is within the substance. This model is generally applicable to solids in larger packagings, IBCs or tanks;
- (c) Thomas model, in which the resistance to heat flow is from both the boundary and the substance;
- (d) Non-stationary models, e.g. finite element methods (FEM), or computational fluid dynamics (CFD) all combined with thermal kinetic methods.

28.1.2 The text should be used in conjunction with the temperature control requirements given in subsection 2.5.3.4 of the Model Regulations.

28.1.3 Both the SADT and the SAPT may be influenced by factors such as aging of the sample, presence of stabilizers or impurities in the sample (including packaging materials in contact with the substance). These possible influencing factors should be considered when evaluating the results of an SADT or SAPT determination.

#### 28.2 Test methods

28.2.1 Test series H comprises tests and criteria concerning the thermal stability of substances or concerning the determination of whether a substance meets the definition of a self-reactive substance or a polymerizing substance.

28.2.2 Each test involves either storage at a fixed external temperature and observation of any reaction initiated or storage under near adiabatic conditions and measurement of the rate of heat generation versus temperature. The test methods included in test series H are given in Table 28.1. Each of the methods listed is applicable to solids, liquids, pastes and dispersions.

---

<sup>1</sup> References: N.N. Semenov, *Z. Physik*, 48, 1928, 571; D.A. Frank-Kamenetskii, *Zhur. Fiz. Khim.*, 13, 1939, 738; P.H. Thomas, *Trans. Faraday Soc.*, 54, 1958, 60.



**Table 28.1: Test methods for test series H**

Test code	Name of test	Section
H.1	United States SADT/SAPT test <sup>a</sup>	28.4.1
H.2	Adiabatic storage test (AST) <sup>b</sup>	28.4.2
H.3	Isothermal storage test (IST) <sup>b</sup>	28.4.3
H.4	Heat accumulation storage test <sup>c</sup>	28.4.4

<sup>a</sup> Recommended test for substances contained in packagings.

<sup>b</sup> Recommended test for substances contained in packagings, IBCs or tanks.

<sup>c</sup> Recommended test for substances contained in packagings, IBCs or small tanks.

The list of tests is not exhaustive; other tests may be used provided that they give the correct SADT or SAPT of the substance as packaged.

28.2.3 When temperature control is necessary (see Table 28.2) the control and emergency temperatures should be derived from the SADT or SAPT using Table 28.3.

**Table 28.2: Criteria for temperature control**

Type of substance	Criterion for temperature control
Self-reactive substance	SADT ≤ 55 °C
Organic peroxide Type B and C	SADT ≤ 50 °C
Organic peroxide Type D showing medium effect when heated under confinement <sup>a</sup>	SADT ≤ 50 °C
Organic peroxides Type D showing low or no effect when heated under confinement <sup>a</sup>	SADT ≤ 45 °C
Organic peroxides Type E and F	SADT ≤ 45 °C
Polymerizing substance in packaging or IBC	SAPT ≤ 50 °C
Polymerizing substance in portable tank	SAPT ≤ 45 °C

<sup>a</sup> As determined by test series E as prescribed in this Manual of Tests and Criteria, Part II.

**Table 28.3: Derivation of control and emergency temperatures**

Type of receptacle	SADT/SAPT <sup>a</sup>	Control temperature	Emergency temperature
Single packagings and IBCs	≤ 20 °C	20 °C below SADT/SAPT	10 °C below SADT/SAPT
	over 20 °C to 35 °C	15 °C below SADT/SAPT	10 °C below SADT/SAPT
	over 35 °C	10 °C below SADT/SAPT	5 °C below SADT/SAPT
Portable tanks	≤ 45 °C	10 °C below SADT/SAPT	5 °C below SADT/SAPT

<sup>a</sup> i.e. the SADT/SAPT of the substance as packaged.

28.2.4 If a substance is being tested to determine whether it is a self-reactive substance, a test of series H, or a suitable alternative test, should be performed to determine if its SADT would be less than or equal to 75 °C when contained in a 50 kg package.

28.2.5 If a substance is being tested to determine whether it is a polymerizing substance, a test of series H, or a suitable alternative method, should be performed to determine if its SAPT would be less than or equal to 75 °C in its packaging, IBC or portable tank.

28.2.6 The results obtained for larger packages are applicable to smaller packages of similar construction and material provided that the heat transfer per unit mass is no smaller than from the larger package.

### 28.3 Test conditions

28.3.1 For organic peroxides and self-reactive substances the preliminary procedure (see section 20.3) should be performed and the effect of heating under confinement (test series E) determined before performing SADT tests. ***Safety precautions should be taken which allow for the possibility of catastrophic failure of the test vessel and for the hazards arising from the ignition of secondary fuel-air mixtures and the evolution of toxic decomposition products. Substances liable to detonate should only be tested with special precautions.***

28.3.2 The test selected should be conducted in a manner which is representative, both in size and material, of the package. For metal packagings, IBCs or tanks, it may be necessary to include a representative amount of the metal in the sample tested i.e. representative of both the metal(s) and the area of contact.

28.3.3 ***Extra care should be taken when handling samples which have been tested since changes may have occurred rendering the substance more unstable and more sensitive. Tested samples should be destroyed as soon as possible after the test.***

28.3.4 Samples which have been tested at a particular temperature and are apparently unreacted may be used again, for screening purposes only, provided extra care is taken. Fresh samples should be used for the final determination of the SADT or SAPT.

28.3.5 If the complete package is not tested, the heat loss data used for the determination of the SADT or SAPT should be representative of the package, IBC or tank. For all type of packagings up to 50 kg for solids or 200 kg/225 litres for liquids and for IBCs up to 1250 litres for liquids, a standard heat loss per unit of mass is given in Table 28.4. For other packagings, IBC's or tanks or when there is a need for a heat loss value that deviates from the one as given in Table 28.4, the actual heat loss value per unit of mass has to be determined. In this case, the heat loss per unit of mass of the package, IBC or tank may be determined by calculation (taking account of the quantity of substance, dimensions of the package, heat transfer in the substance, heat transfer through the packaging and heat transfer through the outer wall of the packaging to the environment (see note)) or by measuring the half-time of cooling of the package filled with the substance or another substance having similar physical properties. The heat loss per unit mass,  $L$  (W/kg.K), can be calculated from the half-time of cooling,  $t_{1/2}$  (s), and the specific heat,  $C_p$  (J/kg.K), of the substance using the formula:

$$L = \ln 2 \times \left( \frac{C_p}{t_{1/2}} \right)$$

**NOTE:** For calculations, an external heat transfer coefficient (i.e. heat transfer from the outer wall of the packaging to the environment) of 5 W/m<sup>2</sup>.K can be used.

28.3.6 The half-time of cooling can be determined by measuring the period of time in which the temperature difference between the sample and its surroundings is decreased by a factor of 2. For example, for liquids, the packaging may be filled with silicone oil, apparent density  $0.96 \pm 0.02$  at 20 °C and heat capacity  $1.46 \pm 0.02$  J/g at 25 °C or dimethyl phthalate and this heated to about 80 °C. Water should not be used as erratic results may be obtained through evaporation/condensation. For solids, for example, the packaging may be filled with dense soda ash (apparent density greater than 1 g/cm<sup>3</sup>) and this is heated to about 80 °C. The temperature drop is measured at the centre of the package over the temperature range which includes the expected SADT or SAPT. For scaling, it may be necessary continuously to monitor the temperature of the substance and surroundings and then use linear regression to obtain the coefficients of the equation:

$$\ln \{T - T_a\} = c_0 + c \times t$$

where:  $T$  = substance temperature (°C);  
 $T_a$  = ambient temperature (°C);  
 $c_0$  =  $\ln\{\text{Initial substance temperature} - \text{initial ambient temperature}\}$ ; and  
 $c$  =  $L/C_p$ ;  
 $t$  = time (s).

28.3.7 Standard heat loss characteristics of packages, IBCs and tanks are given in Table 28.4. The actual value obtained will depend on the shape, wall thickness, surface coating etc. of the packaging.

**Table 28.4: Heat loss per unit mass from packages, IBCs and tanks**

Type of receptacle	Normal capacity	Heat loss per unit mass, L (mW/K·kg) <sup>a</sup>
<b>For liquids:</b>		
Packagings	up to 200 kg/225 l	40 <sup>b</sup>
Packagings	larger than 200 kg/225 l	no standard value <sup>c</sup>
IBCs	up to 1250 l	30
IBCs	larger than 1250 l	no standard value <sup>c</sup>
Tanks	-	no standard value <sup>c</sup>
<b>For solids:</b>		
Packagings	up to 50 kg	30 <sup>b</sup>
Packagings	larger than 50 kg	no standard value <sup>c</sup>
IBCs	-	no standard value <sup>c</sup>
Tanks	-	no standard value <sup>c</sup>

<sup>a</sup> For test series H.4 the heat loss of the Dewar vessel to be used should be as close as possible to the value listed in the table.

<sup>b</sup> When determining the SADT for exemption or classification purposes, where the definition of the SADT is connected to a 50 kg package, a value of 60 mW/K·kg for liquids and 30 mW/K·kg for solids should be used. Such is the case when the SADT is used either to exclude a new substance from Division 4.1 as a self-reactive substance (see 20.2.1 (e)), or to classify it under Type G as a self-reactive substance (see 20.4.2 (g)), or organic peroxide (see 20.4.3 (g)).

<sup>c</sup> Value should be determined for the actual configuration.

## 28.4 Series H test prescriptions

### 28.4.1 *Test H.1: United States SADT/SAPT test*

#### 28.4.1.1 *Introduction*

This method determines the minimum constant temperature air environment at which self-accelerating decomposition or polymerization occurs for a substance in a specific package. Packages of up to 225 litres may be tested by this method. An indication of the explosion hazard from the decomposition can also be obtained.

#### 28.4.1.2 *Apparatus and materials*

28.4.1.2.1 The test substance and packaging should be representative of that intended for commercial use. The packaging forms an essential part of the test.

28.4.1.2.2 The apparatus consists of a test chamber in which the air surrounding the package under test can be maintained at a constant temperature for a period of at least ten days.

28.4.1.2.3 The test chamber should be constructed such that:

- (a) It is well insulated;
- (b) Thermostatically controlled air circulation is provided so as to maintain a uniform air temperature within  $\pm 2$  °C of the desired temperature; and
- (c) The minimum separation distance for all sides from the package to the wall is 100 mm.

Any type of oven may be used provided that it is capable of meeting the temperature control requirements and will not ignite any decomposition products. Examples of suitable small-package and large-package ovens are described below.

##### 28.4.1.2.3.1 Example 1

A small-package oven may be constructed from an open head 220 litre steel drum. This will readily accommodate packages of up to 25 litres capacity. Construction details are shown in Figure 28.4.1.1. Larger packages may be tested as long as a 100 mm clearance between the package and the oven wall is maintained.

##### 28.4.1.2.3.2 Example 2

An expendable large-package oven may be made from 50 mm × 100 mm lumber formed into a cubic frame 1.2 m on each side, which is lined inside and out with 6 mm thick waterproof plywood and insulated all around with 100 mm fibreglass insulation. Construction details are shown in Figure 28.4.1.2. The frame should be hinged on one side to permit loading and unloading of test drums. The floor should be provided with 50 mm × 100 mm lumber on edge, spaced 200 mm on centres to keep the test container off the floor and allow free air circulation around the package. Cleats should run normal to the door to permit a fork-lift to move the drums. A circulating fan should be located on the side opposite the door. The air flow should be from the upper corner of oven to the fan discharge at the diagonally opposite lower corner. An electric heater of 2.5 kW is suitable for heating the air. Thermocouples should be placed in the air intake and outflow ducts as well as the top, middle and bottom of the oven. For substances with an SADT or SAPT below ambient temperature, the test should be performed in a cooling chamber or solid carbon dioxide should be used for cooling the oven.

##### 28.4.1.2.3.3 Example 3

For tests at temperatures up to 75 °C, a double walled metal chamber (minimum separation distance from the package to the wall is 100 mm) may be used with fluid from a temperature-controlled

circulating bath passed between the walls at the desired temperature. The test chamber is loosely closed by an insulated lid (e.g. made from 10 mm thick polyvinyl chloride). The temperature control should allow the desired temperature for a liquid inert sample to be maintained with a deviation of not more than  $\pm 2$  K for up to 10 days.

28.4.1.2.4 The package should be equipped with a thermowell which positions the thermocouple or Resistance Temperature Detector (RTD) at the package mid-point. The thermowell may be constructed of glass, stainless steel or other suitable material but should be introduced in a manner which does not reduce package strength or venting capability.

28.4.1.2.5 Continuous temperature-measuring and recording equipment, which is protected from fire and explosion hazards, is required.

28.4.1.2.6 ***The tests should be performed in an area which provides adequate protection from fire and explosion hazards, and from toxic fumes. A safety distance, e.g. 90 m, from public roads and occupied buildings is recommended. If there may be toxic fumes, longer safety distances may be required.***

28.4.1.3 *Procedure*

28.4.1.3.1 The package is weighed. A thermocouple or RTD is inserted in the package to be tested such that the temperature in the centre of the sample can be monitored. If the required oven temperature is below ambient, the oven is switched on and the inside of the oven cooled to the desired temperature before placing the package in the oven. If the required oven temperature is at or above ambient temperature, the package is inserted in the oven at ambient temperature and the oven then switched on. There should be a minimum clearance of 100 mm between the package and the sides of the oven.

28.4.1.3.2 The sample is heated and the temperature of the sample and test chamber continuously monitored. The time is noted at which the sample temperature reaches a temperature 2 °C below the test chamber temperature. The test is then continued for a further seven days or until the sample temperature rises to 6 °C or more above the test chamber temperature if this occurs sooner.

28.4.1.3.3 When the test is completed, cool the sample and remove it from the test chamber. Note the variation of temperature with time. If the package remains intact, note the percentage mass loss and determine any changes in composition. Dispose of the sample as soon as possible.

28.4.1.3.4 If the temperature of the sample does not exceed the oven temperature by 6 °C or more then repeat the test with a new sample in an oven at a 5 °C higher temperature. The SADT or SAPT is defined as the lowest oven temperature at which the sample temperature exceeds the oven temperature by 6 °C or more. If the substance is being tested to determine if temperature control is necessary, perform sufficient tests to determine the SADT or SAPT to the nearest 5 °C or to determine if the SADT or SAPT is greater than the applicable temperature specified in Table 28.2.. If the substance is being tested to determine if it meets the SADT criterion for a self-reactive substance, perform sufficient tests to determine if the SADT for a 50 kg package is 75 °C or less. If the substance is being tested to determine if it meets the SAPT criterion for a polymerizing substance, perform sufficient tests to determine if the SAPT in the packaging as used is 75 °C or less.

28.4.1.4 *Test criteria and method of assessing results*

28.4.1.4.1 The SADT or SAPT is reported as the lowest temperature at which the sample exceeds the oven temperature by 6 °C or more. If the sample temperature does not exceed the oven temperature by 6 °C or more in any test, the SADT or SAPT is recorded as being greater than the highest oven temperature used.

28.4.1.5 *Examples of results*

<b>Substance</b>	<b>Sample mass (kg)</b>	<b>Packaging</b>	<b>SADT/SAPT (°C)</b>
tert-Amyl peroxybenzoate	18.2	6HG2, 22.8 litres	65
tert-Butyl peroxyacetate (60 %)	7.2	6HG2, 22.8 litres	75
Dibenzoyl peroxide	0.45	1G	70
Di-(4-tert-butylcyclohexyl) peroxydicarbonate	43	1G	40
2,5-Diethoxy-4-morpholinobenzene-diazonium zinc chloride (66 %)	30	1G, 50 litres	50
2-(N-ethoxycarbonyl-N-phenylamino)-3-methoxy-4-(N-methyl-N-cyclohexylamino)benzenediazonium zinc chloride (62 %)	10	6HG1, 25 litres	50
Didecanoylperoxide, technically pure	20	1G	40
2,2'-Azodi-(isobutyronitrile)	50	1G	50

**Figure 28.4.1.1: Small package oven (Example 1)**

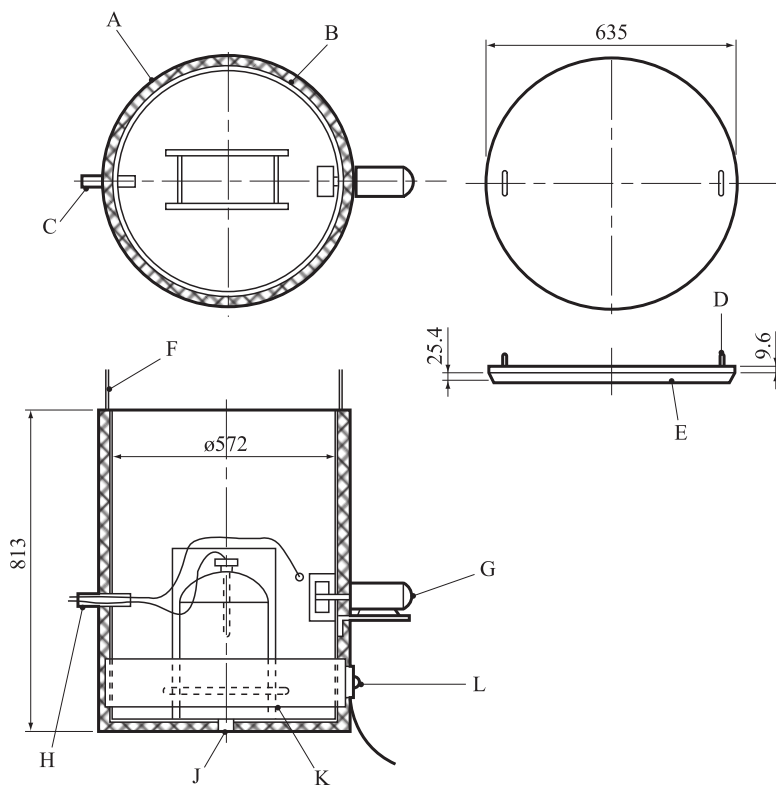

- 
- |                               |                                    |
|-------------------------------|------------------------------------|
| (A) Insulation 25 mm thick    | (B) 220 litres open top drum       |
| (C) 19 mm pipe                | (D) 9.6 mm eye bolt in steel cover |
| (E) Insulation on steel cover | (F) 3 mm control cable             |
| (G) Fan                       | (H) Thermocouples and controls     |
| (J) Drain                     | (K) 25 mm angle stand              |
| (L) 2 kW drum heater          |                                    |
-

Figure 28.4.1.2: Large package oven (top view and side view) (Example 2)

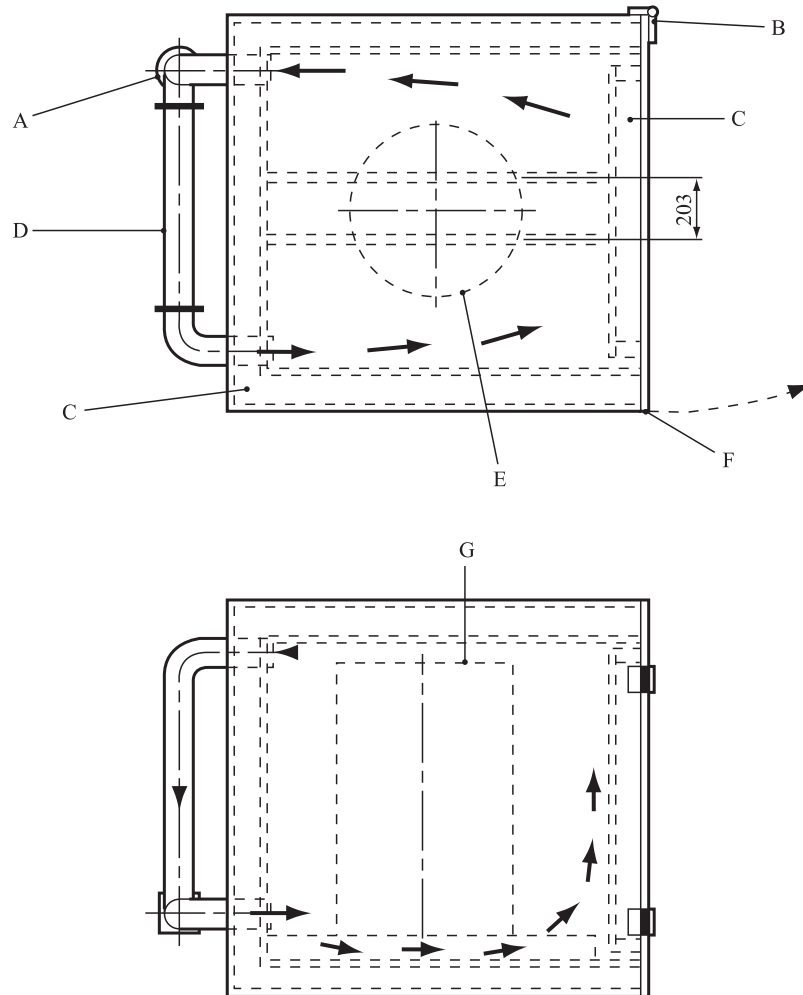

- 
- |                                 |                |
|---------------------------------|----------------|
| (A) Fan                         | (B) Hinges (2) |
| (C) Insulation                  | (D) Heater     |
| (E) Drum                        | (F) Latch      |
| (G) Drum (e.g. 0.58 m x 0.89 m) |                |
-



## 28.4.2 *Test H.2: Adiabatic storage test*

### 28.4.2.1 *Introduction*

28.4.2.1.1 This test method determines the rate of heat generation produced by a reacting substance as a function of temperature. The heat generation parameters obtained are used with the heat loss data of the package to determine the SADT or SAPT of a substance in its packaging. The method is appropriate for every type of packaging, including IBCs and tanks. There are two versions of the adiabatic storage test:

- (a) Open version: A Dewar vessel within an oven is used. This set-up uses a capillary to prevent pressure build-up and a cooling system to limit the temperature increase due to a thermal runaway reaction;
- (b) Closed version: A test vessel (e.g. Dewar or thin-walled vessel) is placed within an autoclave in an oven. Here the autoclave prevents the release of pressure to the surroundings during the test.

28.4.2.1.2 The smallest temperature rise that can be detected with this method depends on the properties of the sample, but generally corresponds to a heat generation rate of 15 mW/kg. The upper limit of the open version is determined by the capacity of the cooling system to safely cool the substance (up to 500 W/kg if water is used as coolant). The closed version can disregard this limit if performed in a high-pressure autoclave. The maximum allowable error in heat generation is 30 % at 15 mW/kg and 10 % from 100 mW/kg to 10 W/kg. The detection limit of the adiabatic test should be suitable for assessing the heat loss from the package under consideration (e.g. 100 to 500 mW/kg for  $L = 60 \text{ mW/K}\cdot\text{kg}$ ). If significant extrapolation of heat production rates derived from adiabatic test data is required, a validation with additional isothermal tests is recommended.

28.4.2.1.3 An explosion may occur in the open version of the test if the cooling system is activated at a stage where the rate of heat generation exceeds the cooling capacity of the apparatus. For the closed version an explosion could lead to a rupture of the autoclave or its fittings. ***The test site should therefore be carefully selected to reduce to a minimum the possible hazards from an explosion and of a possible subsequent gas explosion of the decomposition products (secondary explosion).***

### 28.4.2.2 *Apparatus and materials*

#### 28.4.2.2.1 Open version

The apparatus consists of a glass Dewar vessel (max. 3 litres) to contain the sample, an insulated oven with a differential control system to keep the temperature in the oven to within 0.1 °C of the sample temperature, and an inert lid for the Dewar vessel. In special cases, sample holders of other construction materials may have to be used. An inert heating coil and cooling tube pass through the lid into the sample. Pressure build-up in the Dewar vessel is prevented by a sufficiently long capillary tube made of an inert substance (e.g. 2 m long PTFE tube) through the insulated lid. A constant power heating unit is used for internal heating of the substance to a pre-set temperature or for calibration. Internal heating and cooling may be stopped or started automatically at pre-set temperatures. In addition to the cooling system, a secondary safety device is used to disconnect the power supply to the oven at a pre-set temperature. A schematic drawing of an open apparatus for the adiabatic storage test is given in Figure 28.4.2.1.

#### 28.4.2.2.2 Closed version

28.4.2.2.2.1 The apparatus consists of a suitable inert vessel (e.g. Dewar or thin-walled test cell) to contain the sample, a high-pressure autoclave and an insulated oven with a differential temperature control system. Thin-walled test cells require the use of a pressure control system to balance the internal and external cell pressure.

28.4.2.2.2.2 The phi-factor (heat capacity of the set-up and the sample divided by heat capacity of the sample) of the system should be known and be considered in evaluating the tests results. Therefore, a suitable combination of phi-factor, insulation, and amount of substance should be chosen. The heat losses from the

apparatus and detection limit of the system also have to be taken into consideration. An inert heating coil may be inserted into the sample. In addition to the high-pressure autoclave, a secondary safety device is used to disconnect the power supply to the oven at a pre-set temperature.

28.4.2.2.2.3 The closed version of the test is preferred for substances with a high vapour pressure at the test temperature to prevent mass loss due to evaporation or for substances that decompose with severe pressure rises (which in case of an open version of the test would throw off the insulated lid or eject the sample from the test cell). The weight of the sample should be determined after the measurement to detect mass loss during the test. Leakage from the system and the resulting evaporation cooling can result in a significant loss of sensitivity in the test and a large margin of error in the results. The suitability of a test run in the open version can be evaluated by determining the mass loss of the sample after the test.

28.4.2.2.3 The temperature of the substance is measured at its centre by means of thermocouples or platinum resistance sensors (RTD) placed in a steel or glass tube. The temperature of the surroundings is measured at the same height as the sample temperature, also with thermocouples or platinum resistance sensors. Continuous temperature measuring and recording equipment is required to monitor the temperature of the substance as well as (the air) in the oven. This equipment should be protected from fire and explosion. For substances with an SADT or SAPT below ambient temperature, the test should be performed with sufficient cooling.

### 28.4.2.3 Procedure

#### 28.4.2.3.1 Validation procedures

(a) The validation procedure A is as follows:

- (i) Fill the Dewar vessel with a suitable inorganic salt, preferably with similar physical properties to the test substance (e.g. sodium chloride or dense soda ash). Alternatively, an oil of known specific heat capacity at the temperature of interest (e.g. silicone oil, apparent density  $0.96 \pm 0.02$  at  $20\text{ }^{\circ}\text{C}$  and heat capacity  $1.46 \pm 0.02$  J/g at  $25\text{ }^{\circ}\text{C}$ ) may be used;
- (ii) Place the Dewar vessel in the vessel holder of the oven and heat the validation substance in  $20\text{ }^{\circ}\text{C}$  steps using the internal heating system at a known power rating (e.g.  $0.333\text{ W}$  or  $1.000\text{ W}$ ) and determine the heat losses at  $40\text{ }^{\circ}\text{C}$ ,  $60\text{ }^{\circ}\text{C}$ ,  $80\text{ }^{\circ}\text{C}$  and  $100\text{ }^{\circ}\text{C}$ ;
- (iii) Use the data to determine the heat capacity of the Dewar vessel and the test set-up using the method given in 28.4.2.4.

(b) The validation procedure B is as follows:

- (i) In order to perform validation procedure B the test set-up should be well characterized (e.g. by performing validation procedure A first);
- (ii) The test set-up must be validated using the method described in 28.4.2.4 with at least two standard substances or mixtures. Suitable choices for these standards are dicumylperoxide in ethylbenzene<sup>2</sup> (40:60 % w/w, SADT for a heat loss of  $60\text{ mW/K}\cdot\text{kg}$  should be  $90\text{ }^{\circ}\text{C}$ ), or any of the substances from the example of results tables in chapter 28.

<sup>2</sup> Reference: Dürstein S., Kappler C., Neuhaus I., Malow M., Michael-Schulz H., Gödde M., 2016, Modell-based prediction of the adiabatic induction period and SADT of dicumyl peroxide solution and comparison to large-scale experiments performed using 216.5-liter barrels in the H.1 test, *Chemical Engineering Transactions*, 48, 475-480.

## 28.4.2.3.2 Test procedure

The test procedure is as follows:

- (a) Fill the Dewar vessel/test cell with the weighed sample, including a representative amount of packaging material (if necessary), and place it in the vessel holder of the oven;
- (b) Start the temperature monitoring and then increase the sample temperature to a pre-set temperature at which detectable self-heating may occur. The specific heat of the substance can be calculated from the temperature rise, heating time and heating power, or be determined by any suitable calorimetric test method beforehand;
- (c) Heat the sample to the set temperature, maintain the oven temperature and monitor the sample temperature. If no temperature rise due to self-heating is observed after temperature equilibration of the system (e.g. 24 h for the open system), increase the temperature by 5 °C. Repeat this procedure until self-heating is detected;

For the closed version the apparatus can be heated with < 0.5 W/kg until self-heating is detected. The heating power per unit mass should remain below the sensitivity for self-heating detection of the test equipment or autoclave;

- (d) When self-heating is detected, the sample is allowed to heat up under adiabatic conditions to a pre-set temperature, at which point the cooling system is activated or the oven temperature has reached its limit;

For the open version this temperature should be set so that the rate of heat generation does not exceed the cooling capacity of the system;

For the closed version this temperature is usually a pre-set maximum oven temperature. The sample may exceed this temperature under non-adiabatic conditions.

28.4.2.4 *Test criteria and method of assessing results*

28.4.2.4.1 Calculate the rate of temperature drop, A (K/h), of the Dewar vessel at the different temperatures used in the calibration procedure. Plot a graph through these values in order to allow determination of the rate of temperature drop at any temperature.

28.4.2.4.2 Calculate the heat capacity, H (J/K), of the Dewar vessel using the formula:

$$H = \frac{3600 \times E_1}{A + B} - (M_1 \times C_{p1})$$

where:

$E_1$	=	power applied to the internal heater (W)
$A$	=	rate of temperature drop at the temperature of calculation (K/h)
$B$	=	slope of the curve on internal heating (validation substance) at the temperature of calculation (K/h)
$M_1$	=	mass of validation substance (kg)
$C_{p1}$	=	specific heat of validation substance (J/K·kg)

28.4.2.4.3 Determine the heat loss, K (W), using:

$$K = \frac{A \times (H + M_1 \times C_{p1})}{3600}$$

at each desired temperature and draw a graph through these values.

28.4.2.4.4 Calculate the specific heat,  $C_{p_2}$  (J/K·kg) of the substance using:

$$C_{p_2} = \frac{3600 \times (E_2 + K)}{C \times M_2} - \frac{H}{M_2}$$

where:  $E_2$  = power applied to the internal heater (W)  
 $C$  = slope of the curve on internal heating (sample) at the temperature of calculation (K/h)  
 $M_2$  = mass of sample (kg)

28.4.2.4.5 Calculate the heat generation,  $Q_T$  (W/kg), of the substance at intervals of 5 °C using the following formula for each temperature:

$$Q_T = \frac{(M_2 \times C_{p_2} + H) \times \frac{D}{3600} - K}{M_2}$$

where:  $D$  = slope of the curve during the self-heating at the temperature of calculation (K/h)

28.4.2.4.6 Plot the calculated rates of heat generation per unit of mass ( $Q_T$ ) as a function of the temperature in a graph with linear scales and draw the best-fit curve through the plotted points. Determine the heat losses per unit of mass,  $L$  (W/K·kg) of the specific package, IBC or tank (see 28.3.5). Draw a straight line of gradient  $L$  tangential to the heat generation curve. The intersection of the straight line and the abscissa is the critical ambient temperature i.e. the highest temperature at which the substance as packaged does not show self-accelerating decomposition. The SADT or SAPT is the critical ambient temperature (°C) rounded to the next higher multiple of 5 °C. An example is given in Figure 28.4.2.2.

28.4.2.5 *Examples of results*

Substance	Mass (kg)	Packaging	Heat loss per unit mass (mW/K·kg)	SADT/SAPT (°C)
Azodicarbonamide <sup>a</sup>	30	1G	100	> 75
tert-Butyl peroxybenzoate <sup>a</sup>	25	6HG2	70	55
tert-Butyl peroxy-2-ethylhexanoate <sup>a</sup>	25	6HG2	70	40
tert-Butyl peroxy-pivalate <sup>a</sup>	25	6HG2	70	25
N-Vinylformamide	1000	31H1	33	55

<sup>a</sup> These historical examples were determined using heat losses that are higher than those currently recommended for classification purposes (see table 28.4).

**Figure 28.4.2.1: Adiabatic storage test**

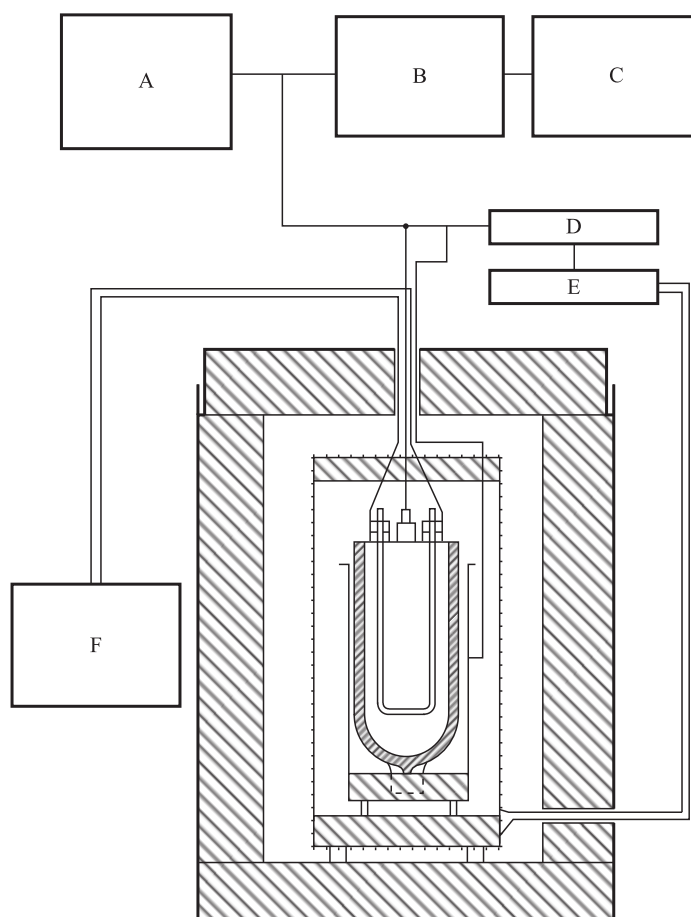

- 
- |   |                         |
|---|-------------------------|
| (A) Multi-point recorder and temperature controller (10 mV) | (B) External zero set   |
| (C) Recorder set for greatest accuracy                      | (D) Control             |
| (E) Relay   | (F) Internal pre-heater |
-

Figure 28.4.2.2: Example of determination of SADT or SAPT

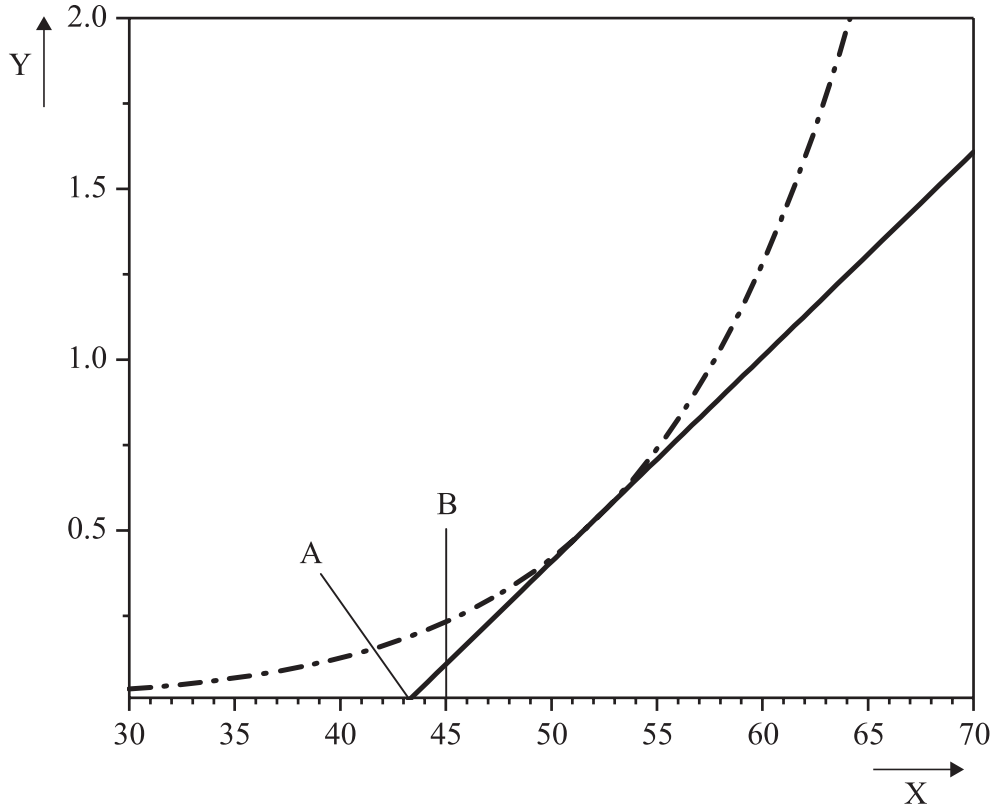

— · — ·	Heat generation curve	—	Heat loss curve $L = 0.06 \text{ W/K} \cdot \text{Kg}$
(A)	Critical ambient temperature (intercept of heat loss with the abscissa)	(B)	SADT or SAPT (critical ambient temperature rounded up to next higher multiple of $5 \text{ }^\circ\text{C}$ )
(X)	Temperature in $^\circ\text{C}$	(Y)	Heat flux in $\text{W/kg}$

### 28.4.3 *Test H.3: Isothermal storage test (IST)*

#### 28.4.3.1 *Introduction*

28.4.3.1.1 This method determines the rate of heat generation produced by reacting or decomposing substances as a function of time at constant temperature. The heat generation parameters obtained are used with the heat loss data relating to the package to determine the SADT or SAPT of a substance in its packaging. The method is appropriate for every type of packaging including IBCs and tanks. Some substances may show an increase in the rate of heat generation with increasing decomposition (e.g. due to autocatalysis or induced decomposition). This property is also taken into account by this test method.

28.4.3.1.2 The usually robust construction of readily available apparatus, the relatively small sample size and the well-defined operating conditions enable the test to be performed in an ordinary laboratory. The effects of a thermal explosion, e.g. fragmentation of the sample holder and generation of pressure, should be contained within the apparatus.

#### 28.4.3.2 *Apparatus and materials*

##### 28.4.3.2.1 Isothermal calorimetry (IC)

Appropriate isothermal calorimeters can be used. The equipment should be able to measure heat generation values of 1 mW/kg to 1500 mW/kg in a temperature range of -20 °C to 200 °C. The maximum error in the heat generation should be less than 5 %. The equipment should be capable of maintaining the temperature to within 0.2 °C of the set temperature. Sample mass of test material should be at least 200 mg. Closed pressure resistant sample holders should be used and the material of the sample holder should not have catalytic effect on the decomposition behaviour of the test substance. This can be achieved by selecting the appropriate materials for the sample holders or by an appropriate passivation method of the sample holders.

28.4.3.2.2 The sample holder is placed on or around heat flow meter. The amount of substance in the sample holder is at least 200 mg. The material of the holder should be compatible with the sample. If an external reference is used it should be handled identical to the sample.

28.4.3.2.3 The heat flow from the sample holder is continuously recorded as a function of time (differential measurement) by a recorder or computer.

#### 28.4.3.3 *Procedure*

##### 28.4.3.3.1 Calibration procedure

Before a measurement can be performed, the blank signal and the sensitivity of the heat flow meter need to be determined by the applicable calibration procedure for the equipment used covering the temperature range of the measurement.

##### 28.4.3.3.2 Test procedure

The test procedure is as follows:

- (a) Set the apparatus for the desired test temperature. The temperature selected should be sufficient to give a rate of heat generation between 5 mW to 1000 mW per kg of substance or for tanks a maximum heat generation rate between 1 and 100 mW/kg;
- (b) Fill the sample holder with the weighed sample and with a representative quantity of packaging material (if metal) and insert the holder into the apparatus;
- (c) Start monitoring the rate of heat production. The duration of each test depends on the test temperature and on the rate of heat production. The measuring time as given in Figure 28.4.3.1 can be used as guidance unless it leads to unrealistic measuring times

(e.g. greater than 1000 hours). These measuring times are given to achieve a certain degree of conversion of the substance in order to take auto-catalytic effects into account<sup>3</sup>;

- (d) At the end of the test the change in sample mass should be determined;
- (e) The test is repeated with new samples at temperature intervals of 5 °C so that there are five results with a maximum heat generation rate between 5 and 1000 mW/kg or for tanks a maximum heat generation rate between 1 and 100 mW/kg.

**Figure 28.4.3.1: Measuring period as a function of maximum heat generation measured**

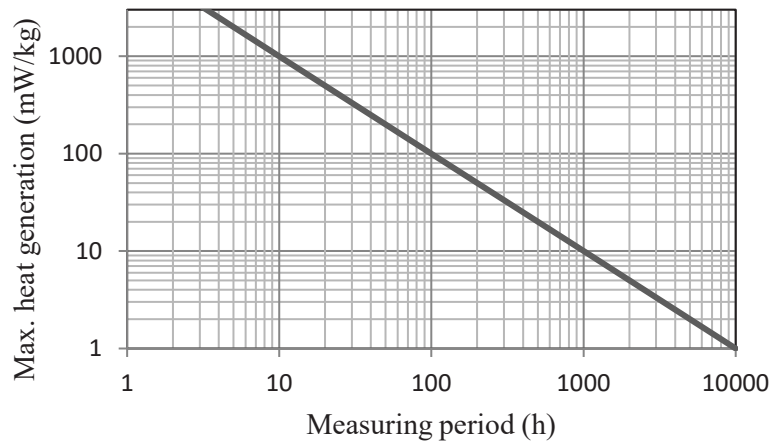

#### 28.4.3.4 Test criteria and method of assessing results

28.4.3.4.1 Plot the calculated maximum rate of heat generation per unit of mass as a function of the test temperature on a graph with linear scales and draw the best-fit curve through the plotted points. Determine the heat losses per unit of mass,  $L$  (W/K·kg) of the specific package, IBC or tank (see 28.3.5). Draw a straight line of gradient  $L$  tangential to the heat generation curve. The intersection of the straight line and the abscissa is the critical ambient temperature i.e. the highest temperature at which the substance as packaged does not show self-accelerating decomposition. The SADT or SAPT is the critical ambient temperature (°C) rounded to the next higher multiple of 5 °C. An example is given in Figure 28.4.3.2.

#### <sup>3</sup> References:

- 1) J. L. C. van Geel, *Investigations into Self-Ignition Hazard of Nitrate Ester Propellants*, Thesis, Technical University of Delft, The Netherlands, 1969.
- 2) Barendregt, R.B., *Thermal Investigation of Unstable Substances, Including a Comparison of Different Thermal Analytical Techniques*, Thesis, Technical University of Delft, The Netherlands, 1981.



28.4.3.5 *Examples of results*

Substance	Mass (kg)	Packaging	Heat loss per unit mass (mW/K·kg)	SADT/SAPT (°C)
Azodicarbonamide <sup>a</sup>	30	1G	100	> 75
tert-Butyl peroxybenzoate <sup>a</sup>	25	6HG2	70	55
tert-Butyl peroxy-2-ethylhexanoate <sup>a</sup>	25	6HG2	70	40
tert-Butyl peroxy-pivalate <sup>a</sup>	25	6HG2	70	25
2,5-Diethoxy-4-morpholinobenzenediazonium zinc chloride (90 %) <sup>a</sup>	25	1G	150	45
2,5-Diethoxy-4-morpholinobenzenediazonium tetrafluoroborate (97 %) <sup>a</sup>	25	1G	15	55
2,5-Diethoxy-4-(phenylsulphonyl)-benzenediazonium zinc chloride (67 %) <sup>a</sup>	25	1G	15	50
2-(N-ethoxycarbonyl-N-phenylamino)-3-methoxy-4-(N-methyl-N-cyclohexylamino)-benzenediazonium zinc chloride (62 %) <sup>a</sup>	25	1G	15	45
3-Methyl-4-(pyrrolidin-1-yl) benzenediazonium tetrafluoroborate (95 %) <sup>a</sup>	25	1G	15	55
Cumyl peroxyneodecanoate (75 %)	25	3H1	40	10
tert-Butyl peroxyneodecanoate	25	3H1	40	15
N-Vinylformamide	1000	31H1	33	55

<sup>a</sup> These historical examples were determined using heat losses that are higher than those currently recommended for classification purposes (see table 28.4).

Figure 28.4.3.2: Example of determination of SADT or SAPT

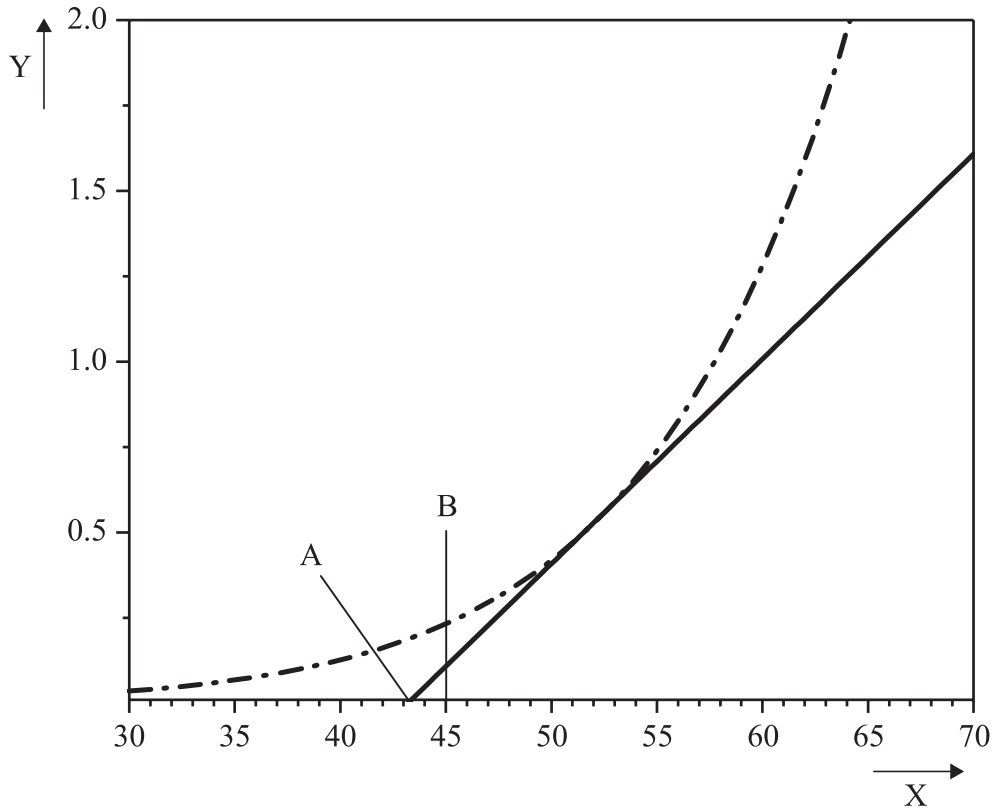

— · — ·	Heat generation curve	—	Heat loss curve $L = 0.06 \text{ W/K} \cdot \text{kg}$
(A)	Critical ambient temperature (intercept of heat loss with the abscissa)	(B)	SADT or SAPT (Critical ambient temperature rounded up to next higher multiple of $5 \text{ }^\circ\text{C}$ )
(X)	Temperature in $^\circ\text{C}$	(Y)	Heat flux in $\text{W/kg}$

## 28.4.4 *Test H.4: Heat accumulation storage test*

### 28.4.4.1 *Introduction*

28.4.4.1.1 This method determines the minimum constant air environment temperature at which thermally unstable substances undergo exothermic decomposition or polymerization at conditions representative of the substance when packaged. The method is based on the Semenov theory of thermal explosion i.e. the main resistance to heat flow is considered to be at the vessel walls. The method can be used for the determination of the SADT or SAPT of a liquid substance in its packaging, including IBCs and small tanks (up to 2 m<sup>3</sup>) as well as for a solid substance in its packaging up to 50 kg.

28.4.4.1.2 The effectiveness of the method depends on selecting a Dewar vessel with heat loss per unit mass characteristics similar to the package.

### 28.4.4.2 *Apparatus and materials*

28.4.4.2.1 The experimental equipment consists of a suitable test chamber, appropriate Dewar vessels with closures, temperature probes and measuring equipment.

28.4.4.2.2 ***The test should be performed in a test chamber capable of withstanding fire and overpressure and, preferably, should be fitted with a pressure relief system e.g. a blow out panel.*** The recording system should be housed in a separate observation area.

28.4.4.2.3 For tests at temperatures up to 75 °C, a double walled metal chamber (ca. 250 mm inner diameter, 320 mm outer diameter and 480 mm high, made from 1.5 mm to 2.0 mm thick stainless steel sheet) can be used with fluid from a temperature-controlled circulating bath passed between the walls at the desired temperature. The test chamber is loosely closed by an insulated lid (e.g. made from 10 mm thick polyvinyl chloride). The air temperature in the double walled metal chamber should be controlled so that the desired temperature for a liquid inert sample in the Dewar vessel can be maintained with a deviation of not more than ± 1 °C for up to 10 days. The air temperature in the double walled metal chamber and the sample temperature in the Dewar vessel should be measured and recorded.

28.4.4.2.4 Alternatively, and particularly for tests at temperatures above 75 °C, a thermostatically controlled drying oven (which may be fan-assisted) large enough to allow air circulation on all sides of the Dewar vessel may be used. The air temperature in the oven should be controlled so that the desired temperature for a liquid inert sample in the Dewar vessel can be maintained with a deviation of not more than ± 1 °C for up to 10 days. The air temperature in the oven and the sample temperature in the Dewar vessel should be measured and recorded. It is recommended that the door of the oven be fitted with a magnetic catch or replaced by a loosely fitting insulated cover. The oven may be protected by an appropriate steel liner and the Dewar vessel housed in a wire mesh cage.

28.4.4.2.5 For tests at sub-ambient temperatures, a double walled chamber (e.g. a freezer) of suitable size provided with a loose door or lid (e.g. with a magnetic closure) may be used. The temperature of the air in the chamber should be controlled to ± 1 °C of the set temperature. The air temperature in the chamber and the sample temperature in the Dewar vessel should be measured and recorded.

28.4.4.2.6 Dewar vessels, with their closure system, are used with heat loss characteristics which are representative of the maximum package size under investigation (see also table 28.4). The closure of the Dewar vessel should be made of inert material. Particularly for solids, cork or rubber bungs may be used. An example of a closure system for use with liquids with low or medium volatility and wetted solids is illustrated in Figure 28.4.4.1. Samples which are highly volatile at the test temperature should be tested in a pressure-tight vessel that is made of a material compatible with the sample and fitted with a pressure relief valve. The pressure vessel is placed in the Dewar vessel and the effect of the heat capacity of the metal vessel taken into account by calculation.

28.4.4.2.7 The heat loss characteristics of the system used, i.e. Dewar vessel and closure, should be established (see 28.3.6) prior to performance of the test. Small adjustments to the heat loss characteristics of

the Dewar vessel can be achieved by varying the closure system. In order to achieve the required level of sensitivity, Dewar vessels with sample capacities below 0.3 litres should not be used.

28.4.4.2.8 Dewar vessels with a volume of 300 – 500 ml, filled at 80 % with a liquid substance, with a heat loss as given in Table 28.4 should be used. For larger packages, IBCs or small tanks, larger Dewar vessels with lower heat losses per unit mass should be used (see Table 28.4).

#### 28.4.4.3 *Procedure*

28.4.4.3.1 Set the test chamber at the selected storage temperature. Fill the Dewar vessel, to 80 % of its capacity, with the substance to be tested and note the mass of the sample. Solids should be moderately compressed. In case of a cylindrical Dewar vessel, the temperature probe is inserted centrally 1/3 of the inner height of the Dewar from the bottom of the Dewar vessel. Seal the lid of the Dewar in place and insert the Dewar vessel in the test chamber, connect the temperature recording system and close the test chamber.

28.4.4.3.2 The sample is heated and the temperature of the sample and test chamber continuously monitored. The time is noted at which the sample temperature reaches a temperature 2 °C below the test chamber temperature. The test is then continued for a further seven days or until the sample temperature rises to 6 °C or more above the test chamber temperature, whichever occurs sooner.

28.4.4.3.3 If the sample survives, cool and remove it from the test chamber and carefully dispose of it as soon as possible. The percentage mass loss and change in composition may be determined.

28.4.4.3.4 If the substance is being tested to determine if temperature control is necessary, perform sufficient tests, in steps of 5 °C using fresh samples, to determine the SADT or SAPT to the nearest 5 °C or to determine if the SADT or SAPT is equal to or less than the applicable temperature specified in Table 28.2. If the substance is being tested to determine if it meets the SADT criterion for a self-reactive substance, perform sufficient tests to determine if the SADT for a 50 kg package is 75 °C or less. If the substance is being tested to determine if it meets the SAPT criterion for a polymerizing substance, perform sufficient tests to determine if the SAPT in the packaging as used is 75 °C or less.

#### 28.4.4.4 *Test criteria and method of assessing results*

28.4.4.4.1 The SADT or SAPT is reported as the lowest chamber temperature at which the sample temperature exceeds the chamber temperature by 6 °C or more within the seven days testing time frame (see 28.4.4.3.2). If the sample temperature does not exceed the chamber temperature by 6 °C or more in any test, the SADT or SAPT is recorded as being greater than the highest storage temperature used.

28.4.4.5 *Examples of results*

Substance	Sample mass (kg)	Dewar heat loss (mW/K·kg)	SADT/SAPT (°C)
Azodicarbonamide <sup>c</sup>	0.28	74	> 75
Azodicarbonamide, 90 % with 10 % activator <sup>c</sup>	0.21	70	55
2,2'-Azodi(isobutyronitrile)	0.28	27	50
Benzene-1,3-disulphohydrazide, 50 % <sup>c</sup>	0.52	81	70
tert-Butyl hydroperoxide, 80 % with 12 % di-tert-butyl peroxide <sup>c</sup>	0.30	72	100 <sup>a</sup>
tert-Butyl peroxyneodecanoate, 40 % <sup>c</sup>	0.42	65	25
tert-Butyl peroxy-3,5,5-trimethylhexanoate <sup>c</sup>	0.38	79	60
Dibenzoyl peroxide, 50 % <sup>c</sup>	0.25	91	60
Di-(4-tert-butylcyclohexyl) peroxydicarbonate <sup>c</sup>	0.19	79	45
2,2-Di-(tert-butylperoxy)butane, 50 % <sup>c</sup>	0.31	88	80
Di-(2-ethylhexyl) peroxydicarbonate <sup>c</sup>	0.39	64	0
2,5-Diethoxy-4-morpholinobenzenediazonium zinc chloride (66 %) <sup>c</sup>	0.25	58	45
Diisotridecyl peroxydicarbonate <sup>c</sup>	0.38	80	10
Peroxyacetic acid, 15 %, with 14 % hydrogen peroxide (type F) <sup>c</sup>	1.00	33	> 50 <sup>b</sup>
Dilauroyl peroxide, technically pure	0.16	26	50
Didecanoyl peroxide technically pure	0.20	28	40
N-Vinylformamide	0.40	33	55

<sup>a</sup> In a pressure vessel contained with a 2 litres Dewar vessel.

<sup>b</sup> In a spherical, 1 litre Dewar vessel.

<sup>c</sup> These historical examples were determined using heat losses that are higher than those currently recommended for classification purposes (see Table 28.4).

**Figure 28.4.4.1: Dewar vessel with closure for testing liquids and wetted solids**

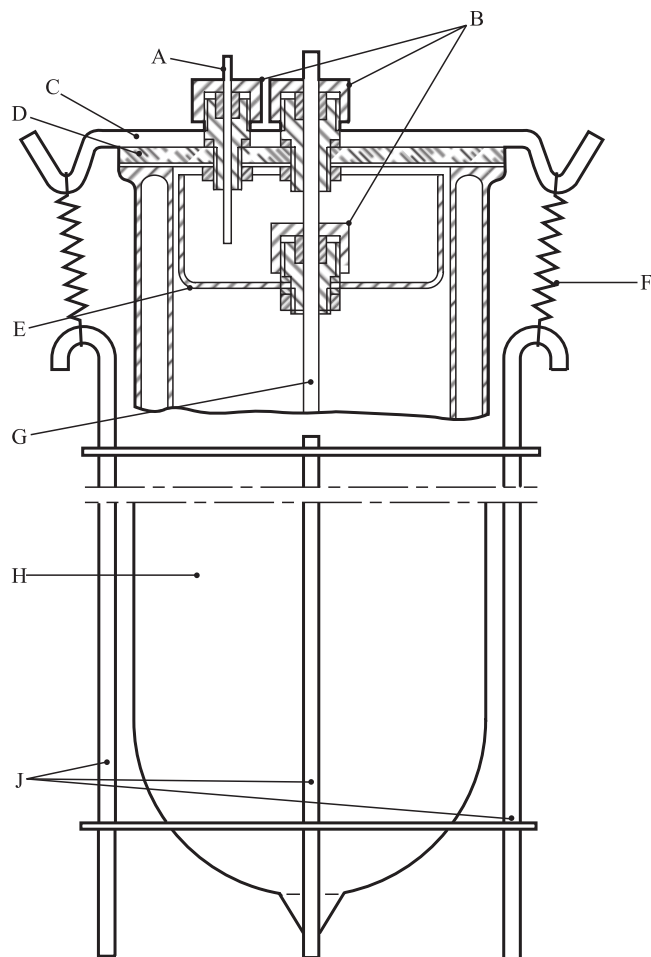

- 
- |                            |  |
|----------------------------|--|
| (A) PTFE capillary tube    | (B) Special screw fittings (PTFE or Al) with O-ring seal |
| (C) Metal strip            | (D) Glass lid  |
| (E) Glass beaker base      | (F) Spring   |
| (G) Glass protective tube  | (H) Dewar vessel   |
| (J) Steel retaining device |  |
- 

”

## Section 33

33.2.4.2 In the first sentence, insert “inner” before “width”.

Figure 33.2.4.1 Replace inset A with the following figure:

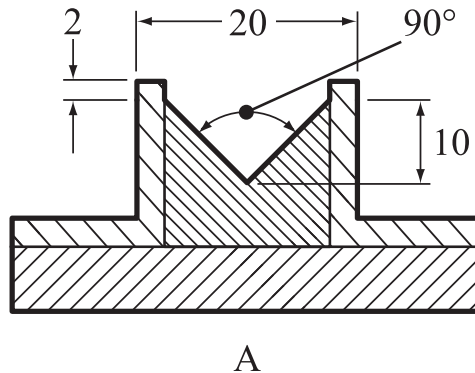

## Section 34

34.4.1.2.6 and 34.4.3.2.3 At the end, insert a new note to read as follows:

**“NOTE:** *In the case of a substance coated to reduce or suppress its oxidizing properties with a significant content (> 10 % by mass) of particles less than 500 µm, two sets of tests should be conducted: tests conducted with the substance as presented and tests conducted with particles less than 500 µm that were obtained from sieving the substance as presented. The substance should not be ground before sieving or testing. The final classification should be based on the test results with the most stringent classification.”*

## Section 37

37.4.1 Delete.

37.4.1.1 (former) Renumber as 37.4.1.

37.4.1.1 Insert the following new 37.4.1.1:

“37.4.1.1 *Introduction*

This test is used for determining the corrosive properties of liquids and solids that may become liquid as a substance corrosive to metal, packing group III/category 1.”

Renumber paragraphs 37.4.2, 37.4.3, 37.4.4, 37.4.4.1 and 37.4.4.2 as 37.4.1.2, 37.4.1.3, 37.4.1.4, 37.4.1.4.1 and 37.4.1.4.2. Renumber figures 37.4.2.1 and 37.4.2.2 as 37.4.1.1 and 37.4.1.2 respectively and update cross references in section 37.4 accordingly. Renumber tables 37.4.4.1 and 37.4.4.2 as 37.4.1.1 and 37.4.1.2 respectively.

37.4.2 (Renumbered 37.4.1.2) (b) Amend to read as follows:

“(b) Steel type S235JR+CR (1.0037, resp. St 37-2), S275J2G3+CR (1.0144, resp. St 44-3), ISO 3574, Unified Numbering System (UNS) G10200 or SAE 1020.”

## Section 38

38.3.3 (d) In the last paragraph, after “another battery”, add “, vehicle,”.

38.3.3 (g) At the end, add the following new paragraphs:

“For an assembled battery not equipped with overcharge protection that is designed for use only as a component in another battery, in equipment, or in a vehicle, which affords such protection:

- the overcharge protection shall be verified at the battery, equipment or vehicle level, as appropriate, and
- the use of charging systems without overcharge protection shall be prevented through a physical system or process controls.”

38.3.5 Amend sub-paragraph (j) of the test summary to read as follows:

“(j) Name and title of responsible person as an indication of the validity of information provided.”

## **Section 41**

41.1.3 Add a new paragraph 41.1.3 to read as follows:

“41.1.3 The portable tank or MEGC being subjected to the dynamic longitudinal impact test shall be dry prior to beginning the impact testing. If the facility or witnessing agency’s ability to identify potential sources of leakage is negatively impacted by weather conditions such as snow or rain that develop during testing, the impact testing shall be terminated. Impact testing shall only resume once the portable tank or MEGC is dry, and the snow or rain have stopped.”

## **Section 51**

51.2.1 In footnote 1, amend the first sentence to read: “Explosives of GHS Chapter 2.1 that are considered too sensitive to assign a division can also be stabilized by desensitization and consequently may be classified as desensitized explosives, provided all criteria of GHS Chapter 2.17 are met.”.

---