

Advanced axles in trailers

New technologies to reduce CO2 emissions for vehicle combinations

UNECE, 10th GRVA, May 2021



Advanced axles in trailers

Road transport sector and Climate protection

- European Green Deal: EU's commitment to reaching climate neutrality by 2050 and to raise the 2030 greenhouse gas emission (GHGE) reduction target to at least 55% compared to 1990

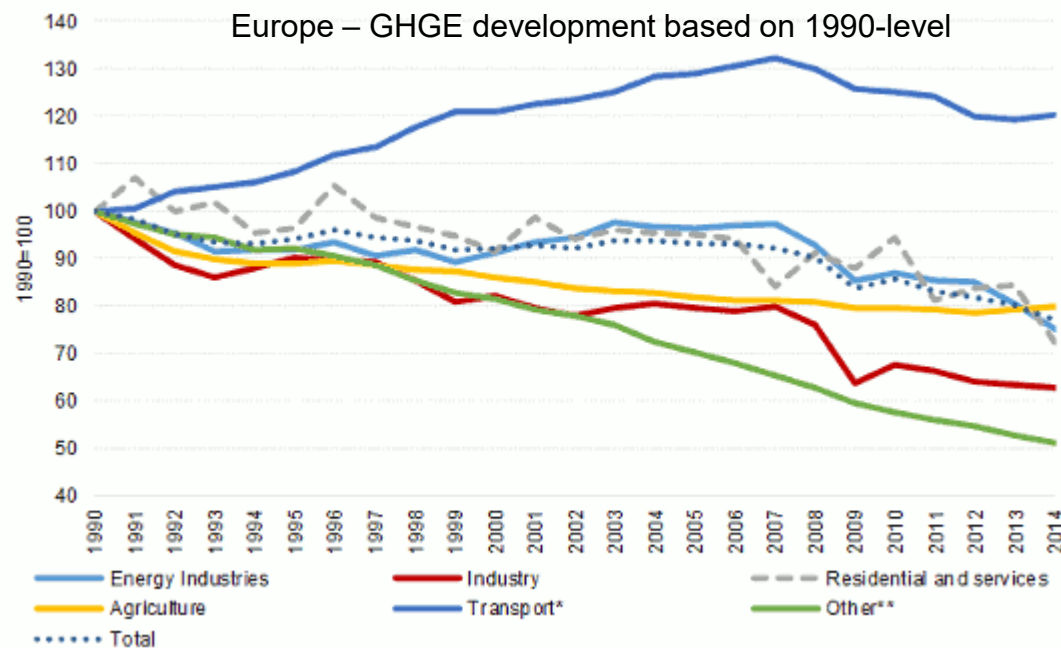

- GHGE in Europeans transport sector increased in the last decades due to growing transport capacities
- Transport represents almost a quarter of Europe's GHGE whereof Heavy-duty vehicles – trucks and buses – are responsible for about 5% of total EU emissions

Source: https://ec.europa.eu/clima/policies/transport_en

Advanced axles in trailers

Road transport sector and Climate protection



Europe

(EU) 2019/1242 – CO2 Reduction targets for N2/N3 vehicles **-15% in 2025** and **-30% in 2030** compared to 2019/2020

→ Procedure for a **CO2 certification of trailers** is under development and shall be finalised until end of 2021

→ Currently defined parameters to reduce CO2 emissions at the trailer are:

- Weight
- Rolling resistance
- Air drag

} Improvements are limited due to restricted masses & dimensions and intended use of the trailer → **high pressure to invest in advanced technologies beyond these parameters**

Advanced axles in trailers

New technologies provided by suppliers and trailer industry

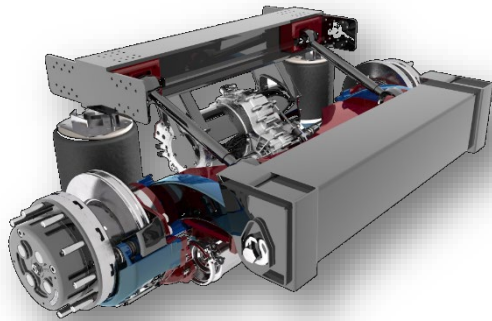

TrailerDynamics – Electric axle



ZFWABCO – Driven trailer concept



BOSCH



Schmitz Cargobull – Electrified cooling unit with energy provided by trailer axles



SAF Holland – Electric axles



Krone – Recuperation by trailer axles

Advanced axles in trailers

Reasons to propel trailers

Standard tractor/semi-trailer combination

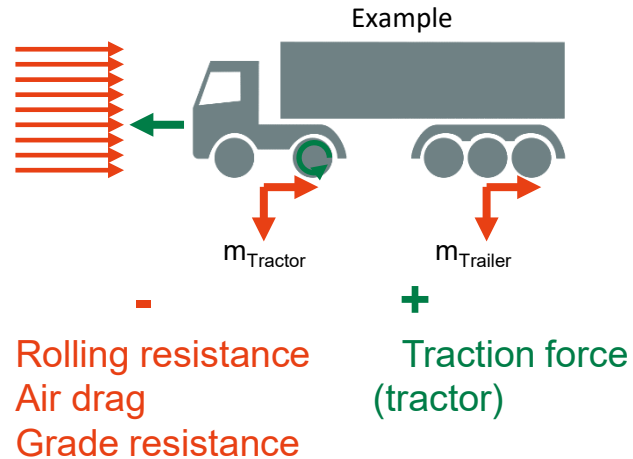

- Traction force is provided by tractor **only** and is transmitted to tractor axle(s)
- Trailer does not support the tractor in driving conditions

Tractor/semi-trailer combination with driven trailer axles

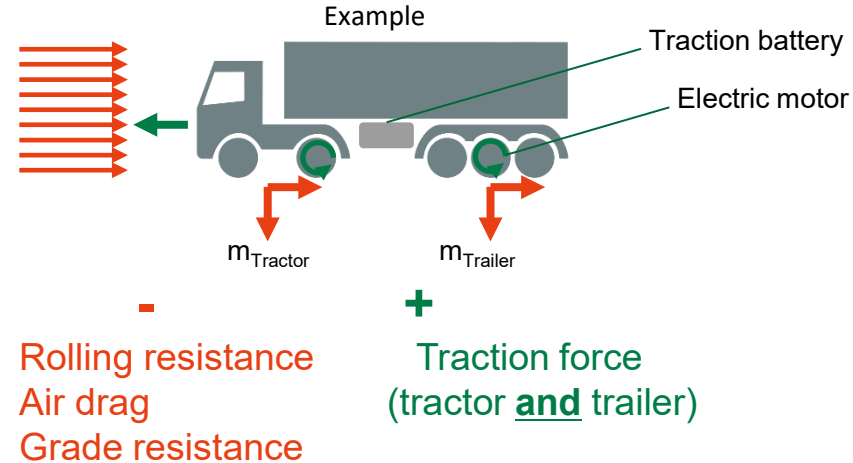

- Main traction force is provided by tractor and is transmitted to tractor axle(s) but **in addition** at least one trailer axle **is driven independent** from power source of tractor

Advanced axles in trailers

Applications for potential CO2 savings based on driven axles

Different use cases for advanced axles in trailers:

- Support start/stop manoeuvres of tractor by driven axle(s) in trailers
- Acceleration and Recuperation during driving
- “Hybrid” propulsion concept for the vehicle combination
- Separate energy support for auxiliary units by an electric axle (e.g. electric cooling units, heating devices ...)

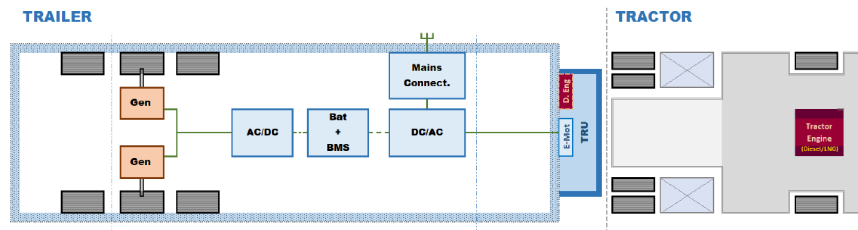

- Independent energy support for the trailer during standstill/parking
- “Vehicle to grid” applications

Recuperation

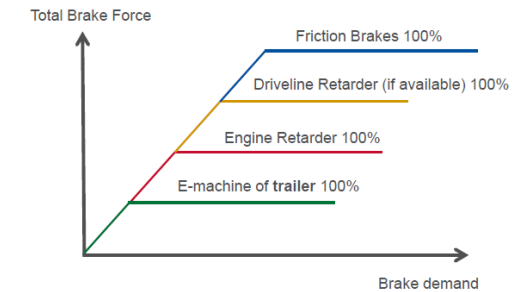

Acceleration

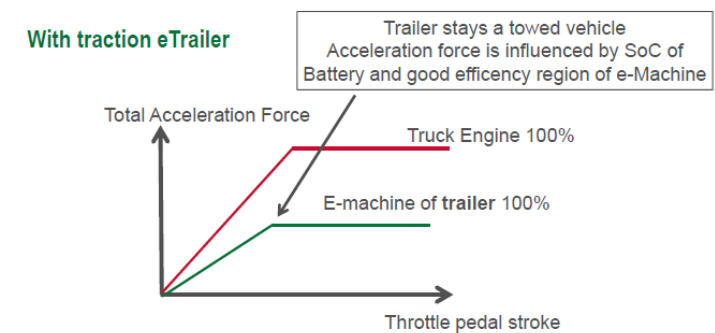

Advanced axles in trailers

Premises



1. The trailer remains in the towed condition (except for the starting aid and except pushing forces that result from the dynamic conditions of the motor vehicle and trailer while driving)
2. Longitudinal dynamics of the motor vehicle influences the working mode of a driven trailer (e.g. for recuperation and interaction with retarder etc.) depending on the capabilities of the driven trailer
3. Motor vehicle and heavy trailers in a vehicle combination may communicate with each other (depending on the trailer category and driving modes)
4. Operating modes except for the starting aid are not subject to any speed restrictions, the speed range of the trailer propulsion can be identical to the speed range of the motor vehicle
5. The vehicle combination must remain separable, i.e. Motor vehicles and trailers each have their own drive components
6. Driven axles in trailers can have any type of propulsion (electrical, hydraulic ...) - specifications for this must be formulated in a technology-neutral manner

Advanced axles in trailers

Today's bottleneck in the definition of trailers (RE.3/SR.1)

Paragraph 1.5:

“1.5. "Trailer" means any **non-self propelled** vehicle, which is designed and constructed to be towed by a power driven vehicle and includes semi-trailers.”

A trailer with a driven axle has a kind of propulsion independent from the motor vehicle and may self propelled but furthermore towed

Paragraph 1.8:

“1.8. "Road tractor" means road motor vehicle designed, exclusively or primarily, to haul other road vehicles **which are not power-driven** (mainly semi-trailers).”

A trailer with a driven axle is power-driven although not with the same power as the motor vehicle

Paragraphs 2.4.5.1 to 2.4.5.3:

“2.4.5.1. "Semi-trailer": A towed vehicle, in which the axle(s) is (are) positioned behind the centre of gravity of the vehicle (when uniformly loaded), and which is equipped with a connecting device permitting horizontal and vertical forces to be transmitted to the towing vehicle. One or more of the axles may be driven **by the towing vehicle**.

A driven axle in a trailer (e.g. electric axles) operates independent from the towing vehicle as a separate device without force transmission from the tractors engine.

“2.4.5.2. and 2.4.5.3. ... similar to 2.4.5.1.

Advanced axles in trailers

Next steps



- First presentation done in UNECE GRSG (April 2021)

To do

- GRSG: Check the vehicle definitions and propose some additional wording
- GRSP: Amendment of UN R100 is needed for a kind of a electric axle in a trailer
 - Check defined requirements and review possible use cases for the trailer
- **GRVA: Check for further amendments in other UN regulations (e.g. UN R13 ...)**

→ CLCCR would appreciate the opinion of delegates in UNECE



CLCCR
International Association of the
Body and Trailer Building Industry

Founded in 1961, CLCCR is the International Association of the Body and trailer building industry. CLCCR advocates the various interests of trailer manufacturers, body builders and non-captive OEM Bus & Coach builders.

- It functions as an international forum, through which its members discuss issues of common interest and develop mutual positions,
- It offers a liaison between its members and the different international and European organizations,
- It represents approved CLCCR positions to different international and European organizations,
- It provides information services to its members and interested parties.