

2 November 2020

Agreement

Concerning the Adoption of Harmonized Technical United Nations Regulations for Wheeled Vehicles, Equipment and Parts which can be Fitted and/or be Used on Wheeled Vehicles and the Conditions for Reciprocal Recognition of Approvals Granted on the Basis of these United Nations Regulations*

(Revision 3, including the amendments which entered into force on 14 September 2017)

Addendum 50 – UN Regulation No. 51

Revision 3 - Amendment 6

Supplement 6 to the 03 series of amendments – Date of entry into force: 25 September 2020

Uniform provisions concerning the approval of motor vehicles having at least four wheels with regard to their sound emissions

This document is meant purely as documentation tool. The authentic and legal binding texts is: ECE/TRANS/WP.29/2020/4.



UNITED NATIONS

* Former titles of the Agreement:
Agreement concerning the Adoption of Uniform Conditions of Approval and Reciprocal Recognition of Approval for Motor Vehicle Equipment and Parts, done at Geneva on 20 March 1958 (original version);
Agreement concerning the Adoption of Uniform Technical Prescriptions for Wheeled Vehicles, Equipment and Parts which can be Fitted and/or be Used on Wheeled Vehicles and the Conditions for Reciprocal Recognition of Approvals Granted on the Basis of these Prescriptions, done at Geneva on 5 October 1995 (Revision 2).



Paragraph 2.11.1., amend to read:

"2.11.1. In the case of vehicles of categories M₁, N₁ and M₂ < 3,500 kg technically permissible maximum laden mass:

- (a) For front engine vehicles: the front end of the vehicle;
- (b) For mid-engine vehicles: the centre of the vehicle;
- (c) For rear engine vehicles: the rear end of the vehicle.

For vehicles having multiple propulsion sources, the reference point is determined by the position of the propulsion source having the highest power. If there are multiple propulsion sources of equivalent power, then the position of the most forward propulsion source shall prevail."

Paragraph 2.24., Table of symbols, amend to read:

"2.24. Table of Symbols

...

gear ratio i	—	Annex 3	3.1.2.1.4.1.	gear ratio which provides an acceleration within the 5 per cent tolerance of the reference acceleration a_{wot_ref} or greater than the reference acceleration a_{wot_ref}
gear ratio i+1	—	Annex 3	3.1.2.1.4.1.	second of two gear ratios, with an acceleration lower than gear ratio i
gear ratio i+2, i+3, ...	—	Annex 3	3.1.2.1.4.1.	gear ratios selectable for the pass-by test of Annex 3, if gear ratio i and gear ratio i+1 exceed an acceleration of 2.0 m/s ²
k	—	Annex 3	3.1.2.1.4.1.	gear ratio weighting factor; value to be reported and used for calculations to the second decimal place

..."

Paragraph 2.26., amend to read:

"2.26. Stable acceleration

For the purpose of this Regulation, three conditions are defined for stable acceleration.

2.26.1. "Stable acceleration" applicable to all vehicles subject to this Regulation for low engine speed conditions, which eliminates power train reactions such as bumping and jerking.

2.26.2. "Stable acceleration" applicable to vehicles of category M₁, N₁ and M₂ < 3,500 kg technically permissible maximum laden mass avoids acceleration delays in acceleration due to engine control application, at the moment when the acceleration unit is depressed. This is typically ensured by using pre-acceleration.

2.26.3. "Stable acceleration" for the purpose of Annex 7 is based on the assumption of a constant acceleration over the complete measurement distance between AA' and BB' plus the vehicle length."

Insert a new paragraph 11.12., to read:

"11.12. Until 12 months after the date of entry into force of the Supplement 6, it shall not apply to extensions of existing approvals, originally granted prior to the date of entry into force of Supplement 6."

Annex 1, Appendix,

Paragraph 2.1., amend to read:

- "2.1. Sound level of moving vehicle (Annex 3): dB(A)
2.1.1. Selected mode for tests of the vehicle in motion:"

Paragraph 2.2., amend to read:

- "2.2. Sound level of stationary vehicle: dB(A) at min⁻¹ in mode¹
Sound level of stationary vehicle: dB(A) at min⁻¹ in mode¹
Sound level of stationary vehicle: dB(A) at min⁻¹ in mode¹
Sound level of stationary vehicle: dB(A) at min⁻¹ in mode¹
Sound level of stationary vehicle: dB(A) at min⁻¹ in mode¹"

Annex 3

Paragraph 3.1.2.1., last indent, replace 3.1.2.1.4.1.(e) with 3.1.2.1.4.1.(d).

Paragraph 3.1.2.1.1., amend to read:

- "3.1.2.1.1. Power to mass ratio index (PMR)

PMR is defined as follows:

$PMR = (P_n / m_{ro}) * 1000$ kg/kW, where P_n is measured in kW and m_{ro} is measured in kg and defined according to paragraph 2.4. of the main body.

If two or more sources of propulsive power operate at the conditions of test specified in paragraph 3.1.2.1 of Annex 3 to this Regulation, the total engine net power, P_n , shall be the arithmetic sum of parallel propulsive engines on the vehicle. Applicable parallel propulsive engines are those power sources which provide forward motion to the vehicle in combination at the conditions of test specified in paragraph 3.1.2.1. of Annex 3 to this Regulation. Specified power for non-combustion engines shall be the power stated by the manufacturer.

The PMR with no dimension is used for the calculation of acceleration."

Paragraph 3.1.2.1.4.1., amend to read:

- "3.1.2.1.4.1. Vehicles with manual transmission, automatic transmissions, adaptive transmissions or CVTs tested with locked gear ratios

The following conditions for selection of gear ratios are possible:

- (a) If one specific gear ratio gives an acceleration in a tolerance band of ± 5 per cent of the reference acceleration $a_{wot\ ref}$, not exceeding 2.0 m/s², test with that gear ratio;
(b) If none of the gear ratios give the required acceleration, then choose a gear ratio i , with an acceleration higher and a gear ratio $i+1$, with an acceleration lower than the reference acceleration. If the acceleration value in gear ratio i does not exceed 2.0 m/s², use both gear ratios for the test. The weighting ratio in relation to the reference acceleration $a_{wot\ ref}$ is calculated by:

$$k = (a_{wot\ ref} - a_{wot\ (i+1)}) / (a_{wot\ (i)} - a_{wot\ (i+1)})$$

¹ If applicable

- (c) If the acceleration value of gear ratio i exceeds 2.0 m/s^2 , the first gear ratio shall be used that gives an acceleration below 2.0 m/s^2 unless gear ratio $i+1$ (or $i+2$, or $i+3$ or ...) provides acceleration less than a_{urban} . In this case, two gears, i and $i+1$ (or $i+2$, or $i+3$ or ...) shall be used, including the gear i with acceleration exceeding 2.0 m/s^2 . In other cases, no other gear shall be used. The achieved acceleration $a_{\text{wot test}}$ during the test shall be used for the calculation of the part power factor k_P instead of $a_{\text{wot ref}}$;
- (d) If rated engine speed is exceeded in a gear ratio i before the vehicle passes BB' the next higher gear $i+1$ shall be used. If the next higher gear $i+1$ results in an acceleration below a_{urban} , the vehicle test speed, v_{test} , in the gear ratio i shall be reduced by 2.5 km/h and the gear ratio selection shall proceed as specified by the options given in this paragraph. In no case shall the vehicle test speed be reduced below 40 km/h ;
- If the rated engine speed is exceeded in gear ratio i before the vehicle passes BB' and the vehicle test speed is equal to 40 km/h , the higher gear ratio $i+1$ is allowed even if $a_{\text{wot test}}$ does not exceed a_{urban} ;
- The vehicle test speed in the higher gear ratio $i+1$ shall be 50 km/h ;
- (e) If no gear ratio is available with an acceleration below 2.0 m/s^2 , the manufacturer shall, if possible take measures to avoid an acceleration value $a_{\text{wot test}}$ greater than 2.0 m/s^2 .

Table 1 in Appendix to Annex 3 provides examples for valid measures to control the downshift of gears or to avoid accelerations beyond 2.0 m/s^2 . Any measure used by manufacturer for the above-mentioned purposes shall be documented in the test report."

Paragraph 3.1.2.2., amend to read:

"3.1.2.2. Vehicles of categories $M_2 > 3,500 \text{ kg}$ technically permissible maximum laden mass, M_3 , N_2 , N_3 :

[...]

When the reference point passes line BB', the engine speed $n_{BB'}$ shall be between 70 and 74 per cent of speed S , at which the engine develops its rated maximum net power, and the vehicle speed shall be $35 \text{ km/h} \pm 5 \text{ km/h}$. Between line AA' and line BB' a stable acceleration condition according to definition 2.26.1. shall be ensured.

Target conditions of category M_3 , N_3 :

When the reference point passes line BB', the engine speed $n_{BB'}$ shall be between 85 and 89 per cent of speed S , at which the engine develops its rated maximum net power, and the vehicle speed shall be $35 \text{ km/h} \pm 5 \text{ km/h}$. Between line AA' and line BB' a stable acceleration condition according to definition 2.26.1. shall be ensured."

Paragraph 3.1.2.2.1.1., amend to read:

"3.1.2.2.1.1. Manual transmission, automatic transmissions, adaptive transmissions or transmissions with continuously variable gear ratios (CVTs) tested with locked gear ratios

Stable acceleration condition according to definition 2.26.1. shall be ensured. The gear choice is determined by the target conditions.

The following conditions for fulfilling the target conditions in paragraph 3.1.2.2. of Annex 3 to this Regulation are possible:

- (a) If one gear choice fulfils both target conditions for the rotational engine speed $n_{\text{target BB'}}$ and for the vehicle speed $v_{\text{target BB'}}$, test with that gear;

- (b) If more than one gear choice fulfils both target conditions for the rotational engine speed $n_{\text{target BB}'}$ and for the vehicle speed $v_{\text{target BB}'}$, test in gear i that gives velocity $v_{\text{BB}' \text{ gear } i}$ closest to 35 km/h;
- (c) If two gear choices fulfil both target conditions for the rotational engine speed $n_{\text{target BB}'}$ and for the vehicle speed $v_{\text{target BB}'}$, and fulfil the following condition.

$$(v_{\text{target BB}' } - v_{\text{BB}' \text{ gear } i}) = (v_{\text{BB}' \text{ gear } i+1} - v_{\text{target BB}'})$$

then both gears are taken for further calculation of L_{urban} ;

- (d) If one gear choice fulfils the target condition for the rotational engine speed $n_{\text{target BB}'}$ but not the target condition for the vehicle speed $v_{\text{target BB}'}$, use two gears, gear_x and gear_y. The target conditions for the vehicle speed for these two gears are as follows:

gear_x

$$25 \text{ km/h} \leq v_{\text{BB}'x} \leq 30 \text{ km/h}$$

and

gear_y

$$40 \text{ km/h} \leq v_{\text{BB}'y} \leq 45 \text{ km/h}$$

Both gears, gear_x and gear_y shall fulfil the target rotational engine speed $n_{\text{target BB}'}$. Both gears shall be used for further calculation of L_{urban} .

If only one of the gears fulfils the target rotational engine speed, $n_{\text{target BB}'}$, test with that gear. This gear shall be used for further calculation of L_{urban} ;

- (e) If none of the two gears fulfils the target rotational engine speed $n_{\text{target BB}'}$ under condition d) then condition f) shall be chosen;
- (f) If no gear choice fulfils the target rotational engine speed choose the gear that fulfils the target vehicle velocity $v_{\text{target BB}'}$ and is closest to the target rotational engine speed $n_{\text{target BB}'}$, but not higher than $n_{\text{target BB}'}$.

$$v_{\text{BB}' \text{ gear } i} = v_{\text{target BB}'}$$

$$n_{\text{BB}' \text{ gear } i} \leq n_{\text{target BB}'}$$

A stable acceleration condition according to definition 2.26.1. shall be ensured. If such a stable acceleration cannot be ensured in a gear, this gear shall be disregarded. In all conditions, the rated engine speed shall not be exceeded while the reference point of the vehicle is in the measurement zone. If the rated engine speed is exceeded within the measurement zone, this gear shall be disregarded."

Paragraph 3.1.3., amend to read:

"3.1.3. Interpretation of results
For vehicles of categories M_1 and M_2 having a maximum authorized mass not exceeding 3,500 kg, and category N_1 the maximum A-weighted sound pressure level indicated during each passage of the vehicle according to paragraphs 3.1.2.1.5. and 3.1.2.1.6. shall be rounded to the first significant digit after the decimal place (e.g. XX,X)."

Paragraph 3.2.5.3., amend to read:

"3.2.5.3. Measuring of noise in proximity to the exhaust (see appendix of Annex 3, Figure 3a)."

Paragraph 3.2.5.3.1.2., amend to read:

"3.2.5.3.1.2. For vehicles having an exhaust provided with outlets spaced more than 0.3 m apart or more than one silencer, one set of measurement is made for each outlet."

Paragraph 3.2.5.3.1.3. amend to read:

"3.2.5.3.1.3. If a vehicle has two or more exhaust outlets spaced less than or equal to 0.3 m apart and connected to a single silencer, only one set of measurement shall be made. The microphone shall be located relative to the outlet furthest away from the vehicle longitudinal centreline, or when such outlet does not exist, to the outlet, which is highest above the ground."

Paragraph 3.2.5.3.1.5. amend to read:

"3.2.5.3.1.5. For vehicles, where the reference point of the exhaust pipe is not accessible, or located under the vehicle body, as shown in Figure 3b and 3c in Annex 3, because of the presence of obstacles which form part of the vehicle (e.g. spare wheel, fuel tank, battery compartment), the microphone shall be located at least 0.2 m from the nearest obstacle, including the vehicle body, and shall not be located under the vehicle. Its axis of maximum sensitivity shall face the exhaust outlet from the position least concealed by the above-mentioned obstacles. In case the distance from the exhaust outlet to the other side of the vehicle is larger than 0.2 m (Figures 3c and 3d in Annex 3), the following distances of d_1 and d_2 shall be chosen:

Case 1:

d_1 shall be equal to 0.5 m and the distance from the side (outer border of the vehicle) shall be at least 0.2 m.

d_2 shall be equal to 0.5 m and the distance from the side (outer border of the vehicle) shall be at least 0.2 m.

Case 2 (if Case 1 is not fulfilled):

d_1 shall be at least 0.5 m and the distance from the side (outer border of the vehicle) shall be equal to 0.2 m.

d_2 shall be at least 0.5 m and the distance from the side (outer border of the vehicle) shall be equal to 0.2 m.

When several positions are possible, as shown in Figure 3c, the microphone position giving the lowest value of d_1 or d_2 shall be used."

Paragraph 3.2.5.3.2.1., amend to read:

"3.2.5.3.2.1. Target engine speed

The target engine speed is defined as:

- (a) 75 per cent of the rated engine speed S for vehicles with a rated engine speed $\leq 5,000 \text{ min}^{-1}$;
- (b) $3,750 \text{ min}^{-1}$ for vehicles with a rated engine speed above $5,000 \text{ min}^{-1}$ and below $7,500 \text{ min}^{-1}$;
- (c) 50 per cent of the rated engine speed S for vehicles with a rated engine speed $\geq 7,500 \text{ min}^{-1}$.

If the vehicle cannot reach the engine speed as stated above, the target engine speed shall be 5 per cent below the maximum possible engine speed for that stationary test.

For vehicles for which the engine speed is a fixed value, (for example, but not limited to, series hybrids) either above or below the target engine speed and

cannot be adjusted by the accelerator, the test shall be carried out at the fixed engine speed.

In case the engine speed deviates from the applicable target engine speed, the engine speed used for the test and the reason for the deviation shall be documented in the test report and at paragraph 2.2. of Appendix 1 to Annex 1."

Paragraph 3.2.6., amend to read:

"3.2.6. Results for sound emitted by stationary vehicles

3.2.6.1. Single test position (outlet)

For the vehicles equipped with one exhaust outlet or two or more exhaust outlets as specified in paragraph 3.2.5.3.1.3., the stationary sound of the vehicle shall be determined for one test position.

At least three measurements for a test position (outlet) shall be made.

The maximum A-weighted sound pressure level indicated during each of the three measurements shall be recorded to the first decimal place.

The first three valid consecutive measurement results, within 2 dB(A), allowing for the deletion of non-valid results (see paragraph 2.1. except the specifications of the test site), shall be used for the determination of the final result for the given measurement position.

The result for a test position (outlet) is the arithmetic average of the three valid measurements, mathematically rounded to the nearest integer value (e.g. 72.5 shall be noted as to 73 while 72.4 shall be noted as to 72).

3.2.6.2. Multiple test positions (outlets)

For vehicles equipped with multiple exhaust outlets as specified in paragraph 3.2.5.3.1.2., the stationary sound of the vehicle shall be determined for each test position, following the measurement and calculation principles above.

The reported sound pressure level shall be for the test position having the highest average sound pressure level.

3.2.6.3. Modes

If the vehicle has different modes according to the definition 2.25.1. the stationary sound of the vehicle shall be determined for each mode, following the measurement and calculation principles above.

The sound pressure level for each mode shall be reported according to 3.2.6.1. in case the vehicle has only a single test position (outlet) and according to 3.2.6.2. in case of multiple test positions (outlets).

3.2.7. Stationary sound pressure level representative for the vehicle type²

If the vehicle has only one mode and a single test position (outlet), the representative sound pressure level for the vehicle type is determined by the measurement result according to paragraph 3.2.6.1.

If the vehicle has only one mode but multiple test positions (outlets), the representative sound pressure level for the vehicle type is determined by the measurement result according to paragraph 3.2.6.2.

If the vehicle has multiple modes and one or more test positions (outlets), the representative sound pressure level for the vehicle type is determined by the measurement result according to paragraph 3.2.6.3. In the test report and paragraph 2.2. of Appendix 1 to Annex 1 the representative test result determined by the principles above and the name of the mode shall be

² See Figure 6 of Annex 3, Appendix

documented for every mode. The representative sound pressure level for the vehicle type and its registration papers is the highest reported sound pressure level of all modes as documented in paragraph 2.2. of Appendix 1 to Annex 1."

Annex 3

Appendix, amend to read:

"Figure 3a

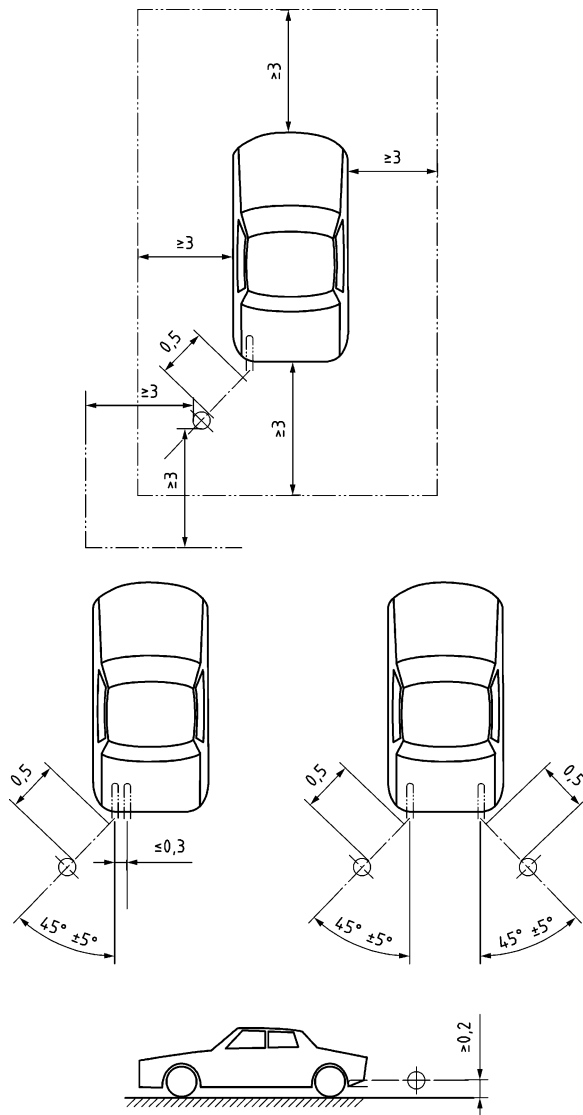

Figure 3b

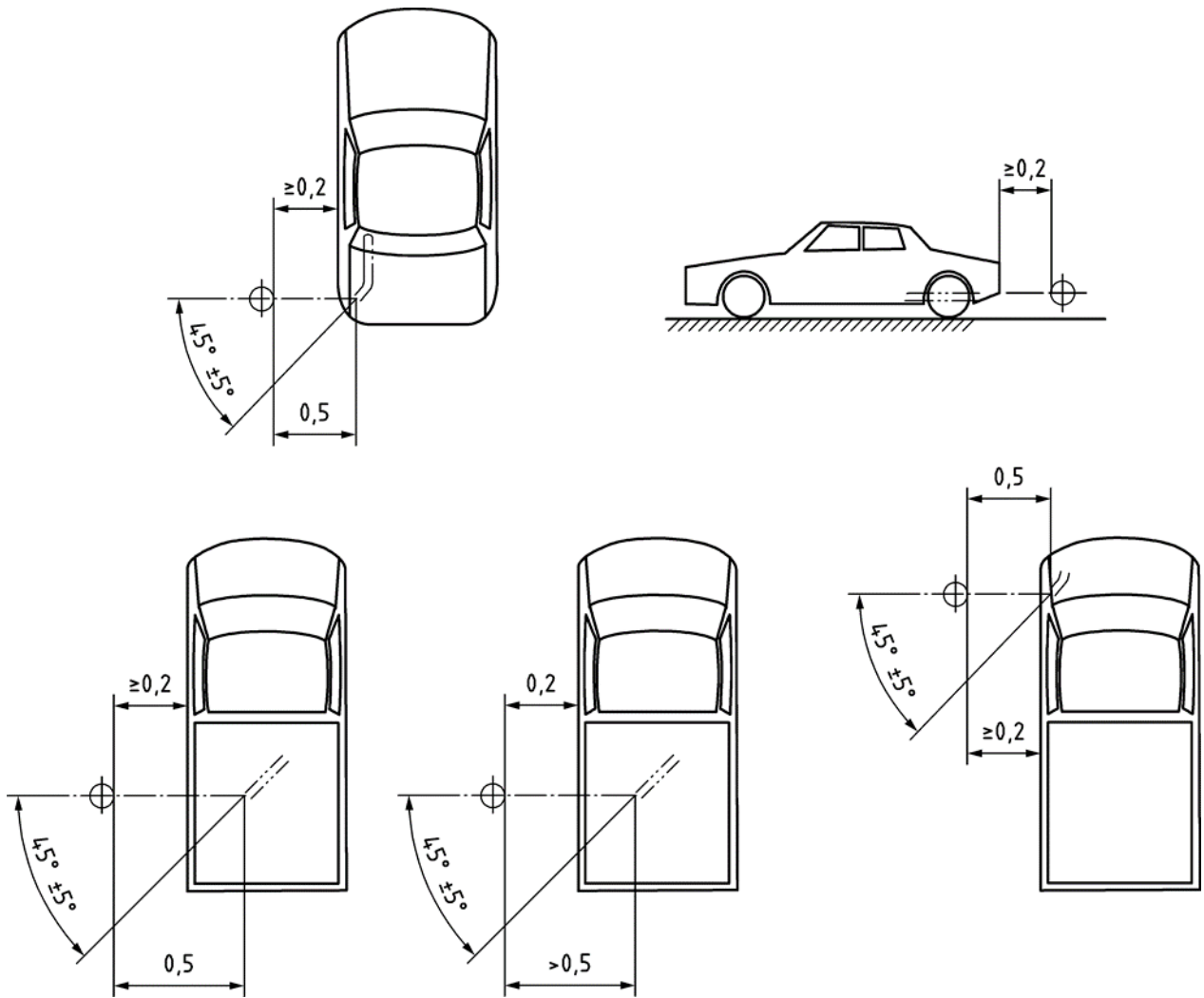

Figure 3c

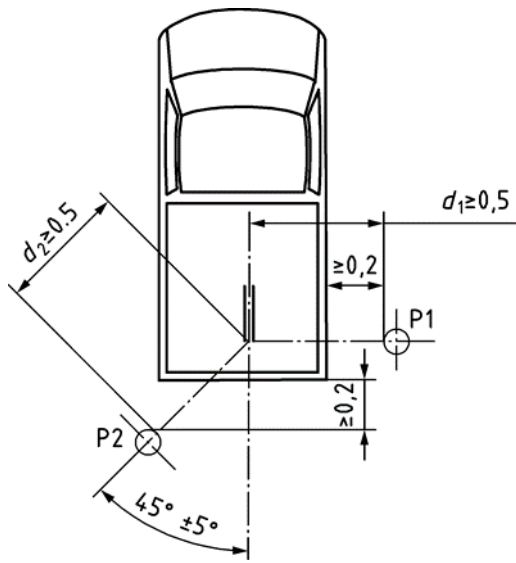

Figure 3d

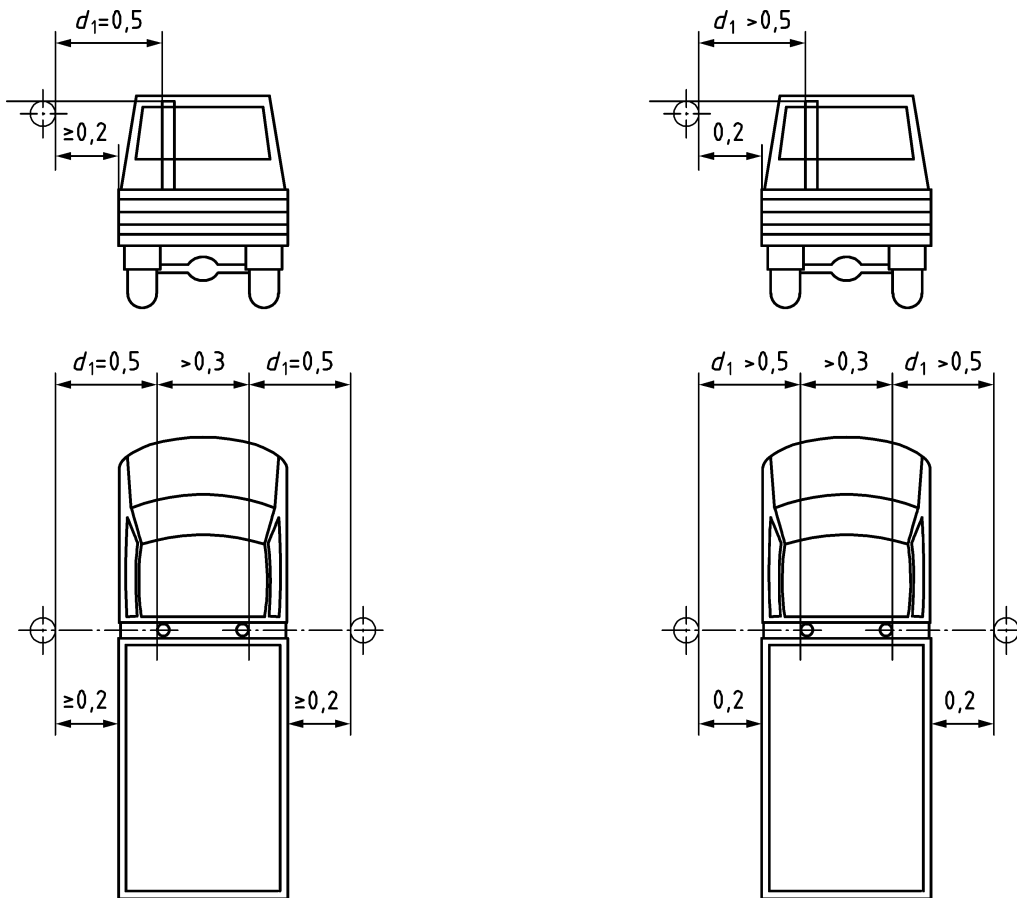
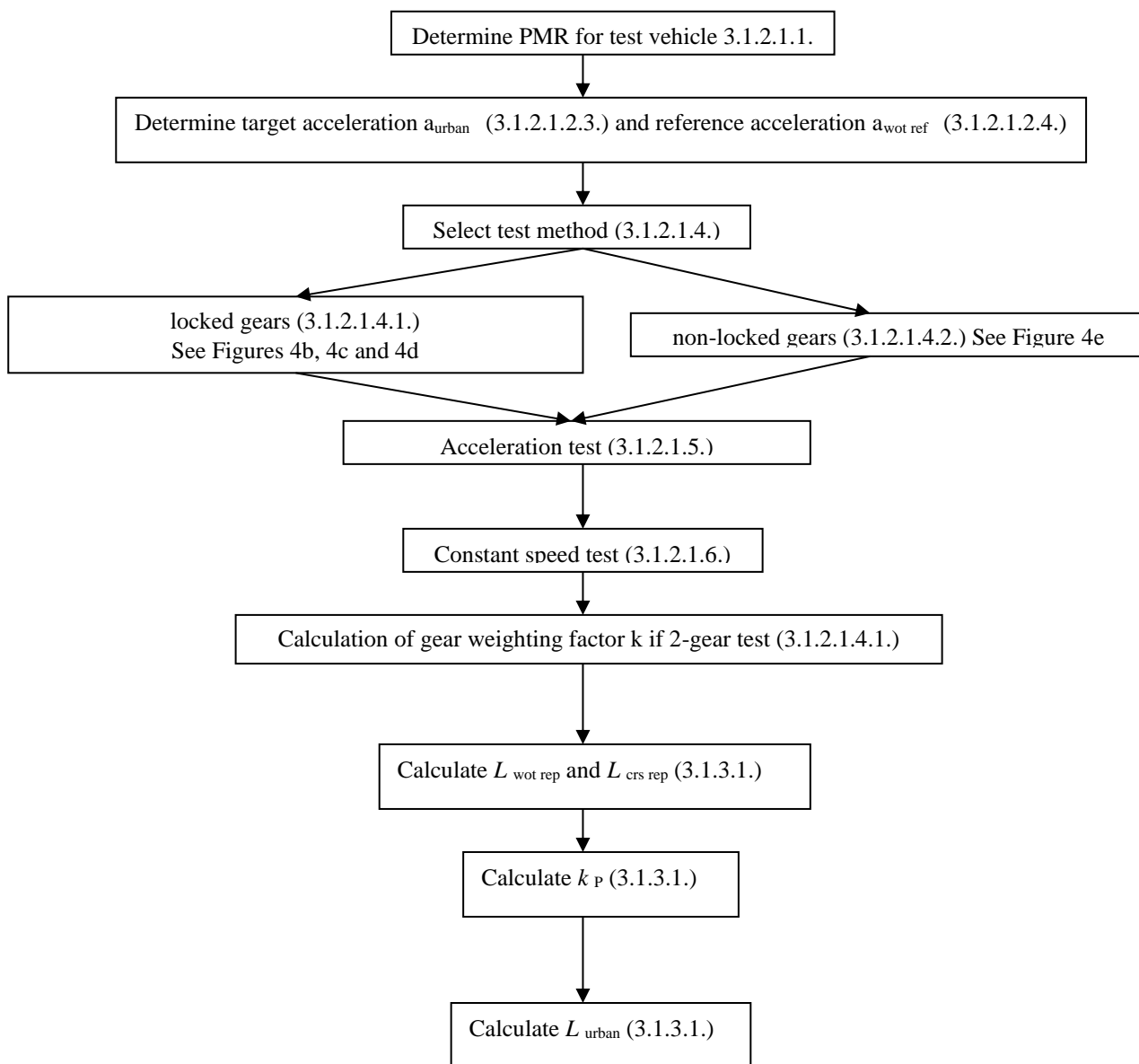

Figure 4a, amend to read:

Figure 4a

Flowchart for vehicles tested according to paragraph 3.1.2.1. of Annex 3 to this Regulation
– L_{urban} computation



”

Figure 4b, amend to read:

"Figure 4b

Flowchart for vehicles tested according to paragraph 3.1.2.1. of Annex 3 to this Regulation
- Gear selection using locked gear.

PART 1

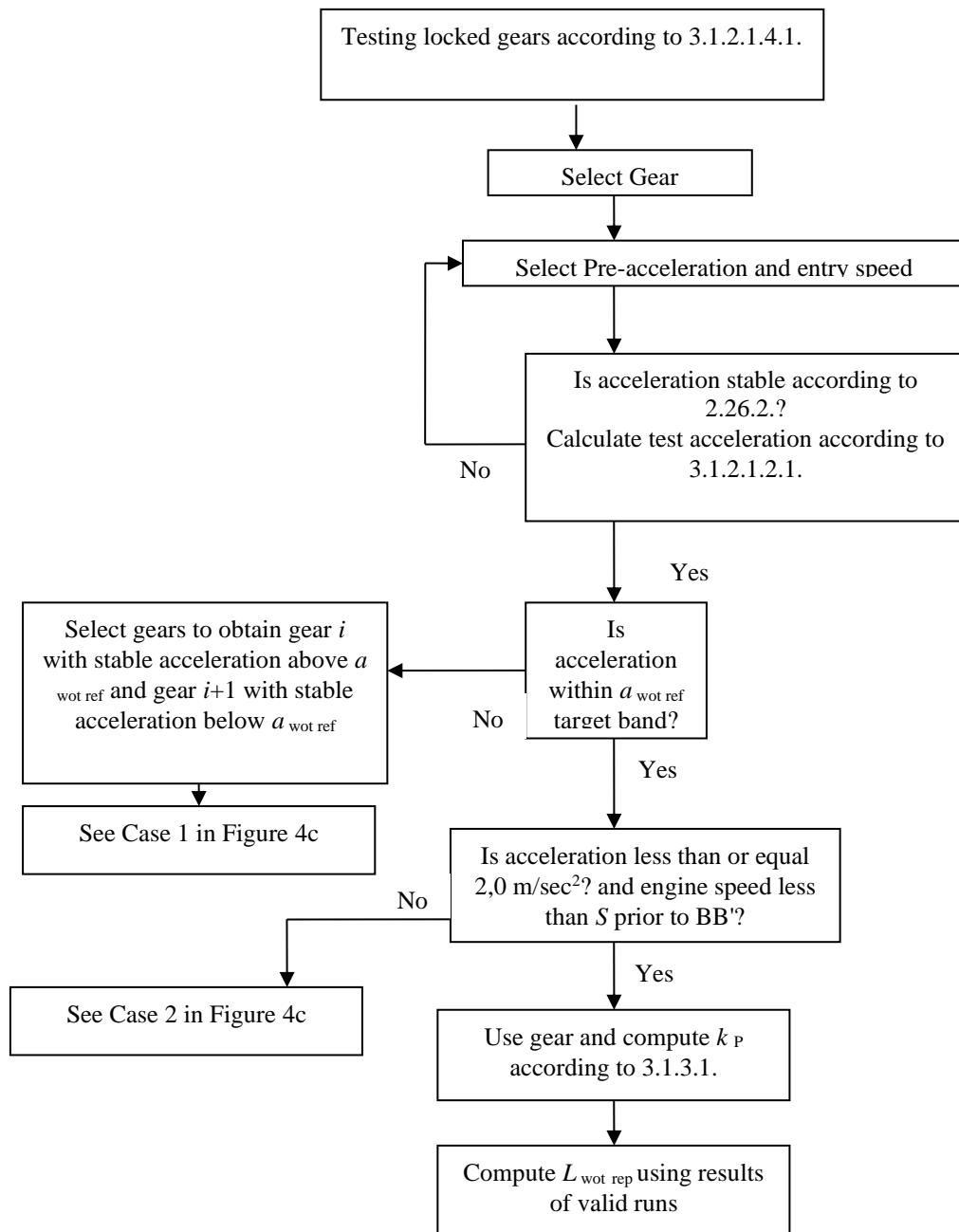

"

Add a new Figure 6:

"Figure 6
Flowchart for measurement and data processing of stationary sound according to paragraph 3.2.

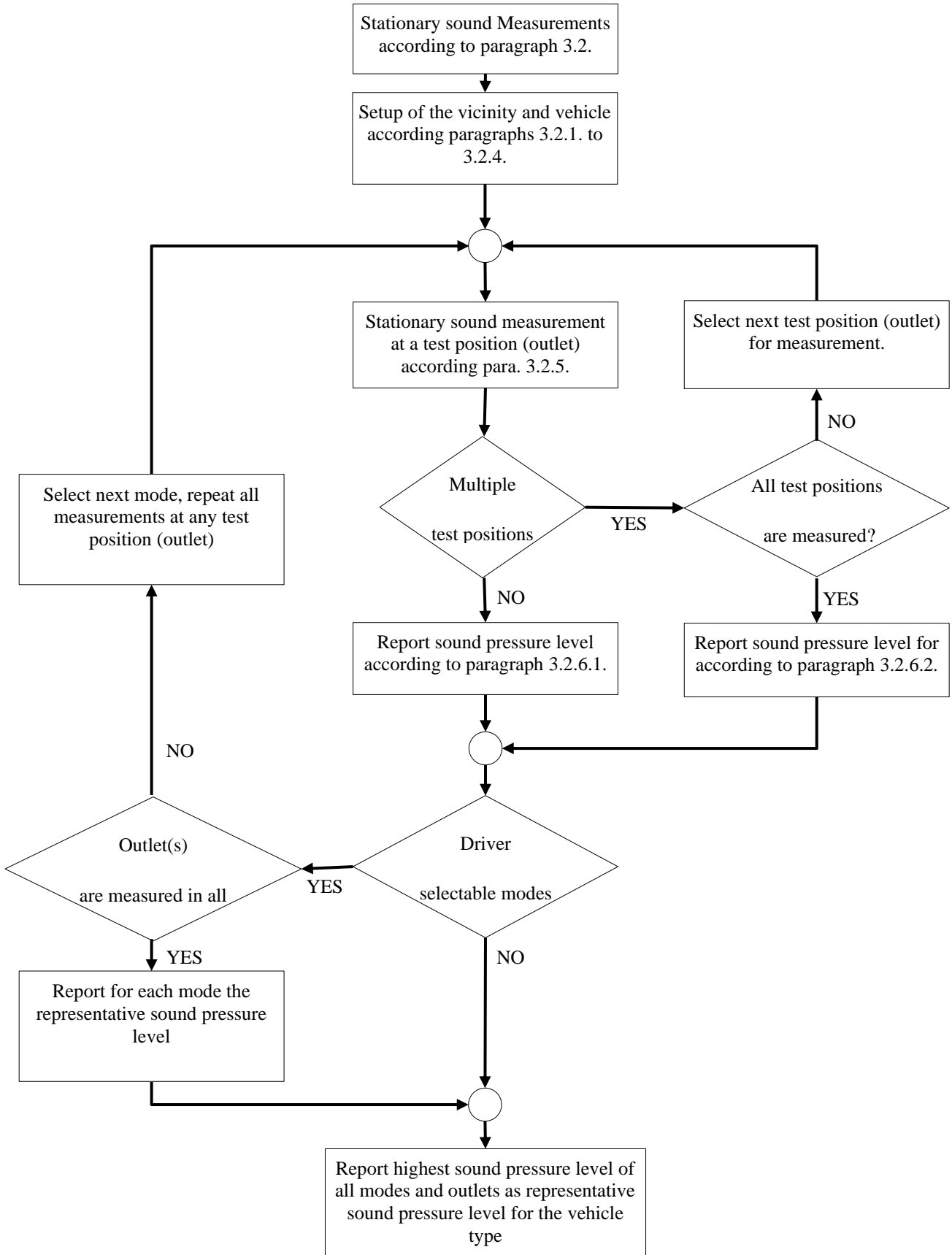

Annex 6

Paragraph 2.1., amend to read:

"2.1. The vehicle(s) under test shall be subjected to the test for measurement of sound of vehicle in motion as described in paragraph 3.1. of Annex 3.

For vehicles of category M₁, N₁ and M₂ ≤ 3,500 kg technically permissible maximum laden mass,

- The same mode, gear(s)/gear ratio(s), gear weighting factor k and partial power factor k_P as determined during the type approval process may be used, provided this information are available from the type approval test report for the applicable vehicle variant of the family. If not, this information shall be determined anew. The test report shall document which way of data processing was selected;
- The test mass m_t of the vehicle shall be between 0.90 m_{ro} ≤ m_t ≤ 1.20 m_{ro}."

Annex 7

Paragraph 2.4., amend to read:

"2.4. Target conditions

The sound emission shall be measured in each valid gear ratio at the four test points as specified below. For all test points the boundary conditions as specified in paragraph 2.3. shall be met.

The gear ratio is valid if all four points and the anchor point meet the specifications of paragraph 2.3. above. Any gear ratio for which this criteria is not fulfilled is invalid and not analysed further.

The first test point P1 is defined by using an entry speed v_{AA,k1} of 20 km/h ≤ v_{AA,k1} < 20 km/h + 3 km/h.

For P1, if a stable acceleration condition according to the definition of 2.26.1 cannot be achieved, the speed v_{AA,k1} shall be increased in steps of 5 km/h until a stable acceleration is reached.

For all points, stable acceleration according to the definition of 2.26.3. shall be verified by comparing the acceleration a_{wot_test,AA-BB} calculated between line AA' and line BB' with the acceleration a_{wot_test,PP-BB} calculated between line PP' and BB'.

If the ratio a_{wot_test,PP-BB} / a_{wot_test,AA-BB} does not exceed or is equal to 1,20, then proceed with the acceleration calculation between line AA' and Line BB'.

If the ratio a_{wot_test,PP-BB} / a_{wot_test,AA-BB} does exceed 1,20, then proceed with the acceleration calculation between line PP' and line BB'.

In case of non-locked transmission conditions where n_{BB_ASEP} is exceeded during the test, the following measures shall be considered separately or together:

- Provisions of paragraph 2.5.1.
- Increased speed in steps of 5 km/h.

The test speed for the fourth test point P4 in any gear is defined by either

- 0.95 x n_{BB_ASEP} ≤ n_{BB,k4} ≤ n_{BB_ASEP}; or
- v_{BB_ASEP} - 3 km/h ≤ V_{BB,k4} ≤ V_{BB_ASEP} with V_{BB_ASEP} as defined in paragraph 2.3.

The test speed for the other two test points is defined by the following formula:

Test Point P_j: $v_{BB,kj} = v_{BB,k1} + ((j - 1) / 3) * (v_{BB,k4} - v_{BB,k1})$ for $j = 2$ and 3 with a tolerance of ± 3 km/h

Where:

$v_{BB,k1}$ = vehicle speed at BB' of test point P₁

$v_{BB,k4}$ = vehicle speed at BB' of test point P₄."

Paragraph 2.5.1., amend to read:

"2.5.1. The path of the centreline of the vehicle shall follow line CC' as closely as possible throughout the entire test, starting from the approach of the reference point according to definition 2.11. of the main body to line AA' until the rear of the vehicle passes line BB'.

At line AA' the accelerator shall be fully depressed. To achieve a more stable acceleration according definition 2.26.2. or to avoid a downshift between line AA' and BB', pre-acceleration before line AA' may be used according to the provisions of paragraphs 3.1.2.1.2.1. and 3.1.2.1.2.2. of Annex 3. The accelerator shall be kept in depressed condition until the rear of the vehicle reaches line BB'.

In case of non-locked transmission conditions, the test may include a gear ratio change to a lower range and a higher acceleration. A gear change to a higher range and a lower acceleration is not allowed.

If possible, the manufacturer shall take measures to avoid that a gearshift leads to a condition not in compliance with the boundary conditions. For that, it is permitted to establish and use electronic or mechanical devices, such as alternate gear selector positions. If no such measures can be applied, the rationale shall be provided and documented in the technical report.

Table 1 in Appendix to Annex 3 provides examples for valid measures to control the downshift of gears. Any measure used by manufacturer for the above-mentioned purposes shall be documented in the test report."

Paragraph 2.5.2., amend to read:

"2.5.2. Measurements reading:

Per test point, one single run is carried out.

For every separate test run, the following parameters shall be determined and noted:

The maximum A-weighted sound pressure level of both sides of the vehicle, indicated during each passage of the vehicle according to paragraph 3.1.2.1.5. of Annex 3, shall be mathematically rounded to the first decimal place ($L_{wot,kj}$). If a sound peak obviously out of character with the general sound pressure level is observed, the measurement shall be discarded. Left and right side may be measured simultaneously or separately. For further processing, the higher sound pressure level of both sides shall be used."
