

## TRANS-EUROPEAN NORTH-SOUTH MOTORWAY (TEM)

# TEM STANDARDS AND RECOMMENDED PRACTICE

**Third Edition**

February 2002



**TEM Project Central Office**

10 Gołędzinowska St.  
03 302 Warsaw  
POLAND



# TABLE OF CONTENTS

	<b>INTRODUCTION</b>	1
<b>1</b>	<b>GENERAL CONSIDERATIONS</b>	2
1.1	<b>General Characteristics – Scope</b>	2
1.2	<b>Stages of Construction</b>	2
1.2.1	Scope	2
1.2.2	Alternative Stage Solutions	3
<b>2</b>	<b>PLANNING</b>	7
2.1	<b>Level of Service</b>	7
2.1.1	Scope	7
2.1.2	Selection of Level of Service	7
2.2	<b>Traffic Factors to be Considered</b>	7
2.2.1	Scope	7
2.2.2	Motorway Characteristics Determined by Traffic Forecasts and Level of Service	8
<b>3</b>	<b>DESIGN PARAMETERS</b>	13
3.1	<b>Parameters of Alignment</b>	13
3.1.1	Design Speed Definition – Horizontal and Vertical Alignment	13
3.1.2	Design Speed	13
3.1.3	Design Speed at Interchanges and Tunnels	14
3.1.4	Horizontal Curves	14
3.1.5	Transition Curves	14
3.1.6	Vertical Curves	15
3.1.7	Gradients	15
3.1.8	Crossfall	16
3.1.9	Sight Distance	16
3.2	<b>Cross Section</b>	17
3.2.1	Scope	17
3.2.2	Carriageways	17
3.2.3	Central Reserve	21
3.2.4	Shoulders	21
3.2.5	Overhead Clearance	22

<b>3.3</b>	<b>Interchanges</b>	22
3.3.1	Scope	22
3.3.2	Types of Interchanges	23
3.3.3	Location	23
3.3.4	Characteristics of Slip Roads	25
3.3.5	Weaving Sections	25
3.3.6	Divergence of Traffic Flows	26
3.3.7	Convergence of Traffic Flows	26
<b>3.4</b>	<b>Additional Lanes</b>	27
3.4.1	Scope	27
3.4.2	Acceleration Lanes	27
3.4.3	Deceleration Lanes	28
3.4.4	Other Additional Lanes	28
<b>3.5</b>	<b>Pavements</b>	29
3.5.1	Scope	29
3.5.2	Factors Influencing Structural Design	29
3.5.3	Design Methods	31
<b>3.6</b>	<b>Slipperiness and Evenness</b>	31
3.6.1	Scope	31
3.6.2	Geometric Characteristics	31
3.6.3	Slipperiness	33
3.6.4	Evenness	33
<b>3.7</b>	<b>Drainage Systems for Surface and Subsoil Water</b>	33
3.7.1	Scope	33
3.7.2	Parameters for System Design	33
3.7.3	Systems of Drainage for Surface Water	34
3.7.4	Systems of Drainage for Subsoil Water	37
3.7.5	Water Catchment and Pollution Prevention Measures and Facilities	41
<b>3.8</b>	<b>Connections to TEM</b>	42
3.8.1	General Concept	42
3.8.2	Design Specifications for TEM Connections	43
3.8.3	Traffic Signs and Equipment	44
3.8.4	Environment	44
<b>4</b>	<b>TRAFFIC REGULATION AND SAFETY FACILITIES</b>	45
<b>4.1</b>	<b>General Characteristics</b>	45
4.1.1	Scope	45
4.1.2	Harmonisation	45
4.1.3	Location	45
4.1.4	Colour	46
4.1.5	Reflectorisation	46

<b>4.2</b>	<b>Motorway Markings</b>	46
4.2.1	General Requirements	46
4.2.2	Special Requirements	47
<b>4.3</b>	<b>Motorway Signs</b>	49
4.3.1	Scope	49
4.3.2	General Requirements	50
4.3.3	Particular Cases	53
4.3.4	Illuminated Signs	56
<b>4.4</b>	<b>Marker Posts</b>	61
4.4.1	Scope	61
4.4.2	Sizes	61
4.4.3	Colour	61
4.4.4	Material	61
4.4.5	Location	62
4.4.6	Reflective or Equivalent Devices	62
4.4.7	Spacing	62
<b>4.5</b>	<b>Miscellaneous Safety Devices</b>	62
4.5.1	Scope	62
4.5.2	Safety Barriers	62
<b>4.6</b>	<b>Emergency Call System</b>	65
4.6.1	General Requirements	65
4.6.2	Call Posts	65
4.6.3	Operation Centre	66
<b>4.7</b>	<b>Antiglare Devices</b>	67
<b>4.8</b>	<b>Precautions Concerning Animals</b>	67
4.8.1	Scope	67
4.8.2	Measures for Protection from Animals	68
4.8.3	Overpasses and Underpasses for Wild Animals	68
<b>4.9</b>	<b>Traffic Control and Provisions for Traffic Diversion</b>	68
4.9.1	General	68
4.9.2	Information for Users	69
4.9.3	Information for Management Agencies	70
4.9.4	Regulatory Measures in Congested Situations, during Roadworks or after Accidents	70
4.9.5	General Monitoring of Traffic Data	71
4.9.6	Installation of Portable Emergency Traffic Signs	72
<b>4.10</b>	<b>Light Signals and Motorway Lighting</b>	73
4.10.1	Scope	73
4.10.2	Light Signals	73
4.10.3	Road Lighting	73

<b>5</b>	<b>FACILITIES</b>	75
<b>5.1</b>	<b>Types</b>	75
<b>5.2</b>	<b>Rest Areas</b>	75
<b>5.3</b>	<b>Service Areas</b>	75
<b>5.4</b>	<b>Spacing Criteria of Rest and Service Areas</b>	76
5.4.1	Distance from Interchanges	76
5.4.2	Distance between Rest Areas	76
5.4.3	Distance between Service Areas	76
<b>5.5</b>	<b>Location of Rest and Service Areas</b>	77
5.5.1	Topography of Terrain	77
5.5.2	Horizontal and Vertical Alignment of Motorway	77
5.5.3	Degree of Urbanisation at Sites	77
5.5.4	Scenic and Historic Values	77
<b>5.6</b>	<b>Design Criteria of Rest and Service Areas</b>	78
5.6.1	General	78
5.6.2	Capacity of Facilities	78
5.6.3	Acceleration and Deceleration Lanes	78
5.6.4	Internal Circulation and Distribution of Sites Equipped for Parking	78
5.6.5	Electrical Systems	79
5.6.6	Road Markings and Signs and Safety	80
5.6.7	Water Supply and Sanitary Systems	80
5.6.8	Landscaping	80
5.6.9	Pedestrian Crossings	81
<b>5.7</b>	<b>Buildings and Equipment</b>	81
5.7.1	Promotional Centres	81
5.7.2	Sanitary Facilities	81
<b>5.8</b>	<b>Toll Facilities</b>	82
5.8.1	Scope	82
5.8.2	General Criteria	83
<b>5.9</b>	<b>Frontier Check-Points</b>	85
5.9.1	General	85
5.9.2	Types of Frontier Check-Points	85
5.9.3	Technical and Operational Requirements for the Location of Frontier Check-Points	86
5.9.4	Buildings and Installations in the Area of the Frontier Check-Point	87

<b>6</b>	<b>ENVIRONMENTAL CONSIDERATIONS</b>	<b>88</b>
<b>6.1</b>	<b>Scope</b>	<b>88</b>
<b>6.2</b>	<b>Environmental Impact Assessment</b>	<b>88</b>
6.2.1	Strategic Environmental Impact Assessment (SEIA)	88
6.2.2	Environmental Impact Assessment (EIA)	88
<b>6.3</b>	<b>Insertion into the Surrounding Environment</b>	<b>89</b>
6.3.1	Aesthetics and Landscape	89
6.3.2	Infrastructures and Ecology	91
<b>6.4</b>	<b>Anti-Noise Measures</b>	<b>91</b>
6.4.1	Guidelines Relating to Design Stage	91
6.4.2	Guidelines Relating to Construction Stage	92
6.4.3	Guidelines Relating to Operation Stage	92
<b>6.5</b>	<b>Anti-Pollution Measures</b>	<b>92</b>
6.5.1	Air Pollution	92
6.5.2	Pollution of Watercourses and Water Table	92
6.5.3	Protection of Fauna and Flora	93
<b>6.6</b>	<b>Anti-Vibration Measures</b>	<b>93</b>
6.6.1	Guidelines Relating to Design Stage	93
6.6.2	Guidelines Relating to Construction Stage	93
6.6.3	Guidelines Relating to Operation Stage	93
<b>6.7</b>	<b>Protection of Slopes and Planting of Central Reserve</b>	<b>94</b>
6.7.1	Protection of Slopes on Embankments and in Cuts	94
6.7.2	Landscaping on Central Reserve	95
<b>6.8</b>	<b>Public Information, Consultation and Participation</b>	<b>96</b>
<b>6.9</b>	<b>Monitoring</b>	<b>97</b>
<b>7</b>	<b>BRIDGES</b>	<b>98</b>
<b>7.1</b>	<b>Scope</b>	<b>98</b>
<b>7.2</b>	<b>Types of Structures</b>	<b>98</b>
<b>7.3</b>	<b>Hydrologic and Hydraulic Considerations</b>	<b>98</b>
7.3.1	General	98
7.3.2	Data	99
<b>7.4</b>	<b>Bridge Design Actions</b>	<b>99</b>
<b>7.5</b>	<b>Design General</b>	<b>100</b>

<b>7.6</b>	<b>Detailed Requirements</b>	100
<b>7.7</b>	<b>Safety Measures on Bridges</b>	101
7.7.1	Scope	101
7.7.2	Restraint Systems on Bridges	101
7.7.3	Safety Barriers in Approach Zones	101
7.7.4	Pedestrian Parapets	101
7.7.5	Restraint Systems on Motorway Bridges	101
7.7.6	Rainwater Disposal Systems	102
7.7.7	Cleaning and Maintenance of Rainwater Disposal Systems	102
<b>7.8</b>	<b>Access to Critical Zones of Bridges and Viaducts</b>	103
<b>8</b>	<b>TUNNELS</b>	104
<b>8.1</b>	<b>Scope</b>	104
8.1.1	General	104
8.1.2	Advantages of Motorway Alignments with Tunnels	104
8.1.3	Geological and Geotechnical Studies	105
8.1.4	Decisions Regarding Suitability of Techniques of Tunnel Construction	105
<b>8.2</b>	<b>Guidelines Related to Technical Characteristics</b>	106
8.2.1	General	106
8.2.2	Capacity and Service Levels	106
8.2.3	Determination of Tunnel Characteristics	106
<b>8.3</b>	<b>Traffic Regulation</b>	108
8.3.1	General	108
8.3.2	Traffic Regulation to Avoid Lowering the Service Level	109
8.3.3	Traffic Regulation in Emergency Situations	109
8.3.4	Traffic Regulation Regarding Heavy Vehicles and Transport of Dangerous Goods	109
8.3.5	Signing of Tunnel Approaches	109
<b>8.4</b>	<b>Equipment</b>	110
8.4.1	General	110
8.4.2	Installation	110
<b>8.5</b>	<b>Ventilation</b>	111
8.5.1	General	111
8.5.2	Natural Ventilation	111
8.5.3	Artificial Ventilation	111
8.5.4	Pollution in the Area of Tunnel Portals	113
8.5.5	Recirculation between Portals	113
8.5.6	Monitoring	113



<b>8.6</b>	<b>Lighting</b>	113
8.6.1	General	113
8.6.2	Lighting Sections	114
8.6.3	Lengths of Sections	114
8.6.4	Daytime Luminance Levels	114
8.6.5	Nighttime Luminance Levels	115
8.6.6	Emergency Lighting	115
8.6.7	Choice of Lighting System	115
8.6.8	Power Supply and Control Devices	115
8.6.9	Special Cases	116
<b>9</b>	<b>MAINTENANCE RELATED TO DESIGN</b>	117
<b>9.1</b>	<b>General Considerations</b>	117
<b>9.2</b>	<b>Engineering Structures</b>	117
<b>9.3</b>	<b>Pavements</b>	117
<b>9.4</b>	<b>Embankments, Cuts and Walls</b>	118
<b>9.5</b>	<b>Auxiliary Works</b>	118
<b>9.6</b>	<b>Buildings</b>	119
<b>9.7</b>	<b>Maintenance Centres</b>	119
9.7.1	General	119
9.7.2	Functional Organization of the Maintenance Centre	119



## INTRODUCTION

These standards were elaborated under technical guidance provided by the countries participating in the Trans-European North-South Motorway Project (TEM) and were adopted by the Steering Committee of the Project.

They are based on the original TEM Standards of January 1981 and on their first revision of July 1992. This second revision was accomplished by the working group made up of the representatives of most of the TEM countries. In the course of this revision, inter alia the Consolidated text of the European Agreement on Main International Traffic Arteries (AGR) as revised by Amendments 1 to 7, 1997 update of the Highway Capacity Manual (US Transportation Research Board Special Report 209) and the present state of European standardisation (CEN/TC's 226 and 227) were taken into account.

The role of these standards is to ensure that the planning and design of the TEM motorway provide for the adequate traffic flow at minimum operating cost, while ensuring harmonized conditions for motorway users, proper level of service, safety, speed and driver comfort over medium and long distances.

Specific provisions were formulated in accordance with the following subdivision:

- a) Essential and uniform throughout the whole length of the TEM. Countries would make every effort within reason to comply with these standards as a minimum: (S);
- b) Recommended practice: (RP);
- c) Although their primary application will be to the Trans-European North-South Motorway, these standards are at disposal to other United Nations countries which find them beneficial for the formulation or updating of their national standards.

# **1 GENERAL CONSIDERATIONS**

## **1.1 General Characteristics – Scope**

1.1.1 The TEM is classified as „motorway”.

1.1.2 These standards, therefore, refer to a highway which (S):

- 1) is specially designed and built for motor traffic and does not serve properties bordering on it;
- 2) is provided, except at special points or temporarily, with separate carriageways for the two directions of traffic, separated from each other by a dividing strip (central reserve) not intended for traffic or, exceptionally, by other means;
- 3) does not cross at level with any road, railway or tramway track, or footpath;
- 4) is specially sign-posted as a motorway.

1.1.3 In addition to that, the TEM shall:

- (a) be provided with hard shoulders of adequate width, on which no other than emergency stopping is allowed (see paragraph 3.2.4) (S);
- (b) have a sufficient distance between the interchanges (see paragraph 3.3.3) (RP);
- (c) be provided with its own police and maintenance services (RP).

## **1.2 Stages of Construction**

### **1.2.1 Scope**

1.2.1.1 In relation to the forecast traffic demand, each section of the TEM should at all times in its design lifetime function within the pre-established level of service <sup>(1)</sup> (cf. Chapter 2) (RP).

---

(1) “Level of service” is a term which, broadly interpreted, denotes any one of an infinite number of differing combinations of operating conditions that may occur on a given lane or roadway when it is accommodating various traffic volumes. Level of service is a qualitative measure of the effect of a number of factors, which include inter alia speed and travel time, traffic interruptions, freedom to manoeuvre, safety, driving comfort and convenience, and operating costs. In practice, selected specific levels are defined in terms of particular limiting values of certain of these factors.

- 1.2.1.2 This can be achieved basically in two ways:
- (a) by immediately constructing the motorway with the general characteristics as defined in Section 1.1 and with a capacity <sup>(1)</sup> such as to guarantee the pre-established level of service (RP). In this case each carriageway - being one-way - will have, among other characteristics, a minimum of two traffic lanes;
  - (b) by providing for an initial construction stage and for subsequent expansion stages in line with the expected growth in traffic demand, in such a way that the level of service offered to the user never falls below the pre-established level. The initial construction stage should guarantee the pre-established level of service for the traffic volumes forecast in the first 10 years of motorway operations.
- 1.2.1.3 Sections built in accordance with paragraph 1.2.1.2 (a) must be designed in conformity with these standards and must at all times correspond to the definition of the TEM as given in Section 1.1 (S).
- 1.2.1.4 Sections built in accordance with paragraph 1.2.1.2 (b) above are considered as provisional, and hence may not always and completely correspond to the TEM definition as given in Section 1.1.
- 1.2.2 Alternative Stage Solutions**
- 1.2.2.1 Construction in successive stages (phased construction) should be carried out in such a way that each stage is in harmony with the subsequent one, thereby reducing to a minimum any adjustment works (RP).
- 1.2.2.2 Additions and widening carried out in the presence of traffic should not be scheduled too closely together in time, so as to avoid too frequent lowering of the levels of service offered to users (RP).
- 1.2.2.3 In phased construction, various situations may arise in relation to the average level of service intended for the different phases, such as:

---

(1) "Capacity" is the maximum number of vehicles which have a reasonable expectation of passing over a given section of a lane or a roadway in one direction (or in both directions for a two-lane or a three-lane highway) during a given time period under prevailing roadway and traffic conditions. In the absence of time modifier, capacity is an hourly volume. The capacity would not normally be exceeded without changing one or more of the conditions that prevail. In expressing capacity, it is essential to state the prevailing roadway and traffic conditions under which the capacity is applicable.

- (a) initial stage with a single two-way carriageway (1x2) and with complete control of access. The central reserve, second carriageway and possible additional lanes for each of the two definitive carriageways would be constructed in subsequent stages;
- (b) initial stage with two one-way carriageways with two lanes each (2x2), with a central reserve and full control of access. Possible additional lanes and/or other elements of the motorway would be constructed in subsequent stages.

1.2.2.4 In the initial construction stage, the section shall have certain characteristics which are considered as important and proper to the definition itself:

- (a) full control of access (S);
- (b) hard shoulders or, in exceptional cases, lay-bys spaced at appropriate intervals (S);
- (c) climbing lanes in cases where the conditions described in Chapter 2 occur (S);
- (d) complete side fencing of the motorway (RP);
- (e) horizontal and vertical motorway-type road signs and markings (S);
- (f) service facilities provided in proportion to the volume of traffic (RP);
- (g) suitable services to guarantee maintenance of the motorway, its structures and facilities (S).
- (h) crossfall corresponding to the future full profile of the motorway (S).

1.2.2.5 It should be noted that complete control of access can be maintained by means of the following:

- (a) grade separation with interchanges;
- (b) grade separation without interchanges;
- (c) deviation of intersecting roads.

1.2.2.6 Alternatives of phased construction other than those mentioned under paragraph 1.2.2.3 are possible, such as an initial stage with only two-way (1x2) carriageway with some or all level crossings, or with one-way carriageways with two lanes each (2x2) with some or all level crossings; these, however, are not recommended.

1.2.2.7 Of the alternatives introduced under paragraphs 1.2.2.3 and 1.2.2.6, only the solution with 2x2 or more lanes and full control of access will be classed and posted as a TEM motorway section, whereas the others will be posted as TEM route connecting sections.

- 1.2.2.8 Initial Stage with Single Two-Way Carriageway
  - 1.2.2.8.1 In the initial stage with a single two-way carriageway, the traffic lane should consist of two 3.75 m wide lanes (on rough terrain and when the design speed is 80 km/h, the traffic lane width may be reduced from 3.75 m to 3.50 m), flanked by shoulders at least 3.00 m wide each, of which at least 2.50 m would be paved or stabilized to permit emergency stops (cf. Figures 3a, 3b, 3c) (RP).
  - 1.2.2.8.2 The same cross-section should be maintained on structures exceeding 100 m in length, except for the shoulder, which may be reduced to 2.25 m in width (RP).
- 1.2.2.9 Initial Stage with Two One-Way Carriageways
  - 1.2.2.9.1 In the initial stage with two one-way carriageways, the running section must have the dimensional characteristics shown in Figures 3a, 3b, 3c (S).
  - 1.2.2.9.2 Reduced cross section could be applied for the design speed of 80 km/h for possible use in difficult terrain.
  - 1.2.2.9.3 This reduced cross section would show a minimum width of the central reserve of 3.00 m where no hard obstacles are present, and 3.50 m where isolated hard obstacles occur on the central reserve.
- 1.2.2.10 TEM Standard Stage
  - 1.2.2.10.1 In this stage, all conditions as introduced in Section 1.1 must be satisfied on TEM motorway proper. With regard to connections to TEM, see Section 3.8.
  - 1.2.2.10.2 The widening criteria should in all cases guarantee a capacity in conformity with the high service levels and homogeneity required, especially in terms of safety, on all sections of the motorway (RP).
  - 1.2.2.10.3 Control of Access

The transformation of at-grade crossings constructed in the initial stage into grade-separated interchanges to obtain complete control of access should take place gradually in time and space so as to avoid disturbance to traffic and taking account of specific local conditions (RP).

- 1.2.2.10.4      Cross Section
- On sections where the initial construction stage consists of a single two-way carriageway (1x2), the subsequent stage would entail the doubling of the cross section of the preceding stage (cf. Figures 3a, 3b, 3c), taking into account the following standards:
- (a) on embankments and in cuts, one of the two shoulders should constitute part of the central reserve (RP);
  - (b) in the presence of bridges, a second structure of similar cross section should be constructed (S);
  - (c) in the presence of single-bore tunnels, the second bore must be constructed at a distance from the first such that the construction does not constitute a danger to traffic (S).
- 1.2.2.11      Subsequent Stages
- 1.2.2.11.1      Wherever the traffic demand so requires, the capacity may be increased by the construction of a third lane, at least 3.50 m wide (cf. Figures 3a, 3b, 3c), which should be built to the outside of each carriageway (RP).
- 1.2.2.11.2      The shoulder dimensions would remain the same as indicated in the preceding stage (RP).
- 1.2.2.11.3      On bridges, the shoulder may be used as the third lane except where there is a strong possibility that the subsequent stage will be built within ten years of the TEM standard stage (RP).
- 1.2.2.11.4      Where it is possible to utilize immediately lands destined for other purposes (e.g. farming), the widening may be made towards the inside; this will entail a greater width of the central reserve in the preceding stage, with all the related consequences (e.g., water disposal, etc.).
- 1.2.2.11.5      Whenever the traffic demand so requires, the service volume may be increased by addition, on the outside, of further lanes. In such a case, these additional lanes must be at least 3.50 m in width (S).
- 1.2.2.11.6      This latter solution is not advisable, however, except in the vicinity of urban areas where the presence of local traffic could lead medium- and long-distance users to tolerate flow conditions interrupted by a succession of entry and exit slip roads to and from closely spaced interchanges.
- 1.2.2.11.7      Also in this case, however, it would be preferable to adopt solutions which would provide for the physical separation of local traffic from transit traffic (RP).



## **2 PLANNING**

### **2.1 Level of Service**

#### **2.1.1 Scope**

The determination of the cross-section elements, especially the number and width of lanes, must be performed in relation to the level of service which is intended for the user (S).

#### **2.1.2 Selection of Level of Service**

2.1.2.1 The basic traffic quantities to be considered in determining the level of service are the volumes at the 50<sup>th</sup> peak hour, expressed in PCU (passenger car units) (RP). A PCU corresponds to a private car; for other vehicles a PCU equivalent shall be applied (cf. Tables 2c and 2d).

2.1.2.2 The 50<sup>th</sup> peak hour value may be expressed in terms of the Annual Average Daily Traffic (AADT) <sup>(1)</sup> as follows (RP):

$T_{50}^{th} h = 0.14 \text{ AADT}$  in cases of two divided one-way carriageways;  $T_{50}^{th} h = 0.12 \text{ AADT}$  <sup>(2)</sup> in cases of single two-way carriageways.

2.1.2.3 A minimum level of service C should be guaranteed (RP).

### **2.2 Traffic Factors to be Considered**

#### **2.2.1 Scope**

2.2.1.1 With regard to the levels of service, the elements of the cross section should in general be derived from the limits reported in Section 2.1 (RP).

2.2.1.2 The traffic to consider should be, in the first stage, the volume foreseeable for 15<sup>th</sup> operating year as a minimum (RP).

2.2.1.3 The following paragraphs set out the standards and values to be adopted on embankments and in cuts.

Traffic in tunnels and on bridges will be dealt with in the later chapters dealing with these.

---

(1) "Average Annual Daily Traffic" (AADT) is the total yearly traffic volume divided by the number of days in the year.

(2) Total figure for both directions of travel.

**2.2.2 Motorway Characteristics Determined by Traffic Forecasts and Level of Service**

2.2.2.1 Number of Lanes

The number of lanes necessary should be determined in accordance with Tables 2a (motorway with two one-way carriageways) and 2b (single two-way carriageway), taken from 1997 update of HCM (RP).

2.2.2.2 The figures for service volumes shown on the tables are to be considered as valid under good weather conditions and in daylight. In regions where weather conditions are normally poor or in those where nighttime traffic amounts to at least 1/3 or more of the daytime traffic, with high percentages of freight vehicles, it would be advisable to reduce the capacities for average service levels by up to 40% and the corresponding possible speeds by up to 15% (RP).

2.2.2.3 In cases where one two-way carriageway is sufficient in the first stage, it will be necessary to control access as indicated in paragraphs 1.2.2.3 and 1.2.2.4 (S).

2.2.2.4 It will sometimes be convenient to adopt a wider – and hence more costly – cross section, when the following conditions are likely to occur:

- (a) speed distributions with very high standard deviations;
- (b) distribution of traffic among a large number of vehicle classes with different dynamic and encumbrance characteristics;
- (c) high concentration of motorway access points.

2.2.2.5 Lateral Clearance

2.2.2.5.1 Lateral obstacles can result in vehicle slowdown for psychological reasons, and thus bring about a reduction in the level of service.

2.2.2.5.2 This phenomenon can be overcome by leaving at least 3.00 m of the shoulder free of any obstacles. Where safety fences are necessary, these should be located outside the shoulders (RP).

2.2.2.6 A marginal strip should be maintained along the edge of the innermost lane; this can be limited to at least 50 cm as long as the obstacle in question is represented by the safety fence installed along the central reserve (RP).

2.2.2.7 In this case, in fact, the obstacle represents a continuous element especially designed and installed for safety reasons, and hence there is no longer the element of surprise which constitutes the essential factor conditioning vehicle progress.

Table 2a – Source HCM 1997

<b>LEVELS OF SERVICE CRITERIA FOR BASIC MOTORWAY SECTIONS</b>				
<b>LEVEL OF SERVICE</b>	<b>MAXIMUM DENSITY (pc/km/ln)</b>	<b>MINIMUM SPEED (km/h)</b>	<b>MAXIMUM SERVICE FLOW RATE (pc/h/ln)</b>	<b>MAXIMUM v/c RATIO</b>
FREE-FLOW SPEED = 120 km/h				
A	6	120	720	0.29
B	10	120	1,200	0.47
C	15	115	1,725	0.68
D	20	104	2,080	0.85
E	28	85.7	2,400	1.00
F	>28	<85.7	>2,400	>1.00
FREE-FLOW SPEED = 110 km/h				
A	6	110	660	0.28
B	10	110	1,100	0.44
C	15	109	1,635	0.66
D	20	101	2,020	0.84
E	28	84.0	2,350	1.00
F	>28	<84.0	>2,350	>1.00
FREE-FLOW SPEED = 100 km/h				
A	6	100	600	0.26
B	10	100	1,000	0.42
C	15	100	1,500	0.63
D	20	96	1,920	0.81
E	28	82.0	2,300	1.00
F	>28	<82.0	>2,300	>1.00
FREE-FLOW SPEED = 90 km/h				
A	6	90	540	0.24
B	10	90	900	0.39
C	15	90	1,350	0.59
D	20	90	1,800	0.78
E	28	80.4	2,250	1.00
F	>28	<80.4	>2,250	>1.00

Table 2b – Source HCM 1997

**LEVELS OF SERVICE FOR SINGLE TWO-LANE HIGHWAY  
(INITIAL MOTORWAY CONSTRUCTION STAGE) SEGMENTS**

Level of Service	% Time Delay	v/c RATIO (1)																				
		LEVEL TERRAIN							ROLLING TERRAIN							MOUNTAINOUS TERRAIN						
		AVG SPD <sup>(2)</sup> km/h	PERCENT NO PASSING ZONES						AVG SPD <sup>(2)</sup> km/h	PERCENT NO PASSING ZONES						AVG SPD <sup>(2)</sup> km/h	PERCENT NO PASSING ZONES					
			0	20	40	60	80	100		0	20	40	60	80	100		0	20	40	60	80	100
A	30	93	0.15	0.12	0.09	0.07	0.05	0.04	92	0.15	0.10	0.07	0.05	0.04	0.03	90	0.14	0.09	0.07	0.04	0.02	0.01
B	45	88	0.27	0.24	0.21	0.19	0.17	0.16	87	0.26	0.23	0.19	0.17	0.15	0.13	87	0.25	0.20	0.16	0.13	0.12	0.10
C	60	83	0.43	0.39	0.36	0.34	0.33	0.32	82	0.42	0.39	0.35	0.32	0.30	0.28	79	0.39	0.33	0.28	0.23	0.20	0.16
D	75	80	0.64	0.62	0.60	0.59	0.58	0.57	79	0.62	0.57	0.52	0.48	0.46	0.43	72	0.58	0.50	0.45	0.40	0.37	0.33
E	>75	72	1.00	1.00	1.00	1.00	1.00	1.00	64	0.97	0.94	0.92	0.91	0.90	0.90	56	0.91	0.87	0.84	0.82	0.80	0.78
F	100	<72	-	-	-	-	-	-	<64	-	-	-	-	-	-	<56	-	-	-	-	-	-

- (1) Ratio of flow rate to an ideal capacity of 2800 pc/h in both directions.
- (2) These speeds are provided for information only and apply to roads with design speeds of 100km/h or higher.

- 2.2.2.8 Gradients and Climbing Lanes
  - 2.2.2.8.1 To calculate the influence of heavy vehicles, adjustment factors have to be applied to service volumes.
  - 2.2.2.8.2 For the motorway, the following passenger car equivalents should be used:

Table 2c – Source HCM 1997

Average Generalized Passenger Car Equivalents on Motorways

Vehicle type	Type of terrain		
	Level	Rolling	Mountainous
trucks and buses, $E_H$	1.5	3.0	6.0

along with the formula (RP):

$$T = \frac{1}{1 + P_T (E_H - 1)}$$

where:

- $T$  is the heavy-vehicle adjustment factor;
- $P_T$  is the proportion of trucks or buses in the traffic stream, expressed as a decimal;
- $E_H$  is the passenger car equivalent for truck and buses.

2.2.2.8.3 For two-lane highway (initial motorway construction stage), the following passenger car equivalents should be used:

Table 2d – Source HCM 1997

Average Generalized Passenger Car Equivalents for Trucks and Buses on Two-lane Highways, over General Terrain Segments

VEHICLE TYPE	LEVEL OF SERVICE	TYPE OF TERRAIN		
		LEVEL	ROLLING	MOUNTAINOUS
Trucks, $E_T$	A	2.0	4.0	7.0
	B and C	2.2	5.0	10.0
	D and E	2.0	5.0	12.0
Buses, $E_B$	A	1.8	3.0	5.7
	B and C	2.0	3.4	6.0
	D and E	1.6	2.9	6.5

along with the formula (RP):

$$T = \frac{1}{1 = P_T (E_T - 1) + P_B (E_B - 1)}$$

where:

$T$  is the heavy-vehicle adjustment factor;

$P_T$  is the proportion of trucks in the traffic stream, expressed as a decimal;

$P_B$  is the proportion of buses in the traffic stream, expressed as a decimal;

$E_T$  is the passenger car equivalent for truck;

$E_B$  is the passenger car equivalent for buses.

2.2.2.9 In order to maintain a service level for cars on climbing sections equivalent to that on the flat, additional (climbing) lanes are to be constructed (S).

## **3 DESIGN PARAMETERS**

### **3.1 Parameters of Alignment**

#### **3.1.1 Design Speed Definition – Horizontal and Vertical Alignment**

3.1.1.1 The design speed is the speed which determines the layout of a new road, both in plan and in cross section, being the maximum safe speed for which the road is designed (S).

3.1.1.2 Possible design and construction in successive stages will have no influence upon the selection of the final design speed, but may influence the determination of the most restrictive geometric characteristics adopted in the first stage.

3.1.1.3 The motorway should have similar geometric characteristics over sufficiently long sections (RP).

3.1.1.4 Possible variations in the geometric characteristics should occur only at points acceptable to the user (for example, in passing from urban to extra-urban zones, or where the morphology of the terrain crossed undergoes change) (RP).

3.1.1.5 If this is not possible, the variation in the geometric characteristics should occur gradually (RP).

3.1.1.6 Horizontal and vertical alignment should be such that the user notices no unjustified breaks in continuity, and is given timely warning of the critical points along the route, especially in the vicinity of interchanges, so that he can execute the necessary manoeuvres (RP).

3.1.1.7 In order to achieve a smooth alignment, it is suggested to observe the following recommendations (RP):

- (a) avoid the use of very long straights;
- (b) try to maintain conformity, where possible, between the horizontal and vertical alignments;
- (c) insert, between two horizontal circular curves, connecting curves of variable radius (transition curves).

#### **3.1.2 Design Speed**

3.1.2.1 In general, the design speed along the whole length of the TEM is 120 km/h (S).

3.1.2.2 It is, however, possible to adopt a lower design speed on particular sections with difficult topography. Design speeds of 100 km/h or even 80 km/h will thus be acceptable where justified by economic and technical considerations (RP).

3.1.2.3 Where environmental features permit, it is also possible to adopt a design speed of 140 km/h (RP).

**3.1.3 Design Speed at Interchanges and Tunnels**

3.1.3.1 No reduction at all in the design speed of the motorway should be allowed at interchanges and tunnels (RP).

3.1.3.2 Only in cases where this might be justifiable by technical and economic reasons, will it be possible to adopt lower design speed within tunnels. A reduction of no more than 25% would be accepted, and in no case may the speed drop below 80 km/h (S).

**3.1.4 Horizontal Curves**

3.1.4.1 The minimum radii for horizontal curves for each design speed are shown in Table 3a.

3.1.4.2 Table 3a gives minimum radii at 7% crossfall (see paragraph 3.1.8) related to design speed:

Table 3a

Design Speed (km/h):	140	120	100	80
Minimum Horizontal Radii (m):	1000	650	450	240

**3.1.5 Transition Curves**

3.1.5.1 For the length (L) of the transition curves on the motorway proper, the greater of the values obtained with the following criteria should be adopted (RP):

$$(a) \quad L \geq \frac{v^3}{RC} \left( 1 - \frac{Rg\delta}{v^2} \right)$$

where:

v = design speed (m/sec)

g = acceleration of gravity (m/sec<sup>2</sup>)

R = radius of the curve to be connected (m)

δ = superelevation (1)

C = variation of the centrifugal acceleration in time units, no greater than 0.5 m/sec<sup>3</sup>;

---

(1) "Superelevation" is the transverse inclination given to the cross section of a carriageway throughout the length of a horizontal curve to reduce the effects of centrifugal force on a moving vehicle.



(b)  $L \geq \frac{\Delta h}{0.005}$  where  $\Delta h$  = the difference in elevation of edges compared to axis (m).

3.1.5.2 This means that the average value of the relative gradient of the edges of the carriageway with respect to the axis of the motorway ought not exceed 0.5%. Moreover, the rotation zone should be dimensioned so as to minimize the possibility of aquaplaning phenomena.

**3.1.6 Vertical Curves**

3.1.6.1 The minimum radii of convex vertical curves are given in the following table for each design speed (RP):

Table 3b

Design Speed (km/h):		140	120	100	80
Minimum Radii for Convex Vertical Curves (m):	2 - Way Carriageway:	-	-	10,000	4,500
	1 - Way Carriageway:	27,000	12,000	6,000	3,000

3.1.6.2 The figures regarding the concave curves should be calculated for each design speed in such a way as to entail a vertical acceleration of no more than 0,25 m/sec<sup>2</sup> (RP).

3.1.6.3 The values referring to the two-way carriageway have to be used in those cases where the motorway in the first stage consists only of a single two-way carriageway (S).

**3.1.7 Gradients**

3.1.7.1 Table 3c gives for each design speed the maximum gradients necessary to ensure that passenger vehicles maintain the related design speed:

Table 3c

Design Speed (km/h)	140	120	100	80
Maximum Gradient	3%	4%	5%	6%

3.1.7.2 The length of the section with gradient higher than 3% should be limited in proportion to the gradient value (RP).

3.1.7.3 For drainage reasons, the gradient should never be less than 0,3% (RP).

**3.1.8 Crossfall**

3.1.8.1 Normal crossfall must be sufficient to facilitate the disposal of rainwater and not be less than 2% (S).

3.1.8.2 Normal crossfalls should be maintained on curves with radii greater than or equal to those shown in the following table (RP):

Table 3d

Design Speed (km/h)	140	120	100	80
Radius (m)	4,500	3,500	2,500	2,000

3.1.8.3 On curves having radii less than the figures shown in the above table, crossfall should be determined in accordance with the design speed and the transversal friction coefficient, up to a maximum value of 7% corresponding to the minimum radius (RP).

**3.1.9 Sight Distance**

3.1.9.1 A sight distance at least equivalent to the stopping distance has to be maintained along the whole length of the motorway (S).

3.1.9.2 In calculating the sight distance, account must be taken of the gradient of the motorway (S).

3.1.9.3 On curves, the stopping distance should be increased by 25% in the case of radii of a value of less than 5 V metres, where V is the design speed expressed in km/h.

3.1.9.4 Minimum stopping distances for level and straight conditions are given in the following table (RP):

Table 3e

Design Speed (km/h)	140	120	100	80
Stopping Distance (m)	325	200	150	100

3.1.9.5 In case of construction by successive stages (i.e., an initial single two-way carriageway), the minimum sight distances necessary for overtaking are given in the following table for each design speed (S):

Table 3f

Design Speed (km/h)	140	120	100	80
Absolute Minimum Sight Distance for Overtaking (m)	-	-	400	325
Desirable Minimum Sight Distance for Overtaking (m)	-	-	600	475

3.1.9.6 These distances should be guaranteed along the route of the motorway in high percentages and distributed uniformly (RP).

3.1.9.7 On portions of the route where these distances are not guaranteed, road markings and signs banning overtaking must be posted (S).

## **3.2 Cross Section**

### **3.2.1 Scope**

3.2.1.1 The cross section of the motorway should allow maintenance of the design service level throughout the design life, and over every section of the route (cf. Chapter 2).

3.2.1.2 The cross section has to comprise two one-way carriageways, separated by a median or central reserve of suitable dimensions (S).

3.2.1.3 Each carriageway should consist of a number of lanes in proportion to the traffic volumes forecast, but in no case fewer than two (S).

3.2.1.4 Along the whole length of the motorway a shoulder of suitable size should be provided; part of the shoulder should be paved so as to accommodate emergency stops. Where specific technical or economic considerations make it necessary to omit the emergency stopping lane, lay-bys must be provided at suitable intervals (S).

3.2.1.5 In tunnels, the cross section dimensions should comply with paragraph 8.2.3.2.

3.2.1.6 Climbing lanes must be provided wherever the conditions described in Chapter 2 occur (S).

3.2.1.7 Figures 3a, 3b, 3c show the minimum cross sections on embankments and in cuts, on bridges and in tunnels.

### **3.2.2 Carriageways**

3.2.2.1 In case of two one-way carriageways, traffic lanes should have a width of 3.75 m (RP).

3.2.2.2 In exceptional cases or where further lanes are provided, the lane width could be reduced to 3.50 m (RP).

3.2.2.3 Edge markings must not be calculated as part of the width of the lanes (S).

SINGLE TWO-LANE CARRIAGEWAY (1x2)

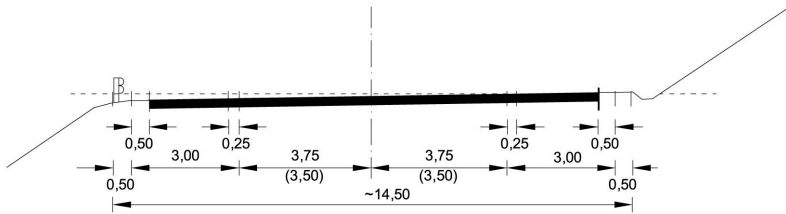

DUAL TWO-LANE CARRIAGEWAY (2x2)

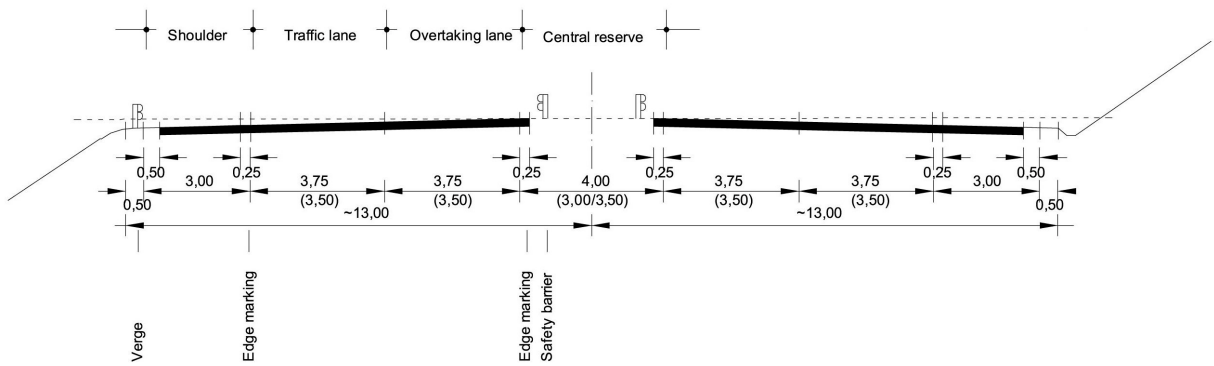

DUAL THREE-LANE CARRIAGEWAY (2x3)

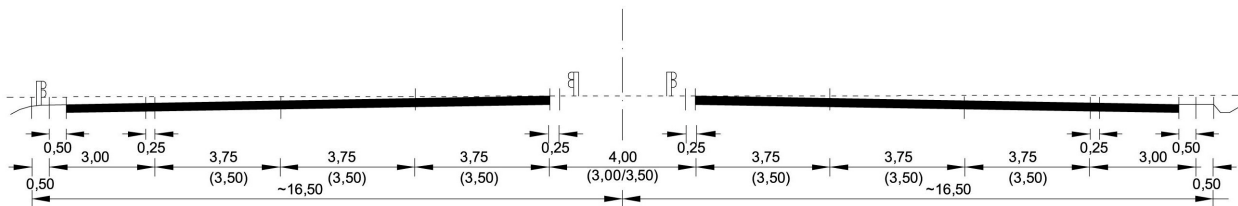
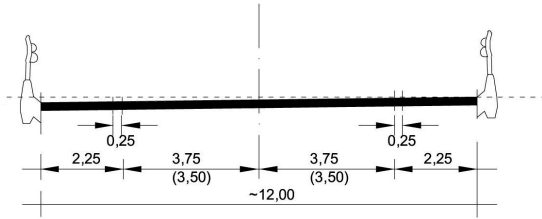
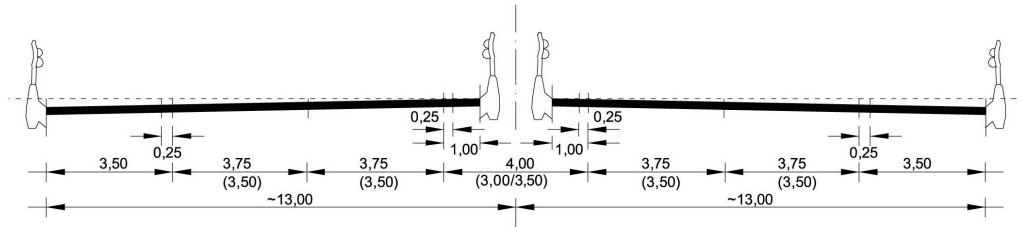

Fig. 3a - Cross section on cuts and embankments

SINGLE TWO-LANE CARRIAGEWAY (1x2)



DUAL TWO-LANE CARRIAGEWAY (2x2)



DUAL THREE-LANE CARRIAGEWAY (2x3)

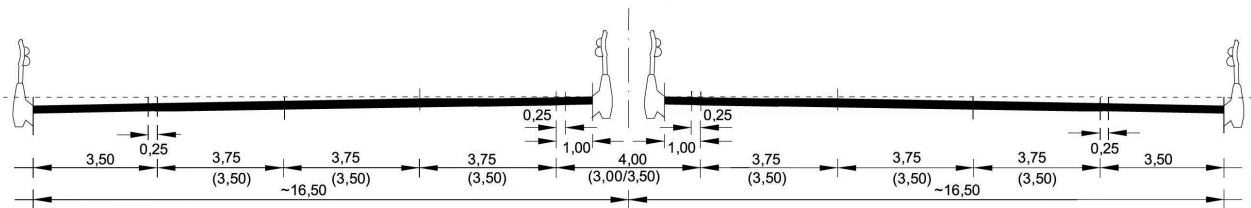
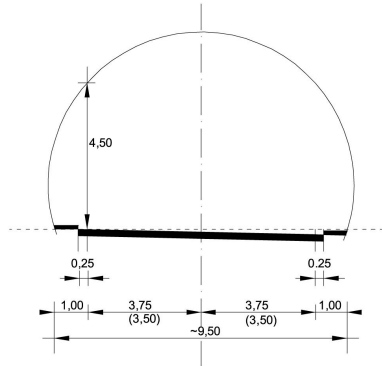
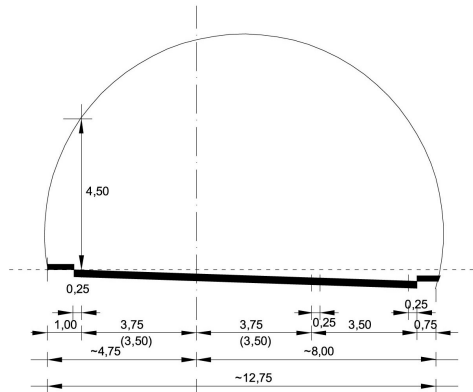

Fig. 3b - Cross section on bridges

OR SEPARATE ONE-WAY TWO-LANE CARRIAGEWAY (1X2)  
WITHOUT SHOULDER



SEPARATE ONE-WAY TWO-LANE CARRIAGEWAY (1X2)  
WITH SHOULDER



SEPARATE ONE-WAY THREE-LANE CARRIAGEWAY (1X3)  
WITHOUT SHOULDER

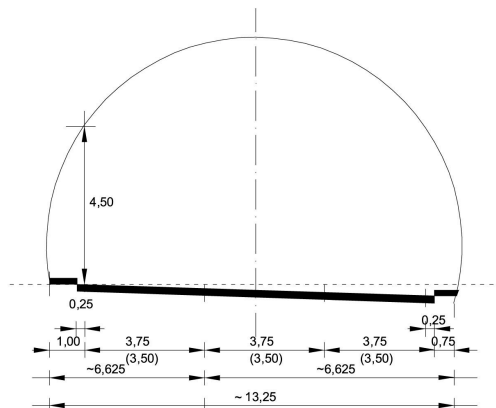

Fig. 3c - Cross section in tunnels

3.2.2.4 In cases of temporary construction of only one carriageway, this must have, on straights, a cross section with a minimum crossfall of 2% in one direction (S).

### **3.2.3 Central Reserve**

3.2.3.1 Wherever possible, central reserve should have a width of no less than 4.00 m for section of motorway with design speeds of 140 km/h, 120 km/h and 100km/h, and no less than 3.00 m for sections of motorway with a design speed of 80 km/h – these widths including the edge lines of 0.25 m each. Changes in the width of the central reserve should be made gradually (RP).

3.2.3.2 The provision of a safety barrier on the central reserve depends on traffic volumes and central reserve widths (see also paragraphs 4.5.2 and 4.5.2.7).

3.2.3.3 Where construction is undertaken in stages (a single two-way carriageway), one of the two shoulders should occupy part of the central reserve of the cross section of the subsequent stage (two one-way carriageways)(RP).

3.2.3.4 The continuity of the permanent safety barrier should be interrupted at central reserve crossovers to permit closing of a carriageway and the utilization of the other as a two-way carriageway while maintenance work is performed on the closed one, as well as to permit service and assistance vehicles to effect “U” turns so as to intervene more quickly in emergencies (RP).

### **3.2.4 Shoulders**

3.2.4.1 The width of the shoulders should be equal to at least 3.00 m, of which 2.50 m is paved, so as to permit emergency stops. It would, however, be advisable to adopt shoulder widths up to 3.75 m (RP).

3.2.4.2 In cases where it is impossible to provide an emergency lane, but only lay-bys, the width of the shoulder should be no less than 0.50 m (RP).

3.2.4.3 An edge marking – guideline – 0.25 m in width should be provided between the shoulder and the carriageway (RP).

3.2.4.4 On the outside of the shoulder there should also be provided a verge of 0.50 m in width, where a safety fence shall be installed if required (cf. Chapter 4) (RP).

3.2.4.5 The crossfall of paved shoulders must be at least equal to that of the carriageway (S).

3.2.4.6 The crossfall of the unpaved part of the shoulder should be 8%, oriented towards the outside (RP).

### 3.2.5 Overhead Clearance

Overhead clearance has to be equivalent to at least 4.50 m plus 0.20 m to permit eventual repaving (S).

## 3.3 Interchanges

### 3.3.1 Scope

3.3.1.1 Interchanges are grade-separated intersections with interconnecting carriageways.

3.3.1.2 Interchanges consist of principal carriageways and slip roads.

3.3.1.3 Principal carriageways are those which carry the largest volumes of traffic and for which no significant reduction in design speed shall be tolerated; these should always be one-way carriageways.

3.3.1.4 Slip roads may be partially two-way roads, but their entries and exits to and from the motorway should always be one way.

3.3.1.5 Slip roads should be considered and hence designed as independent road elements; different types of slip roads can be assembled to produce many forms of interchange.

3.3.1.6 It is very important that the choice of interchange layout to be used be made in the light of the following objectives:

- (a) simplicity;
- (b) uniformity;
- (c) regularity;
- (d) economy.

3.3.1.6.1 Uniformity here means “operative” uniformity, i.e. connected with the fact that motorway users expect to have to undertake “similar” manoeuvres even on “different” types of interchange.

3.3.1.7 The form of the interchange will be influenced by the topography of the terrain, by the volume and composition of the traffic, and by the type of intersecting road involved.

3.3.1.8 A further factor determining the choice of interchange layout may be the possible presence of toll collection points.



3.3.1.8.1 For both technical and economic reasons, it is preferable in this case to provide for a single toll station. The construction of a number of such stations would entail greater construction costs as well as higher operation and maintenance costs. It is obvious that this constraint limits the choice of the form of interchange in such cases.

3.3.1.9 If an interchange is located on the motorway section to be constructed in successive stages, account must be taken from the beginning of the dimensions envisaged for the final stages, so as to reduce to a minimum any expenditure on carriageways and structures, etc., which will have to be borne in the later stages.

### **3.3.2 Types of Interchanges**

3.3.2.1 Interchanges between the motorway and other roads may be of two types:

- A: Interchanges between the motorway and roads of the same category;
- B: Interchanges between the motorway and all-purpose roads.

3.3.2.2 Figure 3d shows examples of interchange types which could be adopted depending on the importance of the intersecting road.

### **3.3.3 Location**

3.3.3.1 Places where interchanges with other international roads, motorways and other roads are necessary, are to be determined in the feasibility and location studies (S). In deciding on the location of an interchange on the motorway, the following factors should be taken into account:

- (a) trip length (travel distance);
- (b) size of the urban areas;
- (c) predicted traffic volumes;
- (d) cost of interchange construction;
- (e) congestion control;
- (f) possibilities of advance signing (see Figures 4a and 4b).

3.3.3.2 The distance between two successive interchanges is an element of great importance in ensuring the desired level of service.

3.3.3.3 In suburban zones, therefore, where high traffic demand might require the construction of more frequent interchanges, it is necessary to establish a minimum distance between successive interchanges depending on the weaving traffic (see paragraph 3.3.3.5).

TYPE OF INTERSECTING FACILITY	RURAL	(SUB) URBAN
ALL PURPOSE ROAD Category I		
ALL PURPOSE ROAD Category II		
MOTORWAY OR EXPRESS ROAD		

Fig. 3d - Examples of interchanges (in absence of toll)

### 3.3.4 Characteristics of Slip Roads

3.3.4.1 The cross section of slip roads should have the following dimensions (cf. Figure 3e):

- (a) one-way carriageway: width of minimum 6.00 m including edge marking and shoulders (RP);
- (b) two-way carriageway: width of minimum 9.00 m including edge marking and shoulders (RP).

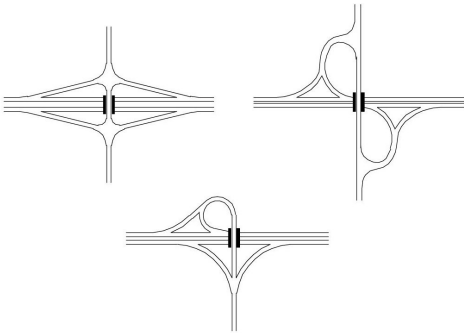
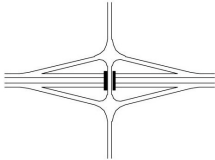
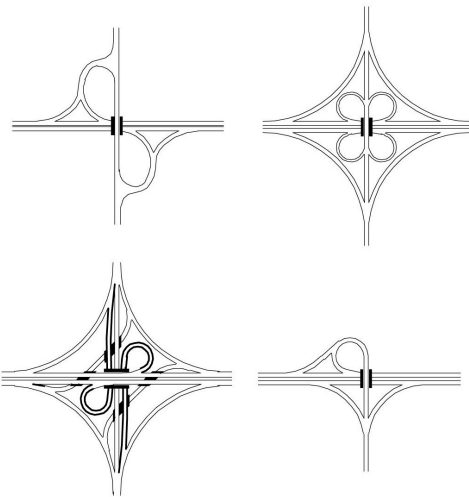
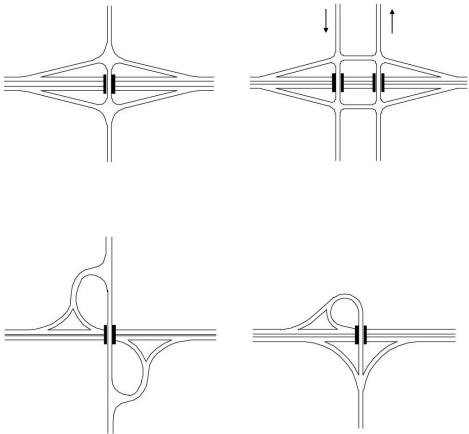
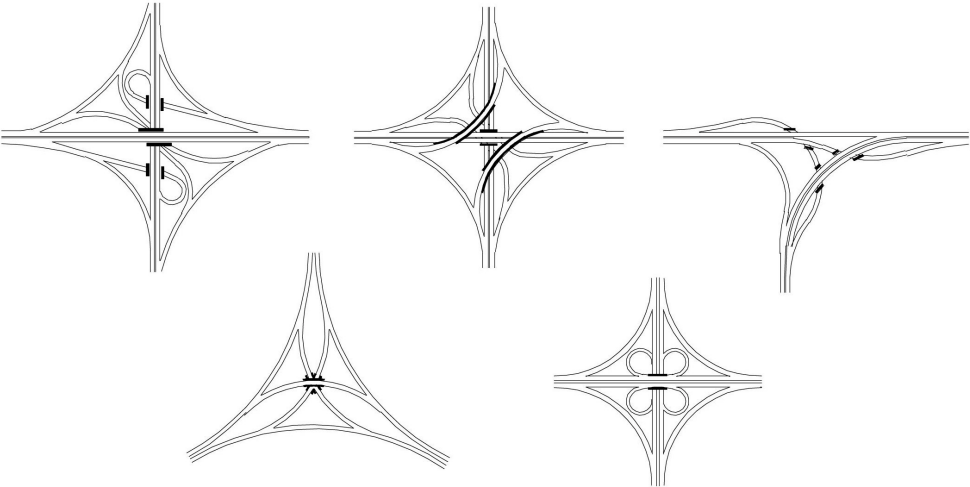
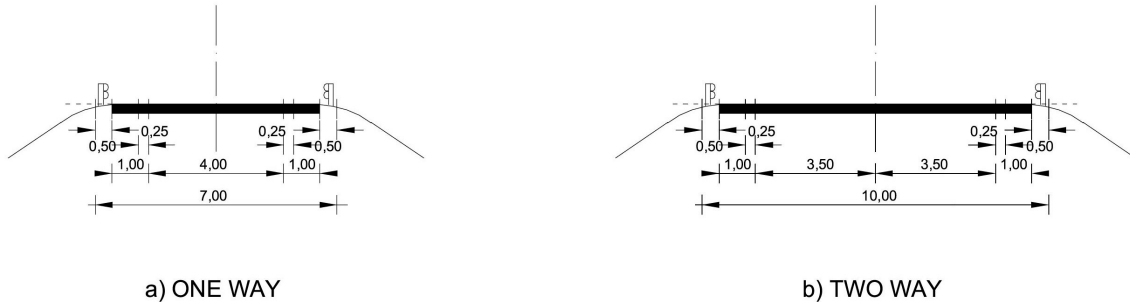

Fig. 3e - Cross sections of slip roads

3.3.4.2 The minimum requirements for horizontal and vertical alignment of slip roads are as follows (S):

minimum design speed:	40km/h
minimum radius on plane:	50 m
maximum gradient upwards:	7 %
maximum gradient downwards:	8 %
minimum radius of convex vertical curves:	800 m
minimum radius of concave vertical curves:	400 m

3.3.4.3 Within the convex and concave vertical curves the minimum stopping distance visibility should always be observed.

3.3.4.4 Horizontal curves should always be connected by means of a transition curve of suitable length.

### 3.3.5 Weaving Sections

3.3.5.1 It is recommended that weaving sections not located on the principal carriageway should have a minimum length of  $0.2Q$  (in metres),  $Q$  being the total weaving traffic in PCU/h (RP).

3.3.5.2 If, exceptionally, a weaving section cannot be avoided on a principal carriageway, the minimum length of such a section should be 500 m (RP).

3.3.5.3 The interchange should be so designed that, within its limits, the total weaving traffic is less than 2,000 PCU/h (RP).

### **3.3.6 Divergence of Traffic Flows**

3.3.6.1 Where a carriageway divides into two other carriageways, the separation of the two traffic flows must be effected in such a way as not to entail any significant reduction in the speeds of the vehicles (S).

3.3.6.2 To this end, the driver should have time to place himself in the lane most favourable for the direction he wishes to take, and must have sufficient visibility of the point of divergence (S).

3.3.6.3 In an A interchange, a carriageway which divides into two others should be widened before the separation, and must comprise a number of lanes equal to the number of lanes of the two carriageways over a distance which will allow the streams to separate before the point of divergence (S).

3.3.6.4 The widening should preferably be made to the right (RP). The less important traffic flow will have to leave via the right-hand carriageway so as to limit the number of vehicles decelerating while changing lanes. If the speed of this flow must be reduced, a deceleration lane should be provided. This right-hand carriageway should, if possible, be raised gradually with respect to the main carriageway to facilitate any deceleration and ensure better visibility of the divergence point (RP).

3.3.6.5 In a B interchange, the exit carriageway has to diverge towards the right and include a deceleration lane (S).

### **3.3.7 Convergence of Traffic Flows**

3.3.7.1 Where two carriageways converge to form a single one, the two traffic flows should be integrated in safe conditions and without significant vehicle speed reduction. To this end:

- (a) the drivers in the less important traffic flow have to merge from the right into the more important flow (S);
- (b) the driver who has to merge should have good visibility of the other carriageways before and beyond the convergence point. The merging manoeuvre, via acceleration lane where appropriate, should not entail appreciable speed reduction of the main flow. Visibility is improved and merging simplified if the carriageway carrying the merging flow slopes down slightly towards the other carriageway (RP);

- (c) it is also desirable to ensure good visibility from the main carriageway onto the other carriageway (RP);
- (d) where two main carriageways converge to form a single one, and where there is a reduction in the total number of traffic lanes, this reduction should be made at a sufficient distance from the point of convergence (RP).

3.3.7.2 In a B interchange, the entry carriageway onto a motorway or expressway carriageway has to converge from the right and include an acceleration lane (S).

### 3.4 Additional Lanes

#### 3.4.1 Scope

3.4.1.1 In order to maintain the desired service level over the motorway, additional lanes have to be constructed (S).

3.4.1.2 Particular situations - interchange or service area entries or exits, or sharp upward gradients - will necessitate separation of traffic flows of different operating speeds, to the point where the speed difference is practically eliminated (S).

#### 3.4.2 Acceleration Lanes

3.4.2.1 The acceleration lane of 3.50 m (cf. Figure 3f) has to permit entering vehicles to attain the operating speed of the outer motorway traffic lane and to merge into the flow in safety (S).

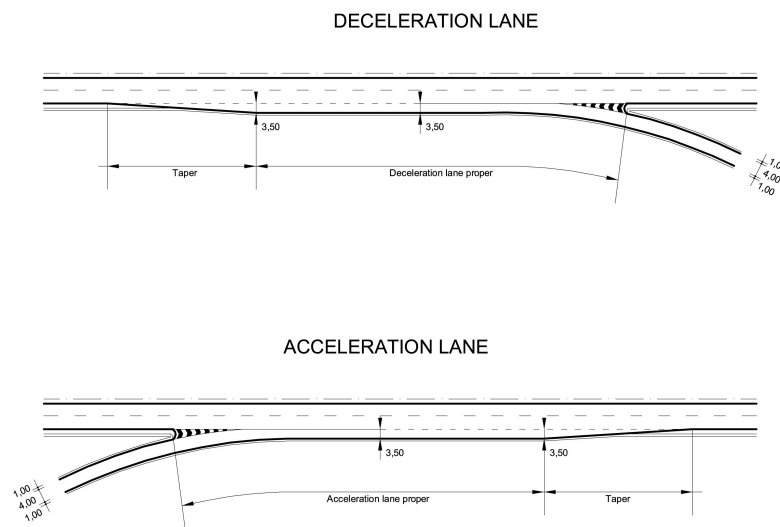

Fig. 3f - Acceleration and deceleration lanes

- 3.4.2.2 This lane consists of the acceleration lane proper, followed by a lane of variable width known as a taper (S).
- 3.4.2.3 The acceleration lane begins at the point of separation of the main carriageway and the slip road.
- 3.4.2.4 The length of the acceleration lane should be calculated on the basis of an average acceleration equal to  $0.6 - 0.8 \text{ m/sec.}^2$  (RP).
- 3.4.2.5 The length of the taper must be such as to permit the safe insertion of the vehicle into the traffic lane (S).
- 3.4.2.6 On straight and level alignments, the total length of the acceleration lane should not be less than 300 m, of which at least 200 m should be for the acceleration lane proper (RP).
- 3.4.2.7 For safety reasons the acceleration lanes should, wherever possible, be on a falling gradient (RP).

### **3.4.3 Deceleration Lanes**

- 3.4.3.1 The deceleration lane (cf. Figure 3f) has to permit the vehicle to exit, without significant reduction in speed, the traffic lane of the motorway, and to reduce its speed gradually down to the design speed of the exit ramp or of the service area involved (S).
- 3.4.3.2 The deceleration lane consists of lane of variable width (taper), followed by the deceleration lane proper (S).
- 3.4.3.3 The length of the taper should be calculated considering that the time necessary to carry out the manoeuvre is equal to 3.5 sec (RP).
- 3.4.3.4 The length of the deceleration lane is determined by assuming an average deceleration rate no greater than  $1.5 \text{ m/sec}^2$  (RP).
- 3.4.3.5 For safety reasons the deceleration lanes should, wherever possible, be on a rising gradient (RP).

### **3.4.4 Other Additional Lanes**

- 3.4.4.1 In all cases where the respective conditions set out in paragraph 2.2.2 occur, it would be advisable to construct an additional lane for fast vehicles, which is a preferable option, or a climbing lane for slow vehicles (RP).
- 3.4.4.2 The terminal sections of the said lanes must be of sufficient length to permit the respective vehicles to leave and re-enter the traffic lane in safety (S).

- 3.4.4.3 The additional or climbing lane must have a width of no less than 3.50 m (S).
- 3.4.4.4 If two successive additional or climbing lanes are less than 500 m apart, they should be combined (RP).
- 3.4.4.5 The minimum length of the additional or climbing lane should be 1,000 m (RP).

## **3.5 Pavements**

### **3.5.1 Scope**

The standards provide the general criteria for the design and construction of flexible, semi-rigid and rigid types of pavements to be used on the TEM and related parts of interchanges, rest areas, service areas etc., in such a fashion as to have a uniform carrying capacity throughout its route or the means to obtain this economically at subsequent stages.

### **3.5.2 Factors Influencing Structural Design**

3.5.2.1 The main factors which can affect the performance of pavements and which should be taken into account in the design are as follows:

- (a) traffic loading (paragraph 3.5.2.2);
- (b) subgrade (paragraph 3.5.2.3);
- (c) hydrological conditions (paragraph 3.5.2.4);
- (d) climatic conditions (paragraph 3.5.2.5);
- (e) materials (paragraph 3.5.2.6).

#### **3.5.2.2 Traffic Loading**

3.5.2.2.1 Traffic loading is the principal pavement design factor. It is defined in terms of the cumulative number of standard axles to be carried by the lane with the most traffic during the design period of the motorway.

3.5.2.2.2 In pavement design methods, traffic loading is defined also in terms of the average daily number of standard vehicles per the most trafficked lane.

3.5.2.2.3 The standard axle is a minimum 115 kN single axle with two assemblies of twin tyres (RP).

- 3.5.2.2.4 A standard vehicle is a two-axle commercial vehicle with single tyres on the front axle and twin tyres on the rear axle. The rear axle is loaded to minimum 100 kN (RP).
- 3.5.2.2.5 The design period is the number of years from the initial application of traffic until major strengthening is anticipated. It is recommended that a flexible pavement be designed for a period of 20 years (RP).
- 3.5.2.2.6 For rigid pavements, the design period should never be less than 20 years, but longer lives of up to 40 years may be selected, based on technico-economical considerations and available experience (RP).
- 3.5.2.3 Subgrade
- It is recommended that soils be classified according to the Unified Soil Classification System (USCS). The bearing capacity of the subgrade may be assessed by the California Bearing Ratio (CBR) value, the modulus of subgrade reaction ( $k$ ), the modulus of elasticity ( $E$ ) or the modulus of deformation ( $M_E$ ) (RP).
- 3.5.2.4 Hydrological Conditions
- 3.5.2.4.1 Hydrological conditions influence the thickness of the pavement structure if the subgrade consists of frost and water susceptible soils; these conditions are estimated on the basis of the depth of the ground water table below the pavement surface. For the purpose of structural design, the minimum depth obtained from records covering a minimum of 10 years for drainage conditions should be applied (RP). The design moisture content of the subgrade soil depends on the conditions of run-off of surface water, climatic conditions, shoulder permeability and drainage; it is also a function of the hydrological conditions. It is the maximum moisture content which can occur in the most unfavourable moisture conditions for the pavement.
- 3.5.2.4.2 Wherever practicable, the water table should be prevented from rising to within 500 mm of the formation level (upper part of the subgrade) either by subsoil drainage or by raising the formation level by means of an embankment. It is important to provide efficient permanent drainage to remove water from the subgrade and sub-base.
- 3.5.2.5 Climatic Conditions
- 3.5.2.5.1 Because of the very high costs of frost barriers or of frost damage to the pavement, the pavement has to be designed to avoid frost barriers and frost damage. Climatic conditions are assessed



mainly by means of the Freezing Index ( $FI_D$ ), the depth of frost penetration and extreme air temperatures (RP).

3.5.2.5.2 Sufficient care should be exercised in countries where considerable rainfall is likely during the construction period since wet weather can rapidly reduce the strength of exposed subgrade to values lower than those assumed as the basis of pavement design (RP).

3.5.2.6 Materials

National methods concerning the assessment of properties of materials on-site compaction and bearing capacity control apply.

### **3.5.3 Design Methods**

3.5.3.1 The calculation of pavement layer thickness differs essentially from such calculations regarding other structures (bridges, buildings, etc.), since no method has yet been developed for use in all countries and in all situations. Various design methods in use may be classified as empirical, semi-empirical and theoretical.

3.5.3.2 Accordingly, it is left to the designer to choose the most suitable method for dimensioning pavements from among the many which have been developed in recent years.

3.5.3.3 For rigid pavements, wearing course of plain or reinforced cement concrete consisting of one or two layers should be taken into account.

## **3.6 Slipperiness and Evenness**

### **3.6.1 Scope**

The motorway pavements have to have high safety levels, especially with respect to slipperiness and aquaplaning (S).

### **3.6.2 Geometric Characteristics**

3.6.2.1 The crossfall on straight sections shall never be less than 2% (S). On section where the crossfall is reversed (for example, on passages between straight and curved sections and between curves in opposite directions), the zones with crossfall of less than 2% have to be of minimum length (S).

3.6.2.2 To avoid zones of this nature, it is recommended that the solution shown in Figure 3g be adopted (RP).

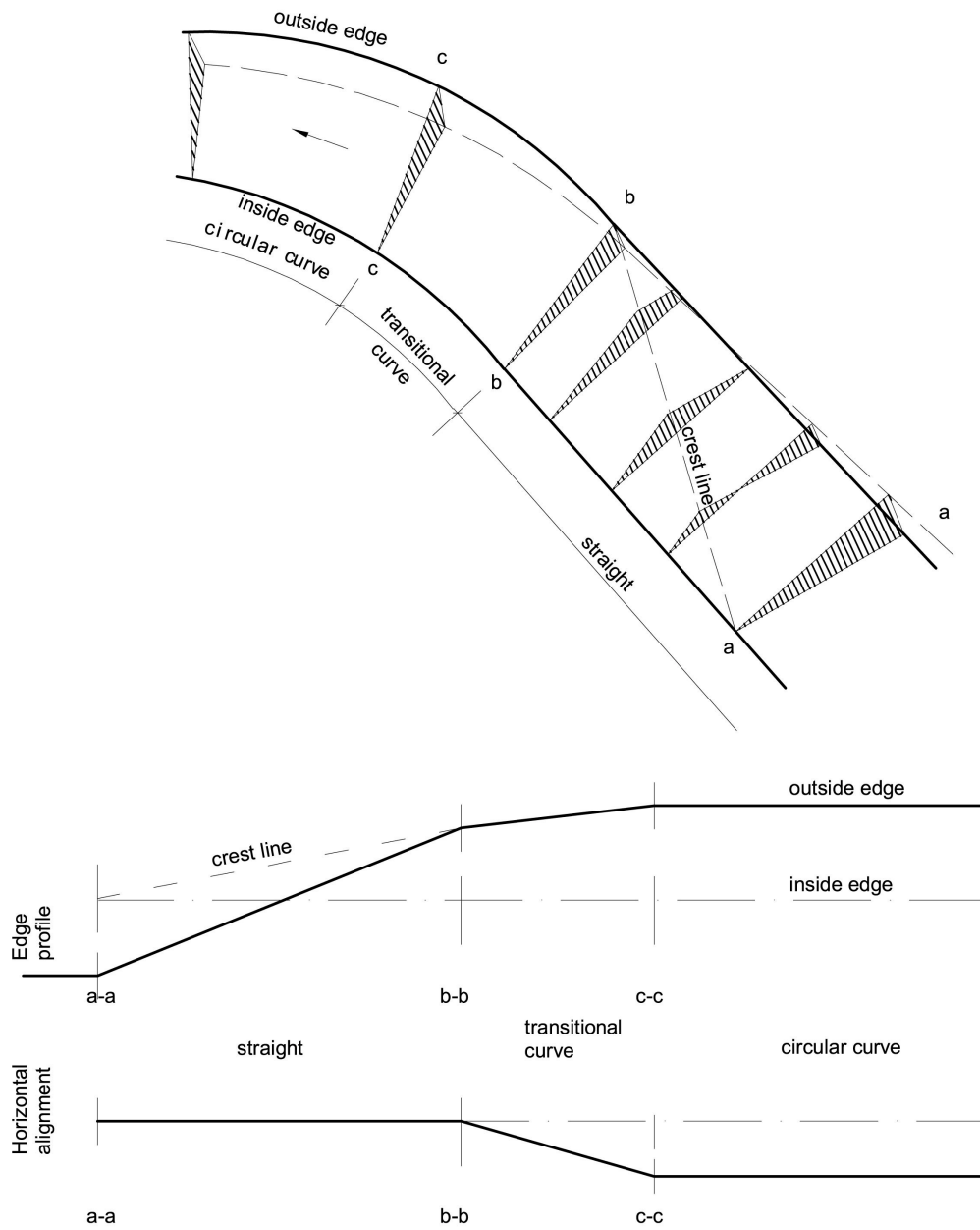

Fig. 3g - Crossfall changeover scheme

3.6.2.3 This solution shall be adopted also on bridges where the longitudinal gradient within these zones should not be lower than 0,5% (RP).

### **3.6.3 Slipperiness**

3.6.3.1 Slipperiness should be avoided taking account of the fact that surface roughness is the result of both the projections of the pavement aggregates (macro-texture) and the microscopic roughness of the surfaces of the aggregates themselves (micro-texture). The respective measurement method is governed by the European Standard EN-13036-4 “Pavement Surface Characteristics – Test Methods – Part 4: Method for Measurement of Skid Resistance of Pavement Course”.

3.6.3.2 Aggregates used in mixes for pavement surface layers must have the desirable roughness and maintain it over time (S).

### **3.6.4 Evenness**

3.6.4.1 The surface evenness can be measured using various methods. The tolerances permitted should be established on the basis of the functional characteristics of the respective equipment. The respective measurement method governed by the European Standard EN – 13036-7 “Pavement Surface Characteristics – Test Methods – Part 7: Measurement of Single Irregularities”.

3.6.4.2 The same methods may also be used during maintenance of the motorway to evaluate the progressive degradation of pavement quality.

## **3.7 Drainage Systems for Surface and Subsoil Water**

### **3.7.1 Scope**

The standards provide general criteria for the design and construction of systems for the drainage of surface and subsoil water to avoid accumulation of standing water and to collect and carry away water present in the immediate foundation zone of the motorway.

### **3.7.2 Parameters for System Design**

To determine the correct dimensions, in hydraulic terms, of the surface water drainage systems, it is necessary to calculate the total flow which these systems will convey, and hence to obtain certain basic data, of which some of the most important are:

- (a) extent of catchment area;
- (b) maximum foreseeable rainfall intensity;
- (c) recurrence time;
- (d) nature of soils and runoff coefficient;
- (e) geotopographical characteristics and concentration time.

**3.7.3 Systems of Drainage for Surface Water**

3.7.3.1 Types

The collection and discharge of surface water (rain or snow melt) from the carriageway surface and from embankments and cuts may be done by means of the following devices:

- (a) pavement drains;
- (b) side channels and ditches;
- (c) slope protection ditches;
- (d) gutters;
- (e) sumps.

3.7.3.2 Location

3.7.3.2.1 For the position of these systems with respect to the motorway cross section, see the cross sections shown in Figure 3h.

3.7.3.2.2 The following table shows the minimum desirable dimensions for the geometric elements indicated with the corresponding letters in Figures 3h and 3i, along with the minimum longitudinal slope (i%) of the drainage pipes (RP):

Table 3g

A min	B min	h (cm)	h <sub>1</sub> (cm)	i (%)
30	50	40	15	0,3

3.7.3.3 Pavement Drainage

Pavement drainage systems have to maintain over time the bearing capacity of the lower layers of the pavement and are essential in case of subgrade soils which might be affected by the presence of water.

3.7.3.4 Side Channels and Ditches

3.7.3.4.1 Figure 3i shows various options regarding side channel cross sections.

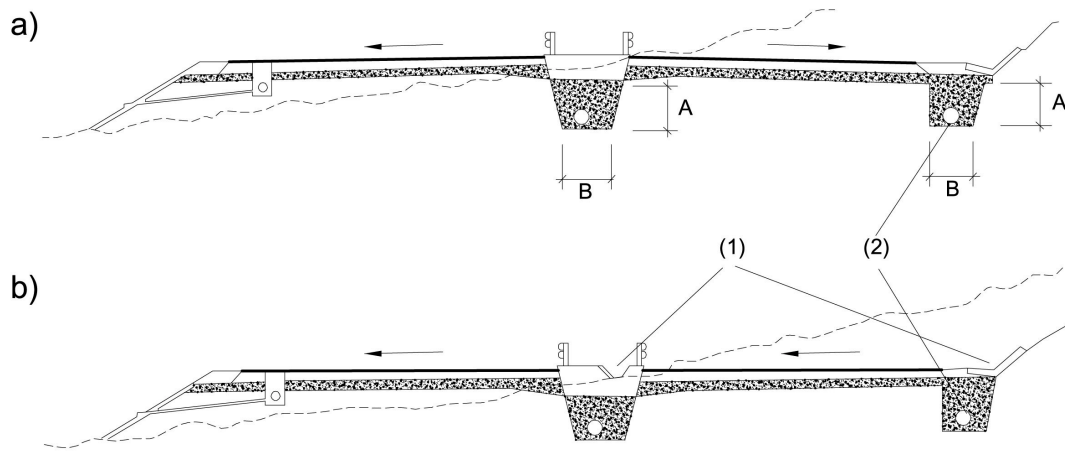

*Fig. 3h - Location of surface water disposal devices and pavement drains:  
 (a) on the straight  
 (b) on the curve  
 Also indicated is the location of possible subgrade drainage in the embankment:  
 (1) side channel  
 (2) drain*

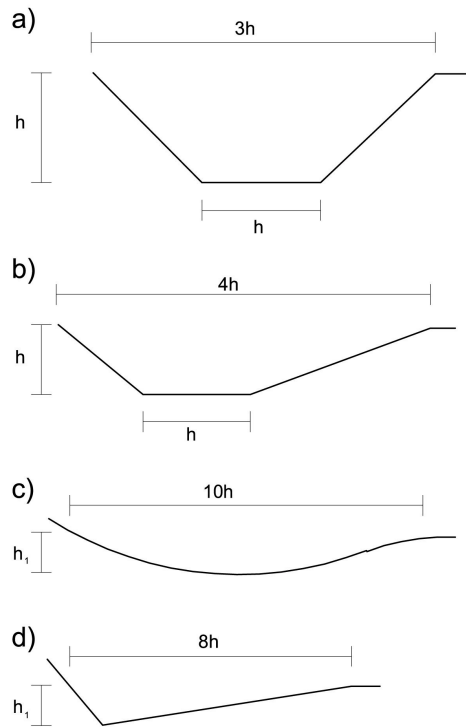

*Fig. 3i - Cross sections of systems for drainage of surface water:  
 side channels and ditches*

- 3.7.3.4.2 When cross sections a) and b) are used, a safety fence should be installed on the outer edge of the carriageway (RP).
- 3.7.3.4.3 Cross sections c) and d) are suitable for limited flows, and normally require the installation of collectors below them (RP).
- 3.7.3.4.4 Cross section a) is employed in case of ditches.
- 3.7.3.4.5 Cross section d) should preferably be lined with cement concrete.
- 3.7.3.4.6 In case of side channels in cuts, a constant width over the whole length is normally assumed, whereas the longitudinal slope follows that of the road itself.
- 3.7.3.4.7 In addition to channels and ditches, pipe drains may be installed to protect the motorway formation from subsoil water.
- 3.7.3.5 Slope Protection Ditches
- These ditches are located near the top edge of the cut slope or at the bottom edge of the embankment slope to catch water approaching these slopes. Both types of ditches could be of triangle or trapezoid cross section and usually unpaved. Where necessary, however, the bottom of the ditch may be covered by cement or ceramic tiles.
- 3.7.3.6 Paved Gutters
- 3.7.3.6.1 Paved gutters are formed of flat, suitably shaped prefabricated cement or ceramic tiles.
- 3.7.3.6.2 These gutters extend all the way up the sides of the embankment slopes, from the ditch along the foot up to the shoulders, where they are connected with the pavement surface by means of special outlets shaped in such a way that the water encounters no obstacles, and no eroding flows are created. Every third or fourth tile of the channel should be anchored – for example, with pairs of steel rods driven into the soil – in such a way as to prevent slippage of the tiles (RP).
- 3.7.3.6.3 So as to ensure regular disposal of rainwater from the pavement surface, it is suggested that channels be spaced at intervals of about 30 m (RP).
- 3.7.3.7 Sumps
- 3.7.3.7.1 Normally, the surface water collected by the gutters, ditches and side channels is conveyed to nearby natural gullies and thence away from the vicinity of the motorway, or into pre-existing collectors of suitable capacity.

- 3.7.3.7.2 Where absolutely flat topography precludes this, it is possible to utilize drainage sumps. It is advisable not to exceed a ratio of 1 ha of catchment area per sump. However, where the catchment area consists solely of the carriageway and its associated slope, the optimum distance between sumps can in practice be around 400-500 m (RP).
- 3.7.3.8 Culverts
- 3.7.3.8.1 The clear span of a single tube culvert does not normally exceed 3 m; where the amount of discharge so requires, it is possible to employ multiple culverts consisting of two or more flanking tubes.
- 3.7.3.8.2 The materials generally utilized in constructing culverts include cement concrete, steel tubes or sheeting, corrugated metal or plastics; where economical, it is also possible to construct them of masonry.
- 3.7.3.8.3 The circular cement concrete culverts consist of prefabricated tubes, generally reinforced and covered with graded fill material. From the static standpoint, they are sized in accordance with the permanent loads (backfill) and the incidental loads (forecast traffic loads).
- 3.7.3.8.4 Culverts of corrugated sheet consist of circular cross-section tubes or, for larger spans, of shaped corrugated sheets which are assembled on site to achieve the desired sections.
- 3.7.3.8.5 To limit the action of traffic on the structure, it is advisable that the uppermost surface of the tube be located at least 60 cm below the lower surface of the pavement.
- 3.7.3.8.6 Box-type culverts are constructed with square or rectangular cross sections.
- 3.7.3.8.7 To protect the motorway formation itself and the surrounding soils from erosion, and to channel the water into the culverts with greater hydraulic efficiency, it is necessary to provide the intake and outlet of the culvert with suitable protective side and wing walls.
- 3.7.4 Systems of Drainage for Subsoil Water**
- 3.7.4.1 From the hydrogeological point of view, water present in the immediate subsoil can be generally classified as follows:

- (a) percolating water and infiltration via cracks and or stratification joints in the soil;
- (b) ground water;
- (c) capillary water.

3.7.4.2 In order to design adequately drainage works, it is necessary to have data regarding various aspects, such as:

- lithography and stratigraphy of the basin;
- location and flow of possible water tables;
- surface slope of soil;
- etc.

3.7.4.3 Types and Nomenclature

Depending on the possible effects of the subsoil water, i.e., whether it directly affects the motorway structures, causes slippage of slopes which could, in turn, affect the motorway, or increases the compressibility of soils used in the embankment, the measures to be adopted can be classified as follows:

- (a) measures to prevent subsoil water affecting the motorway formation: drainage trenches, drains behind retaining walls, drainage conduits, anti-capillary layers;
- (b) measures to prevent subsoil water from weakening unstable slopes: sub-horizontal drainage, drainage tunnels, drain wells, submersible pumps;
- (c) measures to prevent subsoil water from destabilizing compressible foundation soils: well points, sand piers.

3.7.4.4 Drainage Trenches

3.7.4.4.1 The main function of drainage trenches is to eliminate capillary and percolating water from within the body of the slope.

3.7.4.4.2 They can be used to advantage especially in cohesive soils with a high water content to allow evaporation of excess water.

3.7.4.4.3 Together with the dry fill or stone material, perforated pipes can be laid for drainage along the bottom of the trench.

3.7.4.5 Back-Wall Drainage

3.7.4.5.1 Back-wall drainage represents a particular variant of the drainage trench.



- 3.7.4.5.2 Such drains are constructed behind retaining walls and serve the purpose of relieving the intergranular water pressure. It is always necessary to ensure regular longitudinal drainage of the water gathering at the bottom of the drain, by means of dished concrete beds or a slotted pipe inserted in the filter material.
- 3.7.4.5.3 It is advisable to provide also for transverse water disposal using weepholes spaced at intervals no greater than 1.5 m on the vertical and every 2-4 m on the horizontal.
- 3.7.4.5.4 The upper part of the drain should be carefully waterproofed by means of a protective layer of clay, concrete, bitumen, etc.
- 3.7.4.5.5 It is also advisable, in order to provide added waterproofing for the wall, to create an upper ditch or channel to collect the runoff from the slope and channel it to the ends of the wall.
- 3.7.4.6 Anti-Capillary Layers
  - 3.7.4.6.1 Capillary action in water-bearing soils is linked with molecular tension phenomena at the water/air interface in the zone immediately overlying the water table.
  - 3.7.4.6.2 The rise in level is inversely proportional to the porosity of the ground, and may reach 2 to 3 m in highly silty soils, thus penetrating into motorway embankments. In such cases it is desirable to provide an anti-capillary curtain over the foundation soil, composed of clean, compacted granular material, constituting a layer of all-in grain size ranging from a minimum of 2 to maximum of 50 mm; from 30 to 60 cm thick, this layer should extend beyond the perimeters of the embankment (RP).
- 3.7.4.7 Sub-Horizontal Drainage
  - 3.7.4.7.1 Sub-horizontal drainage is normally employed when the slip surface of the soil is of limited depth (by way of indication, less than 6 to 7 m below surface level).
  - 3.7.4.7.2 Before performing the drainage, the slope is suitably prepared, taking into account the gradient and the state of the ground (see Table 3h for typical examples):

Table 3h  
Recommended Preparatory Measures Prior  
to Performing Drainage

Gradient	Stability of Surface of Ground	Preparatory Measures Prior to Drainage
Slight	Good	None
Slight	Poor	Anti-erosion system of synthetic material or metal screen, and subsequent seeding with grass.
Average	Poor	Surfacing with prefabricated concrete slabs, possibly anchored down.
Steep	Poor	Containment of slope foot with reinforced concrete walls and simultaneous formation of guide pipes.

- 3.7.4.7.3 The guide holes are rotary-drilled, with an upward incline of between 5° and 30°.
- 3.7.4.7.4 When drilling is complete, a semi-rigid PVC pipe, 40 to 50 mm in diameter, is inserted through the whole length of the bore hole.
- 3.7.4.7.5 The pipe may be micro-perforated or perforated and coated with nonwoven fabric.
- 3.7.4.8 Measures to speed Up the Consolidation of Subsoil
- 3.7.4.8.1 Vertical sand drains speed up consolidation of embankment support soils and may be provided by covering the ground with bore holes, normally from 300 to 500 mm in diameter.
- 3.7.4.8.2 These fulfil their function at a certain depth, where the overlying loads generate increased interstitial pressure.
- 3.7.4.8.3 The sand piles are considerably more permeable than the surrounding soil, and at the same time exert a strong capillary action. The piles are generally at the vertices of a network of equilateral triangles, the side lengths of which depend on the permeability of the soil and the rate of consolidation required (RP).

3.7.4.8.4 Vertical drains feed into a horizontal drain consisting of a drain layer some 40 to 70 cm thick.

3.7.4.9 Filter Materials

3.7.4.9.1 The granular materials used in the filters covering the drain conduits or lining the drainage ditches must be of such a nature as to prevent filter clogging.

3.7.4.9.2 The important feature to be checked in these materials is their grading. The grading of the material making up the filter must be in relation to the granulometric characteristics of the surrounding material and to the size of the holes in the drains.

### **3.7.5 Water Catchment and Pollution Prevention Measures and Facilities**

3.7.5.1 General

In order to catch the foul water leaving the motorway and prevent it from polluting the watercourses, these facilities and measures may be used:

- (a) monolithic sedimentation reservoirs;
- (b) natural catchment basins;
- (c) biological purification;
- (d) sorption filters.

3.7.5.2 Monolithic Sedimentation Reservoirs

Monolithic sedimentation reservoirs, which may also be prefabricated, make use of sedimentation and gravitational separation of pollutants. Their capacity should be at least 30 m<sup>2</sup> (RP) and they may also be provided with sorption filters. In cases they not allow for free passage of amphibia, the suitable escape routes for them should be made available (RP).

3.7.5.3 Natural Catchment Basins (Sedimentation Lagunas)

3.7.5.3.1 Apart from sedimentation and gravitational separation, these facilities make use also of biological purification processes.

3.7.5.3.2 They are located either on the existing watercourses or – preferably – aside from them. The basin should be waterproof and at its inlet and outlet respective measures should be taken to prevent oil or other pollutants' leakages.

3.7.5.4 The following two facilities serve the purpose of additional purification in cases where the compliance with the respective

water pollution limits cannot be guaranteed by the basic facilities described above only. The precondition for their long time correct performance is the efficient catchment of solid particles at the preceding purification stage.

3.7.5.4.1 Biological Purification

This type of purification is carried out by earth filters or artificial swamps. Earth filters make use of bacterial metabolism, while swamps take advantage of metabolisms of plants mostly. These purification processes, however, are not effective in cases of substantial oil leakages; on the contrary, such facilities could be seriously damaged or destroyed by great amounts of such pollutants.

3.7.5.4.2 Sorption Filters

Sorption (fiberoil) filters are capable of detaining oil products of concentrations below the limits of gravitational separation (2 – 5 mg/l). They are located in the last section of sedimentation reservoirs or beyond them. Their design should make it possible to replace the filters easily. With regard to relatively high operation costs it is recommended to use them only in cases of well documented need (RP).

**3.8 Connections to TEM**

**3.8.1 General Concept**

3.8.1.1 Route

3.8.1.1.1 The choice of a connecting route should respect the following principles:

- (a) sections in urban zones should be kept as short as possible;
- (b) city centres, business districts and residential zones shall be avoided in urban areas.

3.8.1.1.2 It is recommended that there be only one route linking the TEM and the port or the industrial zone. Continuity will be achieved by ensuring that the user can easily find the route to follow, especially in transition zones (from rural to urban), with clear signs and markings homogeneous with those of the TEM.

3.8.1.2 Traffic

3.8.1.2.1 For such connections, the number of lanes necessary at the final stage will depend on long-term traffic forecasts based on surveys, studies and hypotheses regarding traffic development over time.

3.8.1.2.2 Analysis of short and medium-term growth will permit possible construction in stages.

**3.8.2 Design Specifications for TEM Connections**

3.8.2.1 Connections should be designed taking into account the different types of environment along the route.

3.8.2.2 The following types of road may be considered:

- (a) connections in rural areas with design speeds of 120, 100 or 80 km/h. As extensions of the TEM, these connections should have similar geometric characteristics and provide the same level of service as the TEM (RP);
- (b) urban or suburban express roads with design speeds of 100 or 80 km/h. These have geometric characteristics and service levels similar to those above, but with greater functional interaction between them and the surrounding zone. They carry a greater proportion of exchange traffic, and should have more frequent interchange points (RP);
- (c) urban roads with design speeds of 80 or 60 km/h. These should have frequent interchange points so as to provide good access to the urban zones concerned (RP).

3.8.2.3 Alignment

The choice of design speed and longitudinal section must take into account the terrain and land use of the zones involved, so as to adapt the design parameters to the construction costs. National standards for rural and local roads apply in these cases.

3.8.2.4 Specific Measures for Port Roads

3.8.2.4.1 By way of information, it is possible to specify certain design features of port roads. Where only port traffic is authorized, the roads may consist of a 2-lane carriageway. Given the type of traffic (heavy vehicles going to and from the port – heavy vehicles awaiting port transit – haulage equipment), each single lane should be 3.75 m in width.

3.8.2.4.2 In the case of one-way traffic, the carriageway shall be 5 m in width.

- 3.8.2.4.3 The alignment of port roads should be as direct as possible. The characteristics adopted generally correspond to a design speed of 40 km/h, the design parameters being given in Table 3i:

Table 3i

Minimum Design Parameters for Port Roads

Design Speed (km/h)	Minimum Radius on Plane (m)	Maximum Gradient (%)	Minimum Convex Radius (m)	Minimum Concave Radius (m)	Minimum Stopping Distance (m)
40	40	8	500	700	40

- 3.8.2.4.4 Where possible, drawbridges and level crossings with railways should be avoided.
- 3.8.2.4.5 Various port installations (container terminals, carriers, warehouses) should be clearly marked to avoid unnecessary movement of freight vehicles looking for their destinations. Parking on port roads should be prohibited.

### 3.8.3 Traffic Signs and Equipment

Indications regarding road markings and signs, light signals, safety devices and fences, emergency communications systems, etc., are given in Chapter 4.

### 3.8.4 Environment

Measures to be taken to restrict to the minimum negative effects on the environment and the surrounding population are set out in Chapter 6.

## **4 TRAFFIC REGULATION AND SAFETY FACILITIES**

### **4.1 General Characteristics**

#### **4.1.1 Scope**

4.1.1.1 The following standards refer to motorway signs and markings of whatever type to be installed on the TEM and its appurtenances (S).

4.1.1.2 These motorway signs and markings include markings (horizontal signs) and vertical signs, traffic lights and supplementary signs and markings (S).

4.1.1.3 For whatever is not expressly regulated by the present standards, it is suggested to consult the 1968 Convention on Road Signs and Signals and the 1971 European Agreement Supplementing It <sup>(1)</sup>, henceforth abbreviated as the Vienna Convention.

#### **4.1.2 Harmonisation**

4.1.2.1 Harmonisation is the essential requisite for the TEM motorway signs and markings (S).

4.1.2.2 The symbols and letterings used must be identical to those prescribed, except, of course, for the differences in size, according to the shape and size of the sign or marking itself (S).

4.1.2.3 Also the proportions between the symbols and the colour zones, and between the lettering and the background must be kept constant for all signs or markings of the same type, whatever their size (S).

#### **4.1.3 Location**

4.1.3.1 Motorway signs and markings are directed at drivers of high speed vehicles, and thus must be visible from a great distance and be instantly intelligible.

4.1.3.2 These signs and markings must be installed in such a way as to prompt a quick driver response.

---

(1) UN Economic Commission for Europe document No. E/CONF.56/17/Rev.1/Amend.1, incorporating also the amendments to the Convention which entered into force on 30 November 1995 and document No. E/ECE/812-E/ECE/TRANS/566-Amend.1

4.1.3.3 It is important to avoid abusing the sign systems, e.g. by crowding together a number of signs without adequate spacing.

#### **4.1.4 Colour**

4.1.4.1 The colours to be used for motorway signs and markings should be red, blue, green, yellow, brown, white and black, as specified subsequently.

4.1.4.2 The chromatic coordinates must be clearly defined (S).

#### **4.1.5 Reflectorisation**

4.1.5.1 It is advisable that motorway markings be retro reflectorised (RP).

4.1.5.2 Motorway signs, wherever these are not lit either by transparency or by external lighting, must be retro reflectorised (S).

4.1.5.3 It is important that the materials used for this purpose have suitable characteristics.

## **4.2 Motorway Markings**

### **4.2.1 General Requirements**

#### **4.2.1.1 Scope**

4.2.1.1.1 Motorway markings must be provided on the motorway carriageways and appurtenances (service areas, interchanges, filling stations, etc.).

4.2.1.1.2 Motorway markings include:

- (a) longitudinal lines: lane lines and edge markings, oblique connecting and channelling lines;
- (b) transverse lines: slowdown and stop lines at toll stations;
- (c) other lines: directional arrows, chevron markings, lettering, etc;
- (d) catseyes;
- (e) jiggle bars.

#### **4.2.1.2 Materials**

4.2.1.2.1 Motorway markings must be skid-resistant under both wet and dry conditions (S).

4.2.1.2.2 Wherever studs or similar devices are used, these must not exceed 10 mm in thickness (S).



- 4.2.1.3      Colour
- Permanent motorway markings should (with a possible exception of catseyes – see paragraph 4.2.2.4) be white (RP).
- 4.2.1.4      Accordance with Motorway Signs
- Motorway markings must harmonize with motorway signs so as to reinforce and clarify their meaning (S).
- 4.2.2      Special Requirements**
- 4.2.2.1      Longitudinal Lines
- 4.2.2.1.1      Continuous and Broken Lane Lines
- Continuous lines will be used on two-way slip roads and on two-way carriageways to separate the opposing traffic streams where overtaking is forbidden (S). These lines will have a minimum width of 12.5 cm (S).
- Broken lines mark the limits of the lanes to channel the traffic (S). The length of the gaps must be twice that of the line segments (S). A length of 6 m is suggested for the line segments and of 12 m for the gaps (RP). Broken lines will have a minimum width of 12.5 cm (S).
- 4.2.2.1.2      Carriageway Edge Markings
- Motorway carriageway must be delimited by continuous lines of no less than 15 cm in width (S).
- In case of separation between traffic lanes and the acceleration or deceleration lanes, a broken line must be used (S).
- 4.2.2.1.3      Oblique Connecting and Channelling Lines
- On the tapers of the acceleration and deceleration lanes and in certain zones of the ancillary areas, the longitudinal lines will be oblique, and accordingly of increased width (S).
- 4.2.2.2      Transverse Lines
- In the plazas preceding toll booths (in case of a toll motorway), at motorway exits and elsewhere, transverse lines should be painted of decreasing width and distance as one approaches the toll collection point (RP).

4.2.2.3 Other Motorway Markings

4.2.2.3.1 Lane Selection Arrows

Lane selection arrows should be painted on the traffic lane indicating the taper of the deceleration lanes of interchanges, service areas and rest areas (RP).

The shape and size of these arrows will be in conformity to the Vienna Convention (S).

4.2.2.3.2 Re-Entry Arrows

At the ends of the additional lanes, e.g. climbing lanes, no fewer than three warning arrows must be painted, to indicate the need to re-enter the traffic lane (S).

The shape and size of these arrows will be in conformity with the Vienna Convention (S).

4.2.2.3.3 Chevron Markings

A series of parallel chevron markings on a pavement zone, surrounded by a continuous line, indicates that the zone is closed to traffic. The parallel lines should be so aligned with respect to the direction of traffic as to direct the traffic away from the area so defined (RP).

Markings of this type must be used at points of converging traffic and preceding traffic islands (S).

The lines must never be less than 0.15 m in width (S).

4.2.2.3.4 Lettering and Symbols

Lettering and symbols on the pavement of the motorway carriageways must be limited as far as possible to a single row (RP).

The dimensions, considerably lengthened to take into account the low angle of sight and the approach speed, must be in conformity with the Vienna Convention (S).

4.2.2.4 Catseyes

4.2.2.4.1 Catseyes (retroreflecting buttons) may be used to support the ordinary motorway markings.

4.2.2.4.2 The recommended spacing of catseyes is generally 18 m (RP). Their spaces may be shorter where they separate traffic and

acceleration or deceleration lanes or where there is an increased safety risk (frequent fog occurrence, sharp curves of interchange slip roads, etc.).

4.2.2.4.3 The colour of catseyes located on the longitudinal lines separating traffic lanes is white (S). The catseyes marking the edge of the carriageway or performing other functions (e.g. ice formation warning) could be of different colour, such as amber (left carriageway edge), green or blue (RP).

4.2.2.5 Jiggle Bars

The usage of jiggle bars (carriageway edges having specially shaped surface to provide sound warning in case of out-of-control vehicles leaving the carriageway) is recommended to increase traffic safety (RP).

## **4.3 Motorway Signs**

### **4.3.1 Scope**

4.3.1.1 Motorway signs may be divided into the following categories:

- (a) danger warning signs: these signs are intended to warn motorway users of a danger on the road and to inform them of its nature;
- (b) regulatory signs: these signs are intended to inform motorway users of special obligations, restrictions or prohibitions with which they must comply; they are subdivided into:
  - priority signs;
  - prohibitory or restrictive signs; and
  - mandatory signs.
- (c) informative signs: these signs are intended to guide motorway users while they are travelling or to provide them with other information which may be useful; they are subdivided into:
  - advance signs;
  - direction signs;
  - motorway identification signs;
  - place identification signs;
  - confirmatory signs;
  - other signs providing useful information for drivers;
  - other signs indicating facilities which may be useful to motorway users.

4.3.1.2 The first two categories are not governed by these standards. The designer is referred to the Vienna Convention, with the recommendation to use larger dimensions: triangular signs with sides of 1.20 m and circular signs with minimum diameter of 0.90 m.

4.3.1.3 The standards which follow deal essentially with the third category, i.e. informative signs, which are of considerable use and great importance on motorways. The signs in this category also should conform with the Vienna Convention.

#### **4.3.2 General Requirements**

##### 4.3.2.1 Perception

4.3.2.1.1 Motorway signs must attract attention and be easily distinguishable within their surroundings (S).

4.3.2.1.2 The dimensions of the signs must be such that they are easily visible at a distance and can be easily interpreted by drivers approaching at speeds equal to the maximum permitted on the motorway section under consideration (S).

4.3.2.1.3 Thus, the dimensions of the signs on the interchange link and slip roads may be smaller than those installed on the main motorway carriageways (RP).

##### 4.3.2.2 Legibility

4.3.2.2.1 Signs must contain only essential information, and their meaning must be clear at a glance, so that the driver's attention is not distracted from driving (S). Good legibility depends mainly on the length of the message, and on the size and types of characters used.

4.3.2.2.2 Legibility of permanent signs on the motorway must be guaranteed at a distance of at least 150 m from the point of installation (S).

4.3.2.2.3 The alphabet used is the Latin one (S). When the alphabet used in the country crossed by the motorway differs from the above, the former may be used beneath the Latin alphabet text (RP).

##### 4.3.2.3 Length of Message

It is advisable that the motorway signs contain no more than 4 – 5 lines of text (RP).

##### 4.3.2.4 Position of Message

The legibility of the message depends on its length relative to its background and on a suitable proportioning of the margins between the ends of each line of wording and the edge of the sign border.

- 4.3.2.5 Consistency of Wording
- 4.3.2.5.1 The general principle should be followed of using and repeating the same wordings or local names along a given route (RP).
- 4.3.2.5.2 Names of destinations should be written in the respective national language(s) (RP).
- 4.3.2.6 Inscriptions
- The use of words should be avoided as far as possible, in favour of international symbols intelligible to drivers of diverse nationalities.
- 4.3.2.7 Background Colour (1)
- The colour of the background of the informative signs should be green, except in the following cases (RP):
- (a) direction signs referring to ordinary road systems or to localities to be reached via such roads; in this case the background should be blue;
  - (b) tourist signs; these should have a yellow background;
  - (c) additional panels (cf. paragraph 4.3.2.9); these should have a white background.
- 4.3.2.8 Dimensions
- 4.3.2.8.1 Informative signs, except for arrows and on gantries (dealt with in separate paragraphs) will have minimum dimensions as shown in the table below, which shall be commensurate with the intelligibility requirements of the message (S).
- 4.3.2.8.2 At the more important exits or interchanges with other motorways, the use of enlarged dimensions is recommended (RP):

Table 4a

Minimum Dimensions of Informative Signs

Dimensions	Normal (m)	Enlarged (m)
Width	3.00	4.00
Height	1.50 { 2.25 3.00	2.00 { 3.00 4.00

---

(1) Reservations by Austria and Poland

- 4.3.2.9 Additional Panels
- 4.3.2.9.1 Motorway signs may be supplemented with rectangular additional panels posted below the sign (RP).
- 4.3.2.9.2 The additional panels should consist of a white background with black characters, and have no border (RP).
- 4.3.2.9.3 The height of additional panels should be 0.50 m (RP).
- 4.3.2.9.4 The inscriptions on the additional panels should be 0.25 m in height (RP).
- 4.3.2.10 Location
- 4.3.2.10.1 Lateral motorway signs should be located on the right side of the carriageway in the direction of traffic or on both sides according to national legislation. The plane of the sign panel should be turned towards the oncoming traffic, forming an 80 - 85° angle with its direction (RP). They may also, however, be located above the carriageway (gantries).
- 4.3.2.10.2 Motorway signs must be located in such a way as not to obstruct traffic on the carriageway (S). For this reason, the edges of the signs must be placed beyond the safety fence or marker posts at a distance of no less than 1.80 m on the motorway itself and 1.00 m on the interchange slip roads.
- 4.3.2.10.3 The height of the lower edge of the sign should be no less than 1.20 m above the pavement (RP).
- 4.3.2.10.4 The heights for various signs of the same category should be kept equal (RP).
- 4.3.2.10.5 With regard to the signs on gantries and distance signs, reference is made to paragraphs 4.3.3.1.1 and 4.3.3.3.2 .
- 4.3.2.11 Variable Message Signs
- Variable message signs, activated automatically or by the motorway operation centre, must have the same characteristics (colours, shapes, symbols) as normal signs, and wherever possible symbols rather than words should be employed (S).

**4.3.3 Particular Cases**

4.3.3.1 Signing of Interchanges

Figures 4a and 4b show the recommended arrangement of the system of signs in the areas of motorway interchanges with an ordinary road and with another motorway (RP).

4.3.3.1.1 Gantries

Signs on gantries will be mounted above the carriageway to indicate to drivers the lane to be used in accordance with their destinations. The destination must be indicated above each lane, together with an arrow positioned above the centre of the lane (S). The signs should be rectangular in shape, and no less than 1.50 m in height (RP).

4.3.3.2 Place Identification Signs

4.3.3.2.1 Place identification signs should be used at the borders of two countries or between two regions of the same country, or to indicate the names of sites of special interest, such as rivers, tunnels, bridges, historical monuments, etc. (RP).

4.3.3.2.2 These signs should be of rectangular shape and of a size depending upon the length of the message and in conformity with the values given in paragraph 4.3.2.8 (RP).

4.3.3.3 Other Signs Providing Information to Drivers

4.3.3.3.1 Signs Notifying Beginning and End of Motorway

The beginning and end of motorway must be indicated by „Motorway Begins” and „End of Motorway” signs (S).

The „Motorway Begins” sign must be placed at the point where the special regulations for motorway traffic come into effect (S).

The „End of Motorway” sign must be placed at a distance of about 1,500 m ahead of the end of motorway (S), the distance being indicated on an additional panel posted below the main sign (S).

The „Motorway Begins” sign may be combined with a sign summarizing the basic prohibitions and rules governing motorway access (RP).

Both „Motorway Begins” and „End of Motorway” signs should be rectangular in shape, with a 1.70 m base and 3.00 m height (RP). They should have a green background, a white motorway symbol and the latter also an oblique red strip (RP).

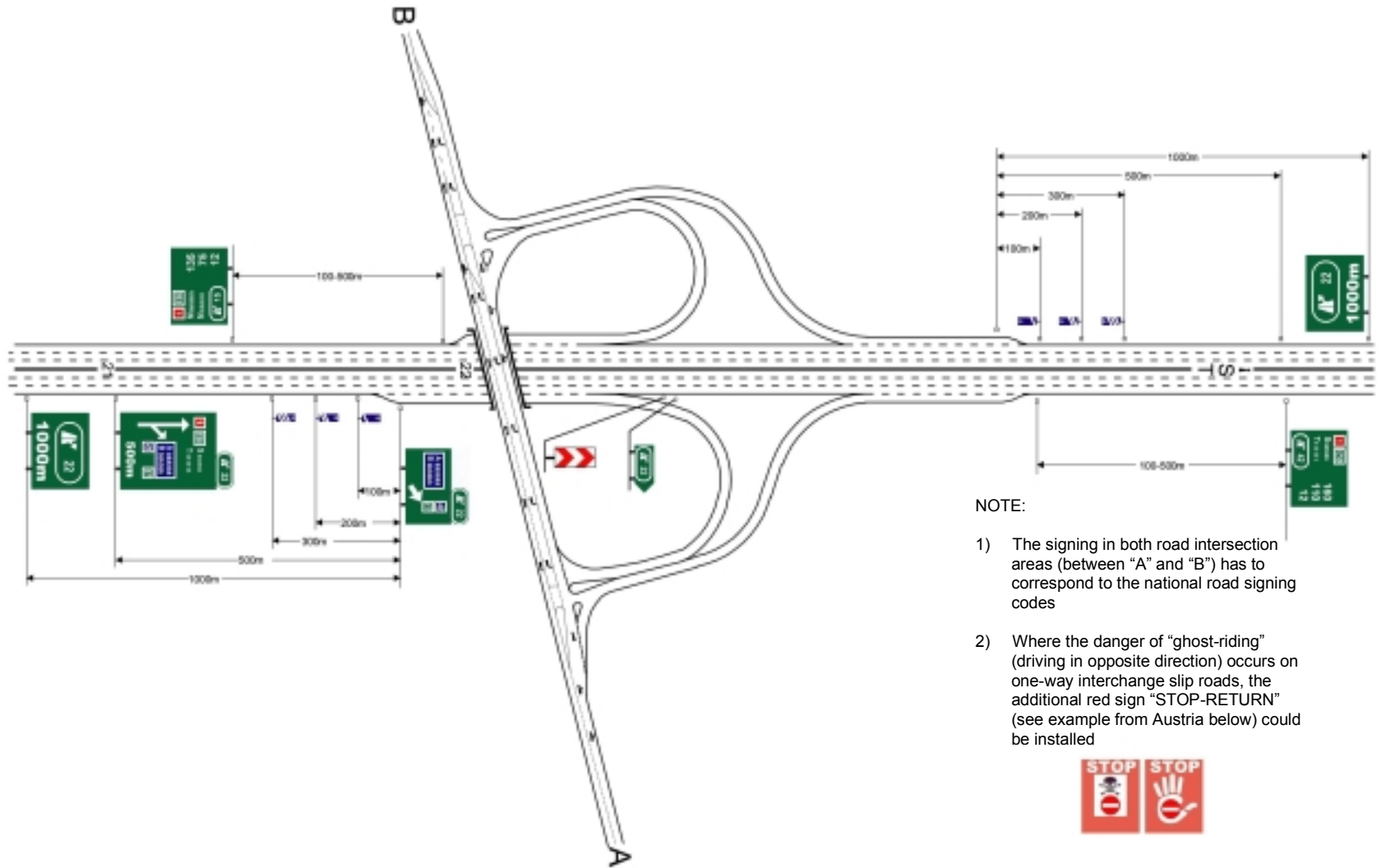
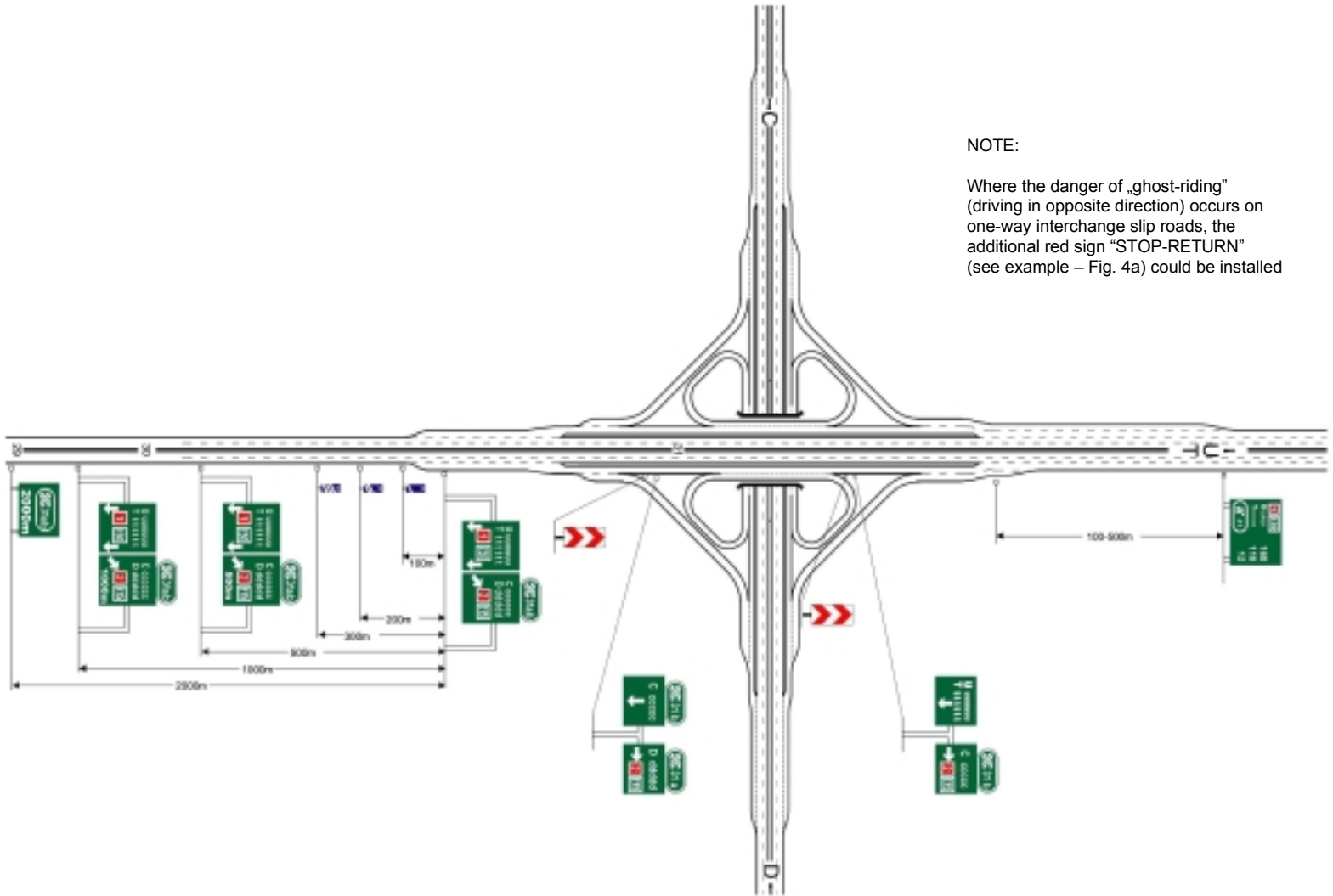

Fig. 4a - Signing of the motorway interchange with an ordinary road





NOTE:

Where the danger of „ghost-riding” (driving in opposite direction) occurs on one-way interchange slip roads, the additional red sign “STOP-RETURN” (see example – Fig. 4a) could be installed

Fig. 4b - Signing of the motorway interchange with another motorway

#### 4.3.3.3.2 Distance Signs

Signs indicating the progressive distance should be installed on the central reserve, in case of separated one-way carriageways, or on the right margin, in case of single two-way carriageway (RP).

These signs should furthermore indicate approaching interchange or service area and the appropriate distance (RP).

The part of the sign indicating the progressive mileage should have a white background with black characters (RP).

The part of the sign indicating the subsequent exit should have a green background with white characters (RP).

#### 4.3.3.3.3 Signs Indicating Works in Progress or Emergencies

In case of roadblocks, or any type of roadworks in progress which entail the closing of a carriageway or lane to traffic, it will be necessary to post portable signs to permit users to perform the necessary manoeuvres in safety (S). The signs should be reflective, and possibly be combined with flashing lights (RP).

The respective recommendations and examples of the arrangement of signs in such cases are contained in the document „Proposals for Harmonization of TEM Motorway Traffic Signing” of June 1995.

#### 4.3.3.3.4 Signs Indicating Additional Lanes

Figure 4c shows the recommended arrangement of signs at the beginning and at the end of the additional (climbing) lane.

#### 4.3.3.3.5 Signs Indicating Facilities

Service and rest areas must be preceded by advance signs, which may also be accompanied by symbols indicating the specific facilities offered by the area.

Figures 4d, 4e, 4f show the recommended arrangement of signs ahead of the rest area, service area and frontier check-point or toll plaza.

### 4.3.4 Illuminated Signs

4.3.4.1 Retroreflecting signs should be substituted with illuminated signs in all cases where, because of prevalent environmental conditions or location, they are not easily visible to users (RP).

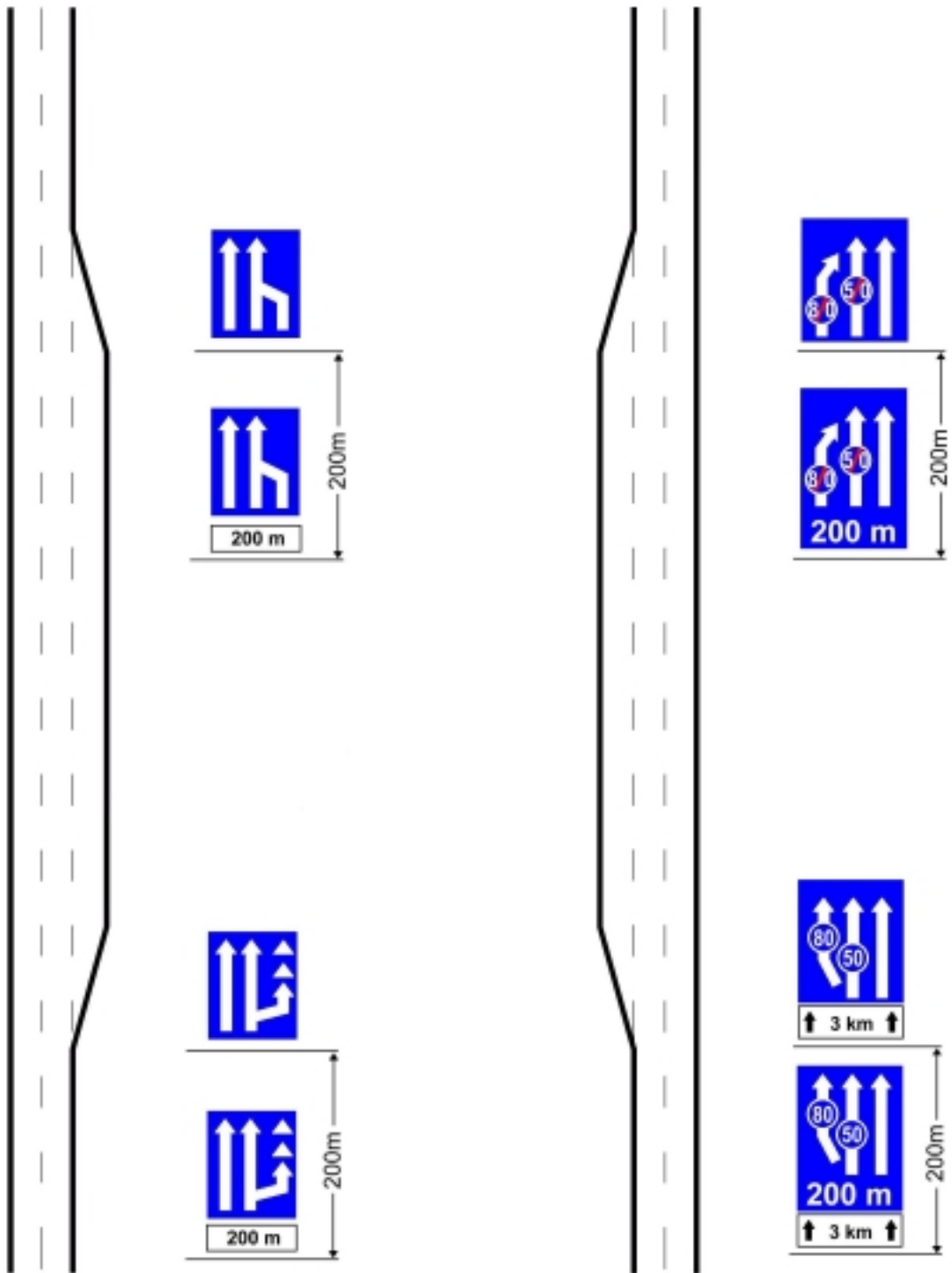

Fig. 4c - Signing of the additional lane

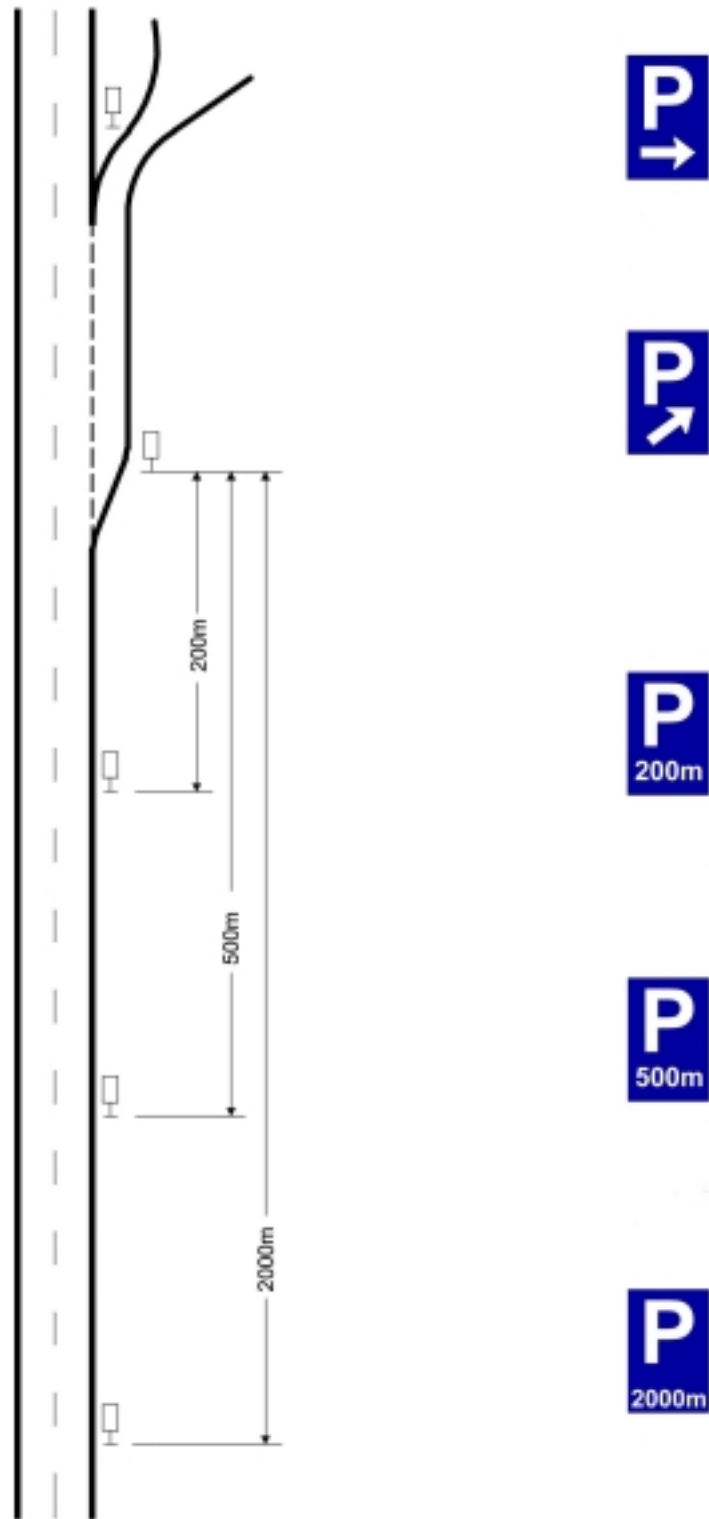

Fig. 4d - Arrangement of signs ahead of the rest area

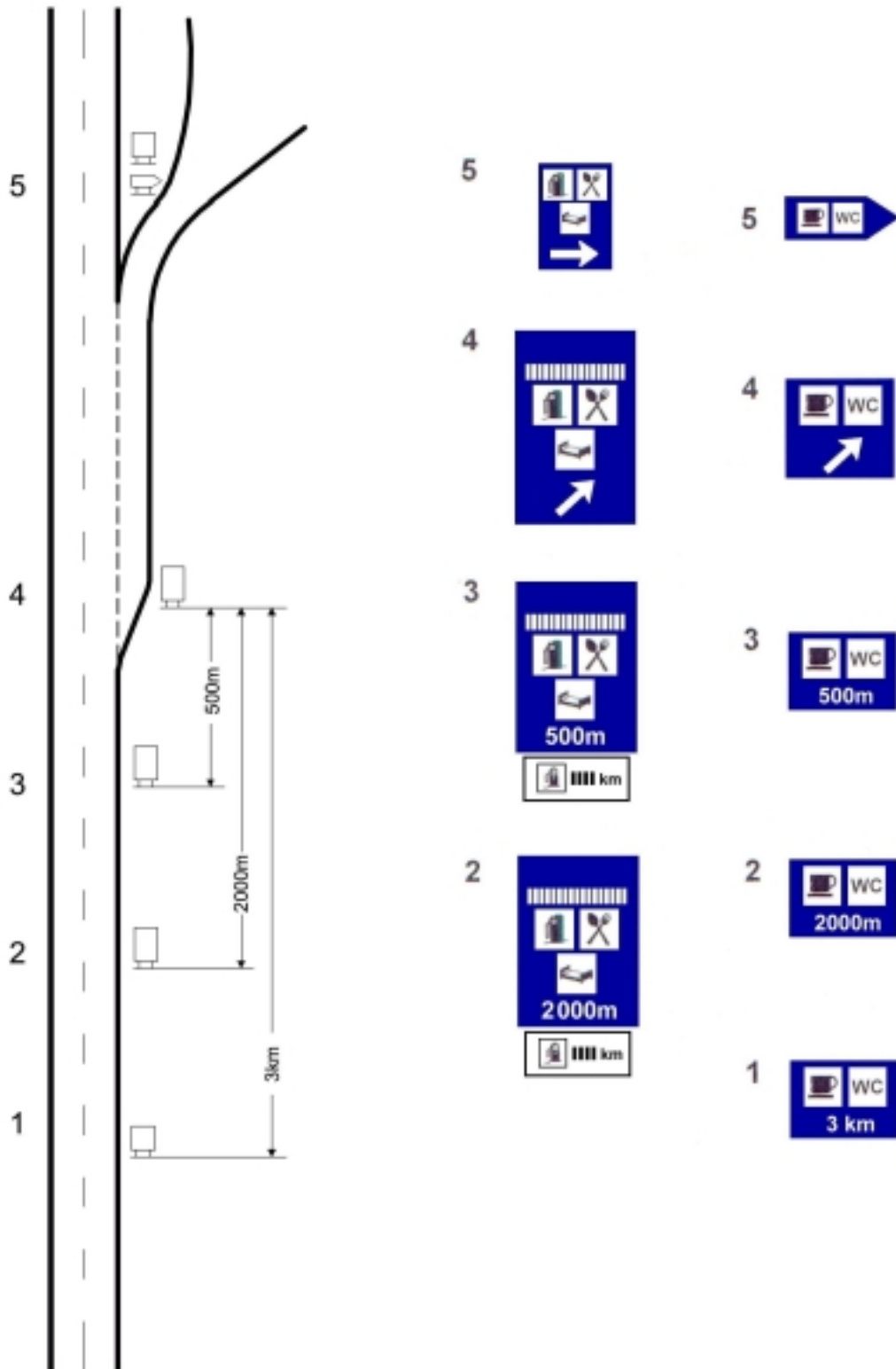
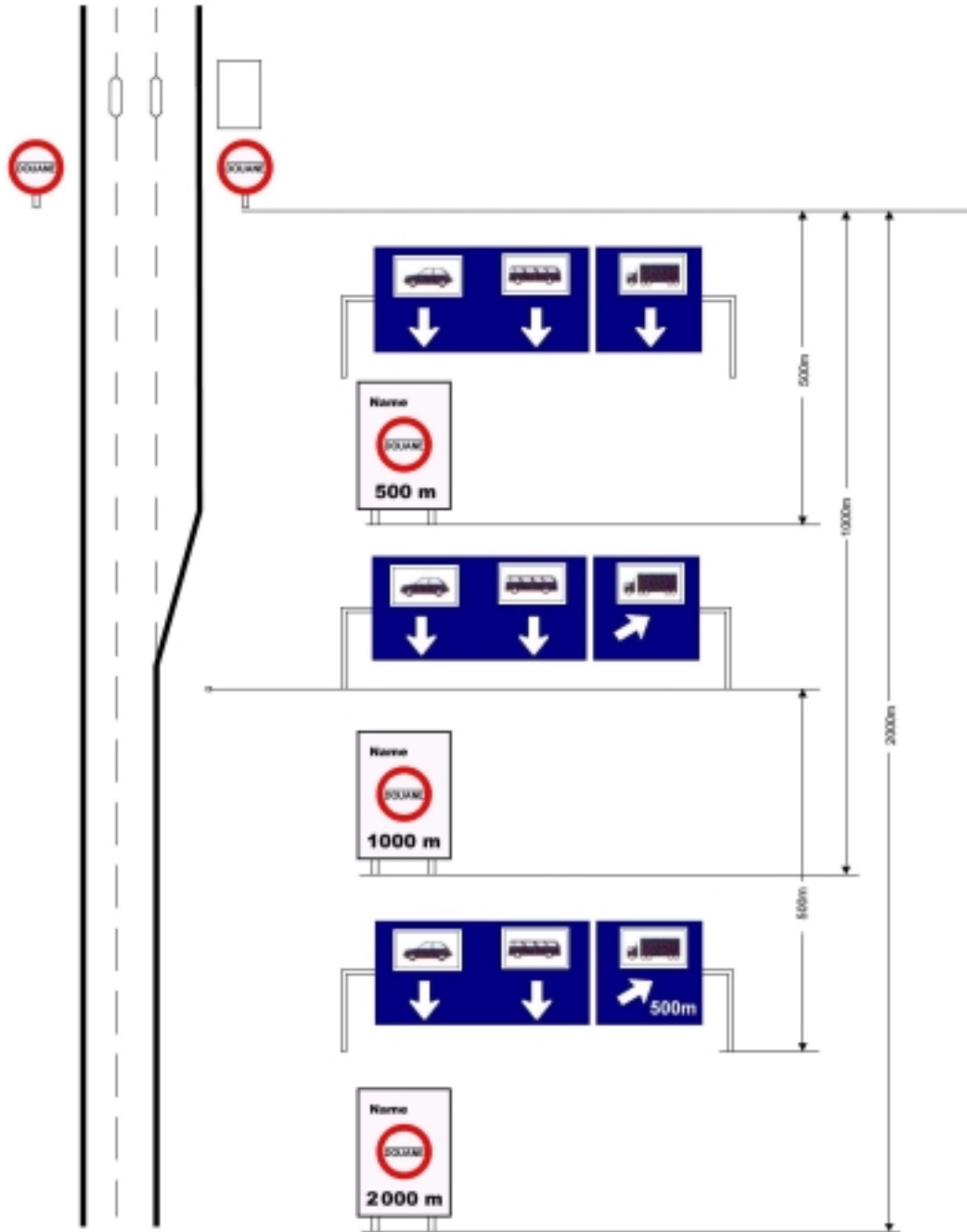

Fig. 4e – Arrangement of signs ahead of the service area



NOTES:

1. In the upper part of the circular sign the inscription "CUSTOM" in national language is located
2. Signing should be adjusted to local situation and could be further supplemented by an additional information below the car logo, e.g. "Nothing to declare", etc.
3. The same arrangement applies to toll plazas, whereas the inscription "CUSTOM" is replaced by "TOLL" in French (bottom) and national (top) languages

*Fig. 4f - Arrangement of signs ahead of the frontier check-point or toll plaza*

- 4.3.4.2 It is furthermore advisable to install illuminated signs in zones where large traffic flows merge or diverge and in toll plaza and border crossing approach zones (RP).
- 4.3.4.3 Illuminated signs may be of transparent or reflective type.
- 4.3.4.4 The electrical apparatus inside the transparent sign should provide uniform illumination by means of sufficiently powerful, low-heat lamps (RP).
- 4.3.4.5 Reflective illuminated signs shall consist of vertical signs as described earlier, lit by one or more lamps located in such a way as not to produce glare for motorway users (RP).
- 4.3.4.6 The reverse parts of these signs should be dim for the same purpose.

## **4.4 Marker Posts**

### **4.4.1 Scope**

- 4.4.1.1 Motorway carriageway and slip roads must be equipped with marker posts provided with reflectors (S).
- 4.4.1.2 Where there is a safety fence, reflectors may be affixed to it, as long as the normal height and spacing are maintained, thus eliminating the need to install marker posts (RP).

### **4.4.2 Sizes**

- 4.4.2.1 Marker posts should be vertical, 1.0 m in height above ground level, and must be properly installed so as to ensure their verticality (RP).
- 4.4.2.2 The cross section of the posts need not to be uniform, but the part facing traffic should have a visible width of at least 0.12 m (RP).

### **4.4.3 Colour**

Marker posts must be white in colour (S).

### **4.4.4 Material**

Marker posts must be lightweight, so as not to cause damage to vehicles if struck (S).

**4.4.5 Location**

Marker posts must be located along both sides of the carriageway on the limit of the shoulder (S).

**4.4.6 Reflective or Equivalent Devices**

Reflectors or equivalent devices must be installed on marker posts or safety barrier on both sides of the carriageway (S) in such a way for driver to distinguish between its left and right side.

**4.4.7 Spacing**

4.4.7.1 The distance between marker posts or reflectors should be no more than 50 m on the straight and on curves of a radius greater than 500 m (RP).

4.4.7.2 If the horizontal radius of the curve is less than 500 m, the spacing will depend upon the curvature radius according to the following table:

Table 4b

Horizontal Radius R (m)	Distance (m)
less than 150	0.1 R
151 – 200	15
201 – 300	20
301 – 400	30
401 – 500	40
more than 500	50

**4.5 Miscellaneous Safety Devices**

**4.5.1 Scope**

This section deals with the following fixtures:

- (a) motorway restraint systems (safety barriers and protective devices;
- (b) supports of predetermined breaking strength for traffic signs and for lighting systems.

**4.5.2 Safety Barriers**

4.5.2.1 Safety barriers are installed at the edges of the carriageways to prevent out-of-control vehicles from leaving the motorway in accordance with the accident risk assessment and based on location, traffic volume and traffic flow composition.



- 4.5.2.2 At low traffic levels, however, and where central reserves are sufficiently wide, provision of safety barriers may be unnecessary, since it might result in higher accident costs overall than if no barriers were present.
- 4.5.2.3 Also, in the case of the right-hand verge, certain combinations of embankment height and slope may render installation of safety barriers unsuitable (cf. paragraph 4.5.2.9).
- 4.5.2.4 Principle of Operation
- 4.5.2.4.1 Safety barriers should constitute, within certain limits, an insurmountable barrier, but at the same time be deformable to absorb impacts.
- 4.5.2.4.2 The elements comprising the safety barrier must be such as to react to collision as a system and not as isolated elements only.
- 4.5.2.5 Operation of Safety Barriers in Relation to Available Installation Space
- The need to provide for extensive deformation of the safety barrier will govern the choice of type, bearing in mind the available space and containment level.
- 4.5.2.6 Types of Safety Barriers
- 4.5.2.6.1 Safety barriers have to comply with the European Standard EN-1317 "Road Restraint Systems".
- 4.5.2.6.2 The following types can be considered:
- (a) steel safety barriers;
  - (b) concrete barriers;
  - (c) wire rope fences.
- 4.5.2.7 Safety Barriers on Central Reserve
- 4.5.2.7.1 Installation of safety barriers on central reserve is recommended in order to prevent out-of-control vehicles crossing into the opposite carriageway, with the consequent danger of head-on collisions (RP).
- In cases of narrow central reserve and/or high traffic volumes, the installation of safety barriers is necessary in accordance with national standards (S).

4.5.2.7.2 Treatment of Central Reserve Crossovers

To permit passage of emergency and surveillance vehicles and to divert traffic in cases where a carriageway must be closed for maintenance or other reasons, it is essential to provide suitably spaced crossovers in the central reserve (S).

These crossovers may be closed down, where appropriate, with removable barriers (RP). In cases where it is deemed inconvenient to install a removable barrier in the crossover, it is essential to adopt relevant measures to limit the hazards caused by breaks in continuity of the central reserve (S).

4.5.2.8 Protective Devices in Front of Fixed Obstacles (Crash Cushions)

Protective devices to absorb impact can be employed in particularly critical cases at the points where exit lanes branch off the motorway or in front of rigid obstacles. These devices have to comply with the European Standard EN-1317 “Road Restraint Systems – Part 3; Crash Cushions”.

4.5.2.9 Safety Barrier on the Right-Hand Verge of the Carriageway

Two diagrams are provided below as examples to determine the advisability of safety barrier installation, depending on the slope and the height of the embankment (see Figure 4g).

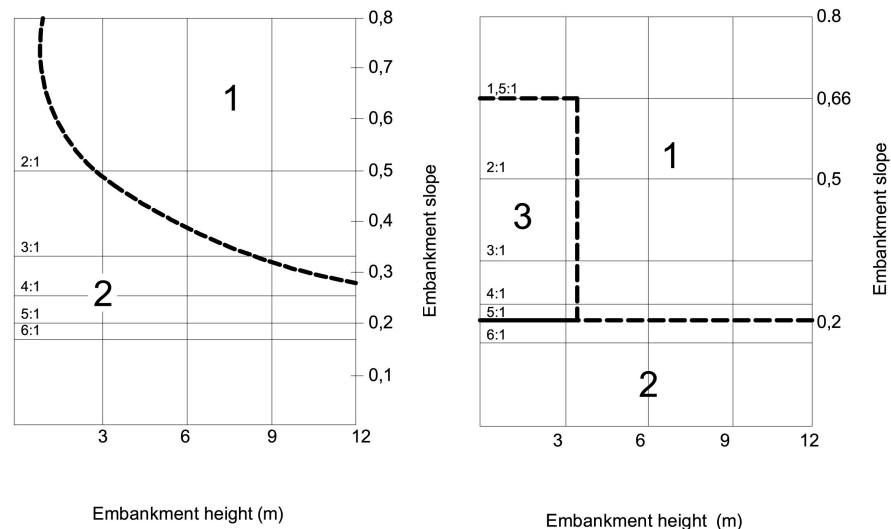

Fig. 4g - Diagrams based on experiments conducted in the USA and on Italian standards, providing criteria for safety barriers on the right-hand verge of carriageway, where:  
 1 - represents safety barrier required  
 2 - represents safety barrier not required  
 3 - represents zone of uncertainty

4.5.2.10 Protective Devices Around Fixed Obstacles

In addition, it is generally necessary to provide safety barriers around fixed obstacles such as vertical sign gantries, SOS call posts, deep gutters and bridge piers located along the edges of the pavement (RP).

4.5.2.11 Vertical Supports of Predetermined Breaking Strength

4.5.2.11.1 It is not necessary to install protective devices around road sign supports, light poles, etc., provided that the vertical elements of predetermined breaking strength are utilized (RP).

4.5.2.11.2 Supports have to comply with the European Standard ENV-12767 "Support Structures for Road Equipment – Requirements and Test Methods".

## 4.6 Emergency Call System

### 4.6.1 General Requirements

4.6.1.1 The proposed communication system must be suitable for transmitting information between pre-established points at regular intervals along the motorway and the operation centre, employing a two-way communication system (S).

4.6.1.2 It is necessary for the emergency assistance personnel to be able to communicate between the call posts and the operation centre in such a way as to be able to take the necessary emergency steps immediately (S).

4.6.1.3 The use of the equipment and its maintenance must be simple, and it should be easily understandable by the user.

### 4.6.2 Call Posts

4.6.2.1 Call posts must be located at roughly 2 km intervals along the motorway, and be connected also with the operation centre (S).

4.6.2.2 Communication between the call posts and the operation centre should be via radio or cable (RP).

4.6.2.3 Call posts should be provided with signal buttons for two-way communication. Each call post should have a minimum of two signal buttons, one with the symbol to be used when medical assistance is required, and the other with the symbol of the

mechanical service to be used in cases of vehicle breakdown (RP).

- 4.6.2.4 Call posts must be recognizable in shape, so as to attract the attention of the user (S).
- 4.6.2.5 The shape and dimensions of the call posts should be uniform along the whole length of the motorway (RP).
- 4.6.2.6 These call posts must be provided on the verge of both carriageways, opposite to each other, to deter users from attempting to cross the carriageway on foot (S).
- 4.6.2.7 Signal buttons and two-way communication apparatus should face the direction of traffic (RP).
- 4.6.2.8 There should be a light to illuminate the inside of the call post at night to identify the signal buttons; failing this, reflective equipment and lettering should be adopted (RP).
- 4.6.2.9 The points where the call posts are installed must be easily accessible and safe (S).
- 4.6.2.10 Installation of call posts on acceleration and deceleration lanes must be avoided (S).
- 4.6.2.11 Call posts should not be installed on bridges (RP).
- 4.6.2.12 In long tunnels, call posts must be installed on the right-hand side in relation to the direction of traffic, and therefore on both abutments, opposite each other, if the tunnel has two-way traffic. If the tunnel has one-way traffic, the posts shall be installed on a single abutment at the side of the slow lane.
- 4.6.2.13 In tunnels, call posts should be installed in lighted recesses and clearly indicated by lighted signs at a regular distance interval of maximum 150 m (RP).
- 4.6.2.14 No call post should be located in the initial section where the lighting known as reinforcement lighting serves as a transition between the outside lighting and that in the ordinary sections of the tunnel (RP).

### **4.6.3 Operation Centre**

- 4.6.3.1 Operation centre must operate 24 hours a day (S).
- 4.6.3.2 The centre must be able to (S):
  - (a) immediately identify the location of the car;

- (b) confirm reception in cases of calls via the signal button;
- (c) perform the operations needed to dispatch the necessary assistance.

4.6.3.3 The operation centre must be directly connected with the relevant (S):

- ambulance station;
- fire station;
- police station;
- peripheral maintenance centres;
- mechanical assistance station;
- public telephone network.

4.6.3.4 There must be a radio communication system connecting all police and emergency service patrol vehicles and the operation centre (S).

## **4.7 Antiglare Devices**

4.7.1 It is advisable to install antiglare devices along the whole length of the motorway (RP).

4.7.2 When the advantages are insufficient to balance the costs, or there are particular installation or maintenance difficulties, it will be convenient to install the devices on limited sections only (e.g. where the traffic exceeds certain limits and where the width of the central reserve and the layout of the route so require) and in cases covered by the standards in force in the respective country.

4.7.3 Where it is advisable to install an antiglare device on the central reserve, this should preferably consist of a hedge or of an artificial screen (RP).

## **4.8 Precautions Concerning Animals**

### **4.8.1 Scope**

4.8.1.1 General observations regarding the relationship between the road and the environment are set out in Chapter 6.

4.8.1.2 The following paragraphs provide suggestions for avoiding or at least limiting the danger of animals crossing the motorway and for protecting the local fauna from the intrusion of the motorway.

#### **4.8.2 Measures for Protection from Animals**

4.8.2.1 Domesticated or wild animals shall be denied access to the motorway (S).

4.8.2.2 It may be necessary to install fencing along the whole length of the motorway, or at least on those sections where special environmental studies indicate a high probability of animals crossing the motorway (RP).

4.8.2.3 The fencing, consisting usually of a tight metal mesh, should be installed at the edges of the motorway property.

4.8.2.4 The fence height should vary from a minimum of 1.50 m to a maximum of 2.50 m on sections characterized by heavy snowfalls and greater numbers of animals (RP).

#### **4.8.3 Overpasses and Underpasses for Wild Animals**

Where the motorway crosses the zones of big wild animal populations, suitably sized and shaped overpasses and underpasses for animals must be constructed (S). The effectiveness of the safeguard measures thus adopted should be verified from time to time by checking the state of animal populations of the zone (RP).

### **4.9 Traffic Control and Provisions for Traffic Diversion**

#### **4.9.1 General**

4.9.1.1 On certain motorway sections (near important urban or tourism centres, in mountain zones, in frontier or custom areas, at toll stations, etc.) and at certain times of the year, situations may arise involving high traffic volumes and/or lowered capacities, with resulting poor safety and service levels. As an alternative to expensive roadworks to increase the motorway capacity, or in expectation of such works, it is in such situations desirable to install reliable information systems which will permit the user to regulate his speed and to select the better route, and permit the competent bodies to take timely measures to ensure better traffic safety and service levels.

4.9.1.2 For the above reasons as well as for data transmission, telephone communication and future implementation of intelligent transport systems, etc., it is desirable to provide, at the construction stage, for the installation of ducts along the whole length of the motorway for the passage of cables, conduits, etc. (RP).

**4.9.2 Information for Users**

4.9.2.1 It is desirable that the competent authorities of each country employ the national information media to give users the information necessary to make the most suitable choices.

4.9.2.2 In particular, the information should be provided on (RP):

- (a) days and hours of heaviest traffic and congestions;
- (b) weather and road conditions;
- (c) roadworks and closures;
- (d) possible alternative routes;
- (e) waiting times at border crossings;
- (f) accidents.

4.9.2.3 It is also desirable to install systems providing motorway users with quick local information (within 15 minutes) besides that provided by the traditional fixed sign system (RP).

4.9.2.4 At present, two main techniques fulfil this task:

- (a) remote control variable-message signs;
- (b) information systems within vehicles themselves.

4.9.2.4.1 Remote Control Variable-Message System

This system is a reliable and effective technique to provide for optimum distribution of traffic along the motorway and to correct users' behaviour.

There are various types of sign panels, e.g.:

- (a) rotating prism panels;
- (b) lamp panels;
- (c) optical fibre panels.

Depending on needs and the local situation, the competent authorities should select the most appropriate type and suitable locations of the panels (RP).

4.9.2.4.2 Information Systems within Vehicles

The information supplied within vehicle may be communicated either as sound messages received by the vehicle radio or other receivers, or via optical signals received inside the vehicle by means of special receivers.

- (a) regarding sound information, there are several systems which utilize transmitters employing different frequencies depending upon the zone, and receivers consisting of normal radio

devices, possibly with slight modifications; in this case it is necessary to post signs along the motorway to inform drivers of the transmission frequencies, with the messages being preceded by a special identification signal;

- (b) in the field of optical information, experiments are being undertaken with various systems providing the user with specific information on the road and traffic conditions on the specific route he should use and his position.

In both cases, the information should be supplied to the user by the competent organisation responsible for the particular motorway section (RP).

### **4.9.3 Information for Management Agencies**

4.9.3.1 For effective control of motorway traffic it is advisable that the competent management organization receives information on traffic and road conditions via suitable automatic monitoring systems (RP).

4.9.3.2 In particular, the operation centre of this organization should receive information regarding the following:

- (a) road accidents;
- (b) obstacles on carriageways;
- (c) poor weather conditions;
- (d) traffic situation;
- (e) border crossing situation.

4.9.3.3 Besides the emergency call system (cf. Section 4.6), the adoption of automatic monitoring systems is recommended (RP). Data thus obtained should be transferred to the operation centre.

### **4.9.4 Regulatory Measures in Congested Situations, during Roadworks or after Accidents**

4.9.4.1 Once in possession of all the necessary information, the operation centre shall take the necessary steps in timely fashion.

4.9.4.2 In general, there are three methods of regulation the traffic in situations of congestion, during carriageway repairs or in cases of serious accidents:

- (a) regulation by network;
- (b) regulation at entry slip roads;
- (c) linear regulation.

4.9.4.3 Particular attention should be paid to the custom zones, where automatic traffic counters may be installed directly connected to



the competent bodies/authorities In such cases, variable message panels should be installed for the information of users.

4.9.4.4 Regulation by Network

4.9.4.4.1 This method diverts certain traffic flows towards diversion routes. A diversion route should have a travel time less or equal to that of the congested section of the motorway (RP).

4.9.4.4.2 In all cases, it is necessary to know the road and traffic conditions on this route (S).

4.9.4.4.3 To inform users of possible detours, use should be made of portable emergency signs posted by the maintenance units in the manner described in paragraph 4.9.6 or, if such exists, the information systems described in paragraph 4.9.2 (RP).

4.9.4.4.4 It is absolutely necessary that there be collaboration between the maintenance unit personnel and the motorway/highway police (S).

4.9.4.5 Regulation at Entry Slip Roads

4.9.4.5.1 The basic aim of this type of regulation is to ease congestion and improve traffic flow on the motorway by limiting the number of vehicles entering at the entry slip roads according to the traffic density on the motorway.

4.9.4.5.2 This method assumes capacity measurements are taken on the section of motorway in question (RP).

4.9.4.6 Linear Regulation

4.9.4.6.1 This type of regulation, performed with the aid of variable message signs and possibly portable emergency signs, is aimed at regulating the utilization of lanes and speeds so as to obtain optimum safety and service levels on the motorway section involved.

4.9.4.6.2 Linear regulation systems include the following:

- (a) regulation of speeds to ensure an optimum speed depending on the existing circulation conditions;
- (b) regulation by lane to ensure optimum distribution of traffic on the different motorway lanes;
- (c) regulation of confluences of two traffic flows to ensure good traffic conditions at the points of confluence.

**4.9.5 General Monitoring of Traffic Data**

4.9.5.1 It is advisable to install all along the length of the motorway a number of fixed points to monitor the hourly traffic volumes and

composition; each individual section should have at least one such point (RP).

4.9.5.2 An individual section is understood to mean a section between two interchanges along which the AADT and the hourly distribution of traffic do not change substantially.

4.9.5.3 The breakdown into individual sections should be made on the basis of traffic surveys carried out over the first five years of motorway operation, and rechecked at least every five years, or else in conjunction with general traffic censuses in each country (RP).

4.9.5.4 In case of the sections characterized by high service levels (higher than D) for a great number of hours per year, it is also advisable to install a fixed point to monitor speeds (RP).

#### **4.9.6 Installation of Portable Emergency Traffic Signs**

4.9.6.1 The general criteria for the installation of portable emergency signs are that these shall:

- (a) provide the user with a supply of information which is neither excessive nor insufficient (RP);
- (b) increase as much as possible the length of the pre-signal zone so as to provide the information in time for the user to perform the required manoeuvres in safety (RP);
- (c) allow, in cases where the section to be closed to traffic consists of a number of lanes, the closure of one lane at a time in suitably spaced fashion (RP); this will serve to stagger the points of merging;
- (d) graduate speed variations so as to avoid causing unstable flow conditions (RP);
- (e) respect the conditions set out in paragraph 4.3.3.3.3 (S).

4.9.6.2 Portable signs should be suitably heavy to prevent shifting or toppling by winds.

4.9.6.3 The signs must be installed in such a way as not to endanger traffic (S).

4.9.6.4 In case of double one-way carriageways, the signs should be located on the left side as well (RP).

4.9.6.5 The sections closed to traffic shall be marked over their whole length by marker posts located at regular distances; at night and in limited visibility conditions, flashing lights or lanterns must be provided (S).

## **4.10 Light Signals and Motorway Lighting**

### **4.10.1 Scope**

4.10.1.1 Experience shows that a large percentage of road accidents, especially serious ones, occur at night or under poor visibility conditions in general.

4.10.1.2 In order to reduce risks in such situations, it is thus advisable to light certain motorway sections and to install light signals where these are deemed necessary.

### **4.10.2 Light Signals**

#### **4.10.2.1 Flashing Yellow Lights**

These should be employed at the entrance to station bumpers at toll stations or as a temporary solution in cases of accidents or roadworks to signal reduced speed or traffic deviations when maintenance works are underway, as well as to alert drivers' attention to possible danger signals (RP).

#### **4.10.2.2 Traffic Signals**

No traffic signals are installed on the motorway proper, as all intersections must be grade-separated, but they may be used in tunnels, toll stations and frontier check-points as well as temporarily in emergency situations (roadworks, accidents, etc.).

### **4.10.3 Road Lighting**

#### **4.10.3.1 Scope**

A road lighting system should ensure a sufficient contrast of luminance between the obstacle and the background against which the obstacle is projected.

4.10.3.2 Lighting must be provided at the following points (S):

- (a) service areas;
- (b) toll station plazas;
- (c) in the vicinity of brightly lit urban zones;
- (d) border crossing areas.

4.10.3.3 Lighting should be provided on interchanges and by means of special devices, can be effective also in zones of frequent fog (RP).

4.10.3.4 For illumination in tunnels, see Chapter 8.

4.10.3.5 General Characteristics

In designing road lighting systems, once the average level of luminance to be provided is established, the following main factors must be examined:

- (a) reflecting properties of the pavement;
- (b) position of the light sources;
- (c) types of lighting sources and supports.

4.10.3.6 Position of Light Sources

4.10.3.6.1 The possibility of combining the various luminance cones of the different light sources into a single lighted strip depends mainly on the positioning of these sources. Suggested arrangements of light sources are as follows (RP):

- (a) unilateral arrangement, i.e., with light sources installed on one side of the carriageway only;
- (b) alternating lateral arrangement, i.e., with light sources installed alternately on both sides of the carriageway;
- (c) symmetrical arrangement, i.e., bilateral with sources opposite one another.

4.10.3.6.2 The installation of light sources on central reserve is inadvisable insofar as maintenance is difficult and dangerous, particularly in the presence of high traffic volumes.

4.10.3.6.3 It is suggested that the installation height be equivalent to the width of the carriageway in case of unilateral arrangements, and no less than half this width in case of alternating lateral or symmetrical arrangements (RP).

## **5 FACILITIES**

### **5.1 Types**

5.1.1 Depending on their functional characteristics, motorway facilities can be grouped in the following types:

- (a) rest areas;
- (b) service areas;
- (c) toll facilities;
- (d) frontier check-points.

5.1.2 Facilities shall be accessible from the motorway only.

5.1.3 Pedestrian access may be provided from the ordinary road network for use by tradesmen and service personnel (RP).

5.1.4 Facilities must be accessible to disabled persons in accordance with the respective national standards (S).

### **5.2 Rest Areas**

5.2.1 Rest areas are separated physically from the motorway carriageways and provide the user with an opportunity to halt in an atmosphere which affords a distinct change from motorway driving.

5.2.2 Each rest area must be provided with acceleration and deceleration lanes (S), road signs and markings (S).

5.2.3 Water supply , sanitary facilities and waste water drainage should also be provided (RP).

5.2.4 Dimensions and arrangement of rest areas must be designed in accordance with their expected usage (S).

### **5.3 Service Areas**

5.3.1 Service areas should provide fuel, lubricants and mechanical assistance, rest, refreshment and toilet facilities, and overnight motel accommodation for users, plus shops and tourist services.

5.3.2 The combination of services offered will depend on the overall plan for the relevant section of the motorway.

5.3.3 The main combinations could be as follows:

- (a) fuel station + coffee shop;
- (b) fuel station + restaurant + workshop;
- (c) fuel station + restaurant + motel + workshop.

5.3.4 In addition to the usual parking areas, each service area must be provided with the following (S):

- (a) acceleration and deceleration lanes;
- (b) electrical power and drinking water systems;
- (c) waste water and sewage disposal system;
- (d) outside lighting system;
- (e) telephone;
- (f) road markings and signs.

## **5.4 Spacing Criteria of Rest and Service Areas**

### **5.4.1 Distance from Interchanges**

In order to ensure safety and comfort of motorway users, service areas should be located at a distance of no less than 3.0 km from interchanges (RP). In cases where this rule cannot be observed, the distance may be reduced or a service area may be situated in the vicinity of the interchange using the same entrance and exit slip roads.

### **5.4.2 Distance between Rest Areas**

The distance between rest areas should be 15 to 25 km (RP).

### **5.4.3 Distance between Service Areas**

5.4.3.1 The distance between service areas should be from 30 to 50 km (RP).

5.4.3.2 The distance to the subsequent service area has to be posted prior to the preceding one (S).

## **5.5 Location of Rest and Service Areas**

Apart from the distribution described in Section 5.4, it is necessary to take into account main factors influencing the choice of the site where the installation is to be built.

### **5.5.1 Topography of Terrain**

5.5.1.1 An irregular topography can prove itself favourable for the location of a rest area; the possibility of laying out the paved areas in various ways, following the terrain forms, permits the creation of a facility particularly suited for a rest break, far from motorway traffic.

5.5.1.2 For service areas, on the other hand, this criterion should not be applicable, insofar as both the size of civil engineering works and of the areas to be paved necessitate the choice of sites which are practically flat so as to reduce the necessary earthworks to a minimum (RP).

### **5.5.2 Horizontal and Vertical Alignment of Motorway**

5.5.2.1 The necessary sight distance for stopping must always be guaranteed, especially in the vicinity of motorway entry and exit points (S). The facilities should not be located immediately after a hog vertical curve of minimum radius, nor in the proximity of a minimum radius horizontal curve (RP).

5.5.2.2 As far as possible, one should also avoid locations on motorway stretches with gradients exceeding 4% (RP).

### **5.5.3 Degree of Urbanisation at Sites**

It is important to examine this factor, especially with respect to the location of service areas. In fact, it is advisable for economic reasons to locate the latter in the immediate vicinity of telephone, electrical power and ordinary road networks and, where possible, near water and sewerage networks; connections with the latter are always preferable to having to construct independent systems.

### **5.5.4 Scenic and Historic Values**

5.5.4.1 The attraction of the service facility also depends upon the presence of scenic and historical points of interest.

5.5.4.2 Other things being equal, therefore, preference is to be given to places affording scenic views or located near historical sites or sites of natural value. In these cases, the facilities should be designed so as to avoid marring the landscape, but at the same time permit the user to enjoy the attractions of the site (RP).

## **5.6 Design Criteria of Rest and Service Areas**

### **5.6.1 General**

In designing any given area it is necessary to take into account the following constraints:

- (a) distribution of facilities along the motorway;
- (b) site selected;
- (c) stage construction, if applicable.

### **5.6.2 Capacity of Facilities**

5.6.2.1 The number of facility users, and hence the size of the area, depend upon:

- (a) Traffic volume (AADT - annual average daily traffic, type and fluctuations);
- (b) composition of the traffic;
- (c) types of service offered;
- (d) distance from other similar services;
- (e) potential ability of the management to render the stop a pleasant one.

5.6.2.2 Since it is difficult to provide capacity criteria for these facilities along the whole length of the TEM, the minimum dimensions given in the national standards or regulations should be followed (RP).

### **5.6.3 Acceleration and Deceleration Lanes**

Both rest areas and service areas must be equipped with acceleration and deceleration lanes according to the standards prescribed in paragraphs 3.4.2 and 3.4.3.

### **5.6.4 Internal Circulation and Distribution of Sites Equipped for Parking**

5.6.4.1 The following standards should be followed in the design of these facilities:

- (a) circulation should be in the same direction as that of the carriageway to which the area is connected (RP);
- (b) normally, the roads and parts reserved for passenger cars, separated from those for heavy vehicles, should be located in the service area zone in such a way that the facilities can be seen (RP); the zone reserved for heavy vehicles, on the other hand, should be located at the rear of the area (RP). This principle may be reversed in case of rest areas, where



ordinarily the zone farthest from the motorway is the most suitable for passenger cars (RP);

- 5.6.4.2 Parking spaces in the service area should be located in the immediate vicinity of the refreshment facilities; this reduces walking distance to a minimum and permits leaving the vehicle unattended (RP).
- 5.6.4.3 Further parking for stops not connected with the use of service facilities can be provided in zones surrounding the area, and set up in accordance with the same criteria adopted for the rest areas (RP).
- 5.6.4.4 Parking places for buses should be located near the refreshment facilities and set up in such a way as to ensure sufficient safety for passengers (possibly surrounded by green zones) (RP).
- 5.6.4.5 Access roads to the area and internal circulation roads shall be one-way, and have a cross section no less than 6 m in width, including the edge markings and shoulders (S) (cf. Figure 3e-a).
- 5.6.4.6 All the zones, both for traffic and for stopping, should be separated from the motorway by a buffer zone no less than 10 m in width or, in exceptional cases, 7.50 m. This zone should be planted with vegetation (grass and bushes of limited height) (RP).
- 5.6.4.7 Internal roads of both service areas and rest areas should be planned in such a way as to avoid creating points of conflict.
- 5.6.4.8 If necessary, facilities can be connected with the ordinary road system by means of a road no less than 5.00 m wide provide that the access of general public is prevented (RP).
- 5.6.4.9 It is advisable that the zones used for the facilities themselves, for parking and for the circulation of vehicles be separated from each other by green zones according to the criteria set out in paragraph 5.6.8 (RP).

## **5.6.5 Electrical Systems**

- 5.6.5.1 The design of electrical systems must take into account the needs of the area in its final stage (S).
- 5.6.5.2 These systems will be installed according to the standards in force in the individual countries (S).
- 5.6.5.3 Acceleration and deceleration lanes, junctions of the internal road system, fuel stations and parking lots have to be lit in order to ensure maximum safety for traffic movement (S).

5.6.5.4 Care must be taken to avoid dazzling drivers on the motorway (S).

## **5.6.6 Road Markings and Signs and Safety**

Besides the warning signs along the motorway (dealt with in Chapter 4), both rest areas and service areas should be equipped with road markings and signs for the following purposes:

- (a) to limit speeds to 40 km/h (RP);
- (b) to give advance warning of junctions (S);
- (c) to prevent stopping outside the zones specifically designated for parking (S);
- (d) to advertise the various services offered by the area (RP).

## **5.6.7 Water Supply and Sanitary Systems**

5.6.7.1 Service areas should be provided with a water system both for drinking, preferably connected with public networks and for industrial purposes (washing, irrigation, WC) (S). A water system should also be provided for rest areas (RP).

5.6.7.2 In order to save on drinking water, it is advisable to provide an independent water distribution system for industrial use, fed by an independent supply system (well, supply from watercourses, lakes, etc.) (RP).

5.6.7.3 In cases where the entire water supply must be obtained from an independent system, it would still be advisable to construct two separate distribution networks so that it would only be necessary to purify the water used strictly for drinking purposes (RP).

5.6.7.4 Rest areas and service areas must be equipped with drainage for the disposal of rain and waste water (S), connected with the motorway drainage system; where it is impossible to arrange a connection with the public sewerage network, foul water will have to be treated (S).

## **5.6.8 Landscaping**

5.6.8.1 Vegetation should be characteristic of the local terrain (RP). Refreshment and assistance facilities, fuel stations and parking lots should be separated by green zones (RP). Parking lots should be arranged in such a way as to be shaded by trees or high shubbery (RP). The whole zone separating the area from the motorway carriageway should be planted with greenery, preferably with plants which require little maintenance, but whose density constitutes protection against vehicles possibly running off the road and prevents pedestrians from attempting to cross the carriageway (RP).

5.6.8.2 In the vicinity of the nose of the entrance or the exit, plants must be of limited height so as not to interfere with driver's vision (S).

## **5.6.9 Pedestrian Crossings**

5.6.9.1 Wherever it is considered useful to provide passage for service personnel or users who wish to take advantage of services available in the areas on the opposite side of the motorway, this can be provided by means of walkways passing either over or under the carriageways (RP).

5.6.9.2 It is then advisable to install a fence on the central reserve to prevent pedestrians from crossing motorway carriageways (RP).

5.6.9.3 In case of underpasses, suitable lighting and drainage systems must be provided (S).

## **5.7 Buildings and Equipment**

### **5.7.1 Promotional Centres**

5.7.1.1 Service areas located in areas of particular interest due to the types of activity which are carried out there, and which have adequate space and sufficiently high motorway traffic levels, could be provided with promotional centres.

5.7.1.2 An office should also be provided which can supply all necessary information (RP).

### **5.7.2 Sanitary Facilities**

5.7.2.1 It is advisable that the sanitary facilities be constructed for specific uses according to varying criteria, depending on their location within the area (RP).

5.7.2.2 In all cases it will be advisable to provide for non-removable sanitary fixtures with embedded controls, easily cleaned, with larger than normal outlets and easily inspectable, with automatic time-control taps, with floors designed for easy washing with jets of water or steam, and with discharge direct into the sewerage network (RP).

5.7.2.3 Where these are located within buildings (service station, restaurant, coffee shop), they may be equipped with mirrors, electric hand dryers, soap dispensers, electrical outlets, paper dispensers, a cabinet for cleaning and maintenance materials, and a small room for the maintenance staff (RP).

- 5.7.2.4 It would also be useful to equip a small room for the needs of young children, with miniature facilities, a table for changing babies, automatic babies' nappy dispensers, food-warmer, etc. (RP).
- 5.7.2.5 In the service areas specially equipped for servicing heavy vehicles, the sanitary facilities should be located in premises near the parking areas and have more practical features, i.e., sinks of larger dimensions, showers, changing rooms, etc. (RP).
- 5.7.2.6 In rest areas, where the sanitary facilities will almost always be unsupervised, it will be necessary to adopt equipment of very simple construction, designed in such a way as to prevent vandalism; greater care should be taken in the construction of outlets, so as to eliminate as far as possible any danger of clogging (RP).

## **5.8 Toll Facilities**

### **5.8.1 Scope**

- 5.8.1.1 If it is planned to charge a toll, the motorway should be equipped with suitable collection facilities.
- 5.8.1.2 The number and types of facilities and buildings will vary depending on the collection system adopted.
- 5.8.1.3 The main parameters distinguishing various types of toll collection systems are the station location and the collection method.
- 5.8.1.4 For location purposes, three different situations may be envisaged:
- (a) collection points located at all interchanges with the ordinary road system (closed system); in this case, the toll will be proportional to the actual length of the trip;
  - (b) toll collection at a limited number of suitably selected points along the motorway (open system); in this case, the toll is based not on the distance actually travelled but on a suitably calculated average distance;
  - (c) collection at frontier posts; here the stations are located only at the borders and the toll is calculated as a lump sum.
- 5.8.1.5 The toll collection method will also depend upon the classification system adopted for vehicle handling (manual/automatic) and the payment system (cash, current account, pass, prepaid ticket, etc.).

**5.8.2 General Criteria**

- 5.8.2.1 Once the toll collection method is chosen, the toll stations will have to be designed according to (S):
- (a) number and dimensions of the toll station lanes;
  - (b) dimensions of the toll station plaza;
  - (c) dimensions of the buildings and auxiliary structures;
  - (d) toll collection system.
- 5.8.2.2 Toll Station Lanes
- 5.8.2.2.1 The number of toll lanes per station shall be determined depending on the maximum number of queuing vehicles calculated on the basis of traffic forecast (S).
- 5.8.2.2.2 Specifically, the traffic figures to be used as the basis for the calculation should be the volumes at the 50<sup>th</sup> peak hour between the 5<sup>th</sup> and 10<sup>th</sup> year of operation (cf. paragraph 2.1.2) (RP).
- 5.8.2.2.3 The number of toll lanes should be sufficient to handle the above traffic volume with queuing lanes not exceeding 500 m in length, taking into account the average times needed for toll collection (exit traffic) and vehicle classification (entry traffic) (RP).
- 5.8.2.2.4 It is advisable to provide special lanes for freight traffic (RP).
- 5.8.2.2.5 At stations handling large volumes of traffic, it is desirable to provide the possibility of using a certain number of central toll lanes in either direction, so as to cope with cyclical traffic fluctuations and reduce construction costs (RP).
- 5.8.2.2.6 All stations have to be provided with at least one lane of larger size, reserved for oversize vehicles and snow removal equipment (S).
- 5.8.2.2.7 Toll lanes should be 3.00 to 3.50 m in width (RP).
- 5.8.2.2.8 Where such lanes are planned, automatic vehicle counting devices should be installed (RP).
- 5.8.2.2.9 The lanes should furthermore be separated from one another by an island about 2.00 m in width and about 30.00 m long (RP).
- 5.8.2.2.10 This island shall contain:
- (a) booths for the toll collection staff (S);
  - (b) safety fences for the protection of the booths and the staff (S);
  - (c) lifting barriers to close the lanes (S);

- (d) equipment connected with the toll collection system (automatic ticket dispenser, toll display panel, devices for automatic vehicle classification, etc.) (RP).
- 5.8.2.2.11 Toll station should be protected by an overhang roof with a height clearance of at least 5.00 m (RP).
- 5.8.2.2.12 Traffic lights shall be installed on the roof above each toll lane to indicate whether the lane is in operation (S).
- 5.8.2.2.13 Toll booths shall be designed so as to provide the toll collection staff with suitable working conditions (S). In particular, these booths should be air-conditioned, soundproof and equipped with a phone connection with the coordination centre (RP).
- 5.8.2.2.14 It is advisable to locate the toll stations in well-ventilated places so as to avoid the concentration of exhaust fumes (RP).
- 5.8.2.2.15 A passage of at least 2.00 x 2.00 m should be provided beneath the toll station for the laying of a system supply cables, heating pipes, etc. (RP).
- 5.8.2.2.16 At larger stations it is advisable to construct a passage of sufficient size to allow toll collectors to walk to and from their boots in safety (RP).
- 5.8.2.3 Toll Plaza
  - 5.8.2.3.1 Toll plaza of the toll station consists of a widening of the motorway carriageway (open system) or of the interchange slip roads (closed system) needed to contain the waiting traffic.
  - 5.8.2.3.2 The length of the toll plaza should be at least equal to that of the queues forecast (RP).
  - 5.8.2.3.3 Furthermore, an approach section should be provided of variable width and of sufficient length to permit safe channelling of the traffic and full use of all toll lanes (RP).
  - 5.8.2.3.4 For reasons of safety it is inadvisable to locate the toll plaza at the end of a long downhill section (RP).
  - 5.8.2.3.5 Particular care will have to be taken in designing the crossfalls and the rainwater disposal system, to avoid dangerous accumulation of water on the pavement (S).
  - 5.8.2.3.6 Signs indicating the toll station have to be posted ahead of it and lit in accordance with the standards set out in Chapter 4 (S).

#### 5.8.2.4 Toll Station Buildings

As a minimum, the station building shall include the following premises and systems (RP):

- (a) changing room for toll station personnel, complete with showers and restrooms;
- (b) office of the station chief, connected with the offices of the competent authorities and with the public telephone network;
- (c) storeroom for supplies of toll forms (tickets, other printed material, etc.);
- (d) strong room containing a safe for the storage of toll receipts and valuables; in stations with high traffic volumes, this room should be constructed with especially thick, reinforced concrete walls;
- (e) room containing equipment for receiving and recording the classification and toll collection data obtained from the personnel and the automatic machines;
- (f) room housing the heating and air-conditioning plant;
- (g) room housing the electric distribution board and generator.

### 5.9 Frontier Check-Points

#### 5.9.1 General

A frontier check-point is situated at or close to the frontier between two countries for frontier control services, and is provided with the necessary buildings and installations where various types of control are carried out, such as passport, customs, sanitary and phytosanitary checks of passengers and vehicles crossing the border.

#### 5.9.2 Types of Frontier Check-Points

5.9.2.1 Depending on the method of construction, technology and organization of frontier control, the frontier check-points along the TEM may be of two types:

- (a) combined type, with joint official buildings and installations necessary for carrying out frontier controls, located either on the very border line, if the area is suitable, or on the territory of one of the countries;
- (b) separate type, where all necessary buildings and installations are built separately by each country, coordinated with the competent authorities of the neighbouring country.

5.9.2.2 Joint type of frontier check-point presents advantages since it requires less construction and maintenance costs than the separate type and reduces also the delays in crossing frontiers. It may also be arranged in such a way that the exit frontier check-point is located on the territory of one country and the entrance check-point on the territory of the other country.

### **5.9.3 Technical and Operational Requirements for the Location of Frontier Check-Points**

#### 5.9.3.1 Site Location

5.9.3.1.1 Location of the border crossing depends on the alignment of the motorway and on the possibilities it offers to travellers crossing the frontier. The proper site location for the construction of a frontier complex, its type and operational organization involved should be determined by an agreement between the competent authorities of the adjacent countries.

5.9.3.1.2 Location of the site should take into account the following:

- (a) geography of the area where the frontier complex is to be built – it should be away from populated areas and have no connection with the local road network. Wherever it is considered necessary, „No Exit” passages should be foreseen for use by the staff of the frontier check-point and by official vehicles (RP);
- (b) soil characteristics;
- (c) terrain type, since flat or slightly undulating terrain should be selected, while mountainous terrain could lead to excessive expenditures (RP);
- (d) distance between the frontier check-point area and the nearest motorway interchange, which should not, under normal conditions, be less than 3,000 m (RP);
- (e) distance to service areas (restaurants, service stations, motels, etc.), which should be situated at least 3,000 m away from frontier installations (RP).

#### 5.9.3.2 Dimensions and Shape of the Frontier Site

5.9.3.2.1 These depend on traffic forecast, which should be as realistic as possible. If there is an erroneous forecast of high volumes, it will lead to superfluous expenditures. On the other hand, if the forecast is too low, there would not be enough capacity at the frontier check-point to deal efficiently with necessary controls.

5.9.3.2.2 The area of the joint frontier check-point should be about 800 m in length and about 300 to 350 m in width, with a total area of about 15 ha. This area might be reduced especially in hilly and mountainous areas where also low traffic is expected. However,



where possible, a reserve area should be set aside so that difficulties which might arise due to an unexpected increase in traffic, even for a certain period of time, could be easily overcome (RP).

5.9.3.3 Functional Layout of the Site

5.9.3.3.1 The structure and shape of the frontier complex must permit separation of passenger and goods traffic before approaching the installations where controls are carried out.

5.9.3.3.2 In order to permit drivers to find the lane they have to follow and the speed they have to maintain when approaching the check-point, reflective informative signs possibly with warning lights should be used (see Chapter 4).

5.9.3.3.3 The number of traffic lanes in the control area proper is determined depending on the density of traffic, but should not be less than three lanes in each direction for passenger traffic, i.e. (RP):

- (a) right-hand traffic lane should be intended for buses and passenger cars with trailers;
- (b) central and left-hand traffic lanes should be intended for passenger cars.

5.9.3.3.4 The lanes should be clearly outlined with horizontal markings (RP).

**5.9.4 Buildings and Installations in the Area of the Frontier Check-Point**

5.9.4.1 General

5.9.4.1.1 It is advisable to find a homogenous arrangement of buildings and installations in the area of the frontier complex so that travellers can easily and quickly proceed through the check-point. The various controls should be sufficiently functional to reduce to a minimum the time necessary for their performance without sacrificing quality.

5.9.4.1.2 Buildings and installations at the frontier check-point should correspond to the nature of the various types of frontier control to be carried out (passport, customs, sanitary, etc.), as well as to the nature of the administrative services. The basic services provided at the check-point may e.g. include currency exchange, medical service, axle load weighting, toilets and the shop selling items needed when crossing the border (RP).

## **6 ENVIRONMENTAL CONSIDERATIONS**

### **6.1 Scope**

The construction of a motorway is complicated not just by the technical and financial problems involved, but also by the need to compare different solutions and to optimize the impacts on the surrounding environment and population. In effect, the motorway must not only permit easy and safe traffic movement, but must also present pleasing aesthetic qualities and reduce as far as possible any further pollution – in the widest sense of the term – of the surroundings.

### **6.2 Environmental Impact Assessment**

#### **6.2.1 Strategic Environmental Impact Assessment (SEIA)**

6.2.1.1 Preceding the Environmental Impact Assessment of the particular project, SEIA should be applied at the strategic decision (programs) level to set the policies for the management of the transport/road sector. While co-ordinating transport/road planning with land use planning, SEIA makes it possible to limit undesirable environmental impacts, to detect potential conflicts at an early stage and to achieve efficient and sound motorway system also from the environmental point of view.

6.2.1.2 The general recommendations regarding SEIA are given in the UN/ECE document „Policies and Systems of Environmental Impact Assessment” (Environmental Series 4, Geneva, 1991).

#### **6.2.2 Environmental Impact Assessment (EIA)**

6.2.2.1 Description

6.2.2.1.1 EIA shall identify, describe and assess in an appropriate manner, in the light of each individual case, the direct and indirect effects of a project on the following factors:

- (a) human beings, fauna and flora;
- (b) soil, water, air, climate and the landscape;
- (c) material assets and the cultural heritage;
- (d) the interaction between the factors mentioned in the first, second and third indents.

- 6.2.2.1.2 EIA should contribute to avoiding costly construction delays, allows better integration of the project into the environment and familiarizes all the parties concerned with the environmental status of the proposed motorway construction site (RP).
- 6.2.2.1.3 EIA must take into account also impacts originating during the motorway construction including the location of borrow pits and waste management (S).
- 6.2.2.2 EIA Report and Its Contents  

EIA reporting is governed by the European Council Directive 97/11/EC of 3 March 1997 amending Directive 85/337/EEC on the assessment of the effects of certain public and private projects on the environment.
- 6.2.2.3 EIA Methods
  - 6.2.2.3.1 The tools generally in use for EIA are checklists, matrices and interaction diagrams, maps, prediction and evaluation methods. Also perspective drawings, photomontage, video and models can be used to visualise changes (RP).
  - 6.2.2.3.2 EIA should be based on the mixture of qualitative descriptive methods and quantitative ones (RP).
  - 6.2.2.3.3 Quantitative appraisal techniques aim at expressing the evaluation of the project numerically. Multicriteria analysis evaluates the fulfilment of each of the objectives set for a project as a quantified expression and ranks project alternatives for each objective. The rankings are presented as such, or aggregated with the aid of weights. Multicriteria analysis without explicit aggregation, based often on empirical comparison of a series of disparate impacts is used for EIA frequently.

## **6.3 Insertion into the Surrounding Environment**

### **6.3.1 Aesthetics and Landscape**

- 6.3.1.1 The layout of the TEM must satisfy objective and universal aesthetic criteria from the standpoints of the outside observer and also of the user, if possible.
- 6.3.1.2 The landscape analysis, taking into account geographical aspects (particularly geomorphology), archaeology and cultural history, visual and spatial aspects, aspects of human experience and ecological aspects makes it possible to evaluate natural and cultural landscape along the future motorway in terms of its overall

character, important characteristics and elements and man's relation to, or utilization of these.

6.3.1.3 Rural Landscape

6.3.1.3.1 Landscape and Orientation

The landscaping and motorway layout are also of importance in terms of road safety.

For this reason, the layout should be such that any dominant characteristics will reaffirm the driver's choice of directions without confusing him (RP).

6.3.1.3.2 Variety of Visual Field

The layout should offer a succession of varied and pleasing landscape motifs, avoiding visual monotony which gives rise to boredom (RP).

6.3.1.3.3 Localized Visual Effects of Landscape

Where possible, the undesirable visual effects of the surrounding landscape may be enhanced or corrected by means of suitable landscaping measures (RP).

6.3.1.3.4 Advertising Signs

Installation of advertising signs along the motorway must be forbidden (S).

6.3.1.4 Urban and Industrial Landscape

The TEM route should, where possible, avoid highly populated urban centres (RP).

6.3.1.5 Aesthetics and the Outside Observer

When inserting the motorway into the surrounding context, any possible disturbance of the historical, landscape, social and cultural fabric of the region must be avoided. Where possible, the motorway components (cuts, embankments, bridges, viaducts and overpasses) should be architecturally designed so as to be integrated into the surrounding environment (RP).

## **6.3.2 Infrastructures and Ecology**

### **6.3.2.1 Catchment Areas**

The natural runoff pattern existing prior to construction must be maintained by constructing culverts, bridges and drains as necessary (S).

### **6.3.2.2 Natural Hydraulic Regulation**

Diversion of watercourses in the construction stage should be avoided as much as possible (RP).

### **6.3.2.3 The waters diverted by the motorway or collected in underground drainage works must be suitably conveyed away and dammed, so as to avoid erosion damage (S).**

### **6.3.2.4 Mitigating Effects on Farmlands and Woodlands**

If necessary, the alterations in the farming pattern of small holdings broken up by compulsory purchase should be contemplated. To prevent harmful erosion, any deforestation must be compensated by replanting trees, suitably seeding grasses along the sides of the embankments (or cuts), and suitable provision for channelling off rainwater.

## **6.4 Anti-Noise Measures**

### **6.4.1 Guidelines Relating to Design Stage**

#### **6.4.1.1 Horizontal and Vertical Layout**

##### **6.4.1.1.1 Distance from Buildings**

Motorway must be located as far as possible from buildings in urban zones, and in any case far enough to avoid noise levels outside buildings greater than permitted by the legislation in force in the individual countries (S).

Noise limits and measurement methodologies are governed by the national standards.

##### **6.4.1.1.2 Gradients**

Design of longitudinal profile, choice of type of interchanges, traffic information and management systems can be used to mitigate negative noise impact. Long, steep gradients should be avoided (RP).

6.4.1.1.3 Hillside Stretches

Use of rigid facings (grillages, etc.) on side slopes should be avoided (RP).

**6.4.2 Guidelines Relating to Construction Stage**

Construction activities have to be organized in such a way as to minimize the related noise pollution (S).

**6.4.3 Guidelines Relating to Operation Stage**

Noise pollution of residential zones located near motorways may be reduced by means of (RP):

- (a) embankment sides and slopes covered with organic soil;
- (b) soundbreak screens, barriers and mounds;
- (c) plantations (having little noise reduction effect, but diminishing the perceived nuisance of traffic noise);
- (d) combinations of embankment and plantation;
- (e) covering of carriageways;
- (f) speed limits for commercial vehicles;
- (g) pavement design aimed at reducing tire noise;
- (h) facade insulation.

**6.5 Anti-Pollution Measures**

**6.5.1 Air Pollution**

6.5.1.1 Special care must be taken to avoid any situations of recurrent traffic congestion (S).

6.5.1.2 Design of longitudinal profile, choice of type of interchanges, traffic information and management systems and planting can be used to mitigate negative impacts on air quality.

6.5.1.3 Construction activities have to be organized in such a way as to minimize the related air pollution (S).

**6.5.2 Pollution of Watercourses and Water Table**

6.5.2.1 Pollution by Motorway Runoff Water

Protection of water sources (often yielding drinking water) receiving polluted runoff water from the motorway should be effected by means of an efficient and appropriate drainage

system(s). Constraints will derive from the national legislation in force.

6.5.2.2 Pollution by Motorway Facilities

This is governed by the national legislation in force.

**6.5.3 Protection of Fauna and Flora**

6.5.3.1 Planting of motorway reserves and adjacent areas contributes to the protection of existing flora and fauna and may provide additional habitats and migration routes for local fauna.

6.5.3.2 Construction impacts on fauna and flora are especially important and require special attention already in the design phase.

**6.6 Anti-Vibration Measures**

**6.6.1 Guidelines Relating to Design Stage**

6.6.1.1 Motorway must be located as far as possible from built-up zones (S). Where it must necessarily be in the vicinity of buildings of limited stability or containing precision instrumentation, it is advisable to adopt the following recommendations (besides those suggested in Section 6.4 of this Chapter):

- (a) avoid basing the roadway and its structures on the same rock stratum upon which the building foundations rest (RP);
- (b) provide for flexible pavements instead of rigid ones (RP);
- (c) provide bridges and viaduct structures with the minimum number of expansion joints (RP).

6.6.1.2 In order to limit vibrations, it is necessary to prevent deformation of the wearing surface. This entails:

- (a) effective protection against frost (RP);
- (b) effective drainage of surface and underground water (RP).

**6.6.2 Guidelines Relating to Construction Stage**

Construction activities must be organized in such a way as to minimize the related vibration effects (S).

**6.6.3 Guidelines Relating to Operation Stage**

6.6.3.1 In order to limit vibrations, it is necessary to prevent deformation of the wearing surface.

- 6.6.3.2 This entails:
- (a) effective protection against frost (RP);
  - (b) effective drainage of surface and underground water (RP);
  - (c) timely repair or replacement of the wearing surface when deformation has occurred (RP).

## **6.7 Protection of Slopes and Planting of Central Reserve**

### **6.7.1 Protection of Slopes on Embankments and in Cuts**

#### 6.7.1.1 General

6.7.1.1.1 Slopes of embankments and cuts should be protected from weathering by means of the following:

- (a) planting or sodding of a mixture of grass species;
- (b) planting of appropriate species of bushes;
- (c) planting of appropriate species of trees.

6.7.1.1.2 The problem of maintenance of vegetation must be taken into consideration from the moment of design.

6.7.1.1.3 The following standards are considered as general recommendations which may be applied where climatic, physical, botanical and geopedological factors permit.

#### 6.7.1.2 Formation of a Layer of Topsoil

6.7.1.2.1 To ensure proper rooting of the different varieties, the creation on the slopes of a layer of topsoil of the following thickness is recommended:

- (a) 15-20 cm for grass (RP);
- (b) 30-40 cm for special cases (where, for example, part of the embankment is given over to farming) (RP);
- (c) 50-60 cm for shrubs (RP).

6.7.1.2.2 This topsoil should be chemically neutral in nature, and sufficiently endowed with organic matter and nutrients; the beds should be free of stones, debris, roots and weeds (RP).

6.7.1.2.3 On the slopes of cuts, where it is difficult to apply a new layer of topsoil, the surface can be rendered suitable for plantations by having recourse to certain techniques to correct their chemical-physical-organic nature; these are (RP):



- (a) seeding of leguminous plants: these species have nitrogen-fixing properties and can transfer nitrates to the soil, thus rendering it suitable for subsequent crops;
- (b) application of organic and chemical fertilizers; the chemical fertilizers used should be double or triple complex chemical fertilizers;
- (c) usage of geotextiles or other aids in order to keep fertile topsoil in place until the plants themselves take over this role.

6.7.1.3 Multi-Species Grass Cover

The grass cover should be obtained by seeding a mixture of different species, taking into account local, environmental, botanic and anthropic factors (RP).

6.7.1.4 Planting of Slopes with Shrubs

Where the botanical and geopedological conditions permit, species of shrub shall be planted so as to provide virtually perennial protection against erosion and consolidate the deeper soil layers (RP).

6.7.1.5 Reafforestation

In order to provide permanent and deep consolidation of areas prone to slides, on important slopes and on the cuts at the heads of tunnels, it is necessary to have recourse to reafforestation techniques using tree species; besides serving to stabilize the slope surfaces, these will also serve to restore the landscape altered by construction operations.

**6.7.2 Landscaping on Central Reserve**

7.7.2.1 The main purpose of the central reserve greenery is to serve as an anti-glare screen.

6.7.2.2 Should shrubs be located in the reserve, their species used should show sturdy and balanced development both above and below ground level, and growth should be slow and moderate, both in height (to avoid creating a “wall effect”, annoying to drivers) and in width (to avoid diminution of carriageway visibility) (RP).

6.7.2.3 Moreover, due to difficulties in maintaining the central reserve hedge, it is important that the shrub species be highly resistant to attack by parasites, atmospheric agents and winter solvents, and in no case may they represent a danger to traffic; the hedge should thus be protected by a safety fence or else be of limited dimensions.

- 6.7.2.4 Finally, use should be made only of species which can tolerate pruning without harmful effects on growth (RP).
- 6.7.2.5 Depending upon the width of the central reserve, shrubs may be planted in rows or in groups.
- 6.7.2.6 In both cases driving monotony should be avoided by changing the species where appropriate (RP).
- 6.7.2.7 Regardless of the solution adopted, the surface of the central reserve not occupied by hedge should be provided with a mixed grass cover.

## **6.8 Public Information, Consultation and Participation**

- 6.8.1 Communication and public information have to be ensured during the design process, since public involvement is an integral part of EIA (S).
- 6.8.2 Activities to inform and involve the public should begin as early as possible (RP).
- 6.8.3 Communication with interested parties could be materialized through:
  - (a) information disclosures (public dissemination of information materials and documents);
  - (b) information gatherings (communication with residents and interest groups);
  - (c) consultation (providing opportunities for interested persons to pose questions and for the project team to obtain opinions about project alternatives);
  - (d) participation (dialogue between interested parties before key project decisions are made).
- 6.8.4 Consultation techniques could include information displays, newsletters, reports and leaflets, interview surveys, formal „public hearings” or less formal public meetings, discussions with specific groups or individuals, on-site consultations and inspection tours and rapid appraisal methods such as key informant interviews, focus group discussions, structured observation and informal surveys.
- 6.8.5 Communication with public should continue also during the construction phase (RP).

## **6.9 Monitoring**

- 6.9.1 It is recommended to install a system of monitoring (RP).
- 6.9.2 It is possible to distinguish two principal types of monitoring, i.e.:
- (a) baseline monitoring, aiming at acquiring baseline data necessary for obtaining information about the actual state of environment and the trends of its change regardless of the future impacts of the motorway;
  - (b) impact monitoring i.e. the ascertainment of the actual impacts of motorway construction and operation.
- 6.9.3 The post-construction monitoring has to satisfy one or more of the following objectives:
- (a) to assess and improve evaluation methods, especially those related to the prediction of environmental impacts;
  - (b) to provide motorway administrations/agencies with a way to monitor the efficiency of the environmental protection measures;
  - (c) to satisfy a political need to make sure that the effects of motorway on society are well understood and controlled and that this is properly communicated to the public;
  - (d) to identify possible trends in the development of environmental conditions.
- 6.9.4 The more detailed information about post-project analysis, types of monitoring, its institutional and methodological aspects and linkages between the impact assessment and post-assessment procedures contain the AECOTEM Guidelines (document TEM/CO/TEC/46, Warsaw, September 1991, Vol.I, pages 65 - 70).

## **7. BRIDGES**

### **7.1 Scope**

7.1.1 These provisions are applicable to bridges to be newly designed. Existing bridges should also be brought to the same safety level, if they have lower capacity than these provisions, through a rehabilitation and strengthening process, to which present specifications do not apply directly.

7.1.2 Two types of bridges – overpasses and motorway bridges – may be distinguished.

7.1.3 A bridge is an integral part of the motorway, the cross section of which (see Section 3.2) on the bridge should therefore remain the same.

### **7.2 Types of Structures**

In choosing structural types, methods of design and materials, the following principles should be kept in mind, in addition to the usual considerations regarding functional, structural, economic and aesthetic factors as well as durability (RP):

- (a) advisability to the nature of the terrain, including morphological and geotechnical characteristics;
- (b) conservation of nature and of soils used for farming;
- (c) durability over time of the structures with respect to limited deterioration of materials used and incorporation of devices to facilitate maintenance;
- (d) compatibility of the structures with the surrounding landscape.
- (e) Comfort of users.

### **7.3 Hydrologic and Hydraulic Considerations**

#### **7.3.1 General**

7.3.1.1 Hydrologic and hydraulic studies of bridge sites are a necessary part of the preliminary design of a bridge (S).

7.3.1.2 Hydrologic and hydraulic analysis should be elaborated in accordance with the respective national regulations (RP).

### **7.3.2 Data**

The following data have to be taken into account as a minimum when elaborating these studies and analyses:

#### 7.3.2.1 Site Data

- (a) maps, stream cross sections, aerial photographs;
- (b) complete data on existing bridges including dates of construction and performance during past floods;
- (c) available high water marks with dates of occurrence;
- (d) information on ice, debris and channel stability;
- (e) factors affecting water stages such as high water from other streams, reservoirs, flood control projects and tides.

#### 7.3.2.2 Hydrologic Analysis

- (a) flood data applicable to estimating floods at site, including both historical and maximum recorded floods;
- (b) flood-frequency curve for site;
- (c) distribution of flow and velocities at site for flood discharges to be considered in design of structure;
- (d) charge-discharge curve for site.

#### 7.3.2.3 Hydraulic Analysis

- (a) backwater and mean velocities at bridge opening for various trial bridge lengths and selected discharges;
- (b) estimated scour depth at piers and abutments of proposed structure.

## **7.4 Bridge Design Actions**

7.4.1 Structures shall be designed to carry the following loads and forces including combinations of their actions (S):

- (a) dead load;
- (b) live load;
- (c) dynamic impact actions;
- (d) wind loads;
- (e) other forces, when they exist, such as: longitudinal forces, centrifugal forces, thermal forces, earth pressure, buoyancy, creep and shrinkage forces, construction and erection loads, ice and stream current forces and earthquake loads, etc.

- 7.4.2 Traffic loads on bridges should comply with the European Standard ENV 1991 – 3 “Traffic Loads on Bridges” (RP).

## **7.5 Design General**

- 7.5.1 The design in each country has to be performed according to the national standards (S), which should comply with the EU Standards (RP).

- 7.5.2 Regarding crossfall and longitudinal gradient, the standards set out in paragraphs 3.1.8 and 3.6.2 must be observed also in case of bridges (S).

## **7.6 Detailed Requirements**

In order to keep maintenance to a minimum during operation and to facilitate operations, the following is recommended (RP):

- (a) use of materials which are highly resistant to aggressive agents;
- (b) protection of the more degradable materials with suitable means. This protection, which is customary for all metal structures, should also be applied to concrete structures, at least on those parts which are most exposed to aggressive agents;
- (c) use of waterproofing devices in the expansion joints; these devices should be easy to maintain or repair by means of simple disassembly and reassemble operations with the use of quick-hardening materials;
- (d) use of bearing fittings which are highly reliable with respect to the characteristics of the structure involved;
- (e) deck surfaces should be waterproofed and provision made for the disposal of rainwater from all parts of the structure;
- (f) access to the various critical points of the structure should be facilitated, and provisions made for repair or replacement of bearings (see Section 7.8);
- (g) contact areas on bridge seat and superstructure shall be finished so as to assure close and safe contact between the structure and bearing itself.

## **7.7 Safety Measures on Bridges**

### **7.7.1 Scope**

7.7.1.1 The provisions given hereafter provide general criteria for the construction of systems to ensure safe traffic conditions on structures.

7.7.1.2 Measures and devices aimed at holding vehicles on the carriageway, at the protection of the traffic from the consequences of sudden gusts of wind (information systems, windbreak fences, etc.) as well as to systems for the disposal of rainwater must be applied (S).

7.7.1.3 In order to improve safety, overpasses should be numbered to facilitate their identification by motorway users (RP).

### **7.7.2 Restraint Systems on Bridges**

7.7.2.1 Pedestrian parapets and safety barriers must comply with national standards (S).

7.7.2.2 In general, they could be classified according to the containment level, taking into account the European Standard EN 1317 – 6 “Road Restraint Systems”.

### **7.7.3 Safety Barriers in Approach Zones**

Approach zones to bridges must be protected by suitable safety barriers (S).

### **7.7.4 Pedestrian Parapets**

7.7.4.1 Pedestrians must be protected by parapets no less than 1.00 meter in height (S).

7.7.4.2 These should not possess footholds or projections to permit climbing over them (RP).

7.7.4.3 The motorway should be protected from all falling or thrown objects by means of screen no less than 2.50 meter in height (RP).

### **7.7.5 Restraint Systems on Motorway Bridges**

7.7.5.1 The safety barrier shall cover the length of the motorway bridge and the approach zones shall be provided with barriers as described in paragraph 7.7.3 (S).

7.7.5.2        Wherever the motorway passes over a railway or civil and industrial installation, the protective screen of minimum 2.00 meter height should be provided (RP).

7.7.5.3        The net, protecting pedestrians from falling down the space between two opposite carriageway bridges should be installed in the central reserve (RP).

### **7.7.6        Rainwater Disposal Systems**

7.7.6.1        Devices have to be provided for collection and disposal of rainwater (S).

7.7.6.2        These devices may consist of gullies, main and secondary pipes and troughs.

7.7.6.3        The number, size and location of the gullies, troughs and the diameters of pipes shall be determined on the basis of appropriate hydraulic calculations (S).

7.7.6.4        In all cases, pipe diameters cannot be less than 150 mm in order to facilitate maintenance (S).

7.7.6.5        Secondary pipes connect the gullies to the main pipes, which in turn conduct and discharge water at appropriate places.

7.7.6.6        Water discharge points should generally be located at the ends of the bridges (RP).

7.7.6.7        In case of very long structures, it is desirable to provide intermediate discharge points (RP).

7.7.6.8        Water shall not be permitted to discharge upon and thus erode the underlying parts of the structure (S).

### **7.7.7        Cleaning and Maintenance of Rainwater Disposal Systems**

7.7.7.1        Cleaning and maintenance of water disposal systems are of great importance in guaranteeing both traffic safety and the protection of the surrounding soil from possible erosion.

7.7.7.2        For the cleaning operations it is possible to make provision for appropriate flushing wells connected to the main pipes by means of suitably sized ducts (RP).

7.7.7.3        Cleaning may be effectuated by spraying water into these under sufficient pressure to clear obstructions in the pipes (RP).



## **7.8 Access to Critical Zones of Bridges and Viaducts**

- 7.8.1 In order to preserve bridges over time, a programme of inspections is required (S).
- 7.8.2 For this to yield significant and positive results, and to allow inspection to be conducted regularly and without disruption to traffic, it is essential to facilitate easy access to the critical points of bridges (expansion joints, insides of box girders, water disposal devices, cable anchors, bearings, etc.) (S).
- 7.8.3 This requirement must be kept in mind right from the design stage (S).

## **8 TUNNELS**

### **8.1 Scope**

#### **8.1.1 General**

8.1.1.1 Tunnels represent an integral part of the motorway.

8.1.1.2 The insertion of a tunnel, in particular, especially – but not only – in rough topography, is one of the most difficult tasks right from the initial design stages; as recent experience shows, the costs of such works can vary extremely from case to case, sometimes by as much as ten times, depending on the nature of the terrain involved.

8.1.1.3 Safety aspects in tunnels must be taken into account in all design phases.

8.1.1.4 The costs involved – and therefore, the decisions taken at the design stage – may be greatly affected by the rapid strides made recently in tunnel design, construction, technical systems (lighting, ventilation, traffic control equipment, etc.) and in operating procedures.

8.1.1.5 In conclusion, the decisions as to whether to construct a tunnel and what techniques to adopt have a considerable effect on the economics of the project.

#### **8.1.2 Advantages of Motorway Alignments with Tunnels**

8.1.2.1 In determining the profitability of road alignments involving tunnels, the designer should take into account both the direct and indirect benefits (such as habitat and environmental problems) and the costs (those of construction and operation, of externalities of foreseeable variations in user costs).

8.1.2.2 Among the variants considered in the analysis and comparison of costs and benefits, it may sometimes be preferable to include tunnels, even in non-mountainous terrain.

8.1.2.3 In rough terrain, better flow conditions may be achieved using tunnels.

**8.1.3 Geological and Geotechnical Studies**

8.1.3.1 Tunnels must be designed and constructed in accordance with the nature and behaviour of the surrounding terrain, the possible presence of water and all other local factors of influence (S).

8.1.3.2 In studying tunnel alternatives, special attention must be given to prior geological and geotechnical studies; these entail surface observations, surveys, borings, assays, laboratory tests, and sometimes even exploratory tunnels to determine the various types of soil present, their characteristic and their stratigraphic and tectonic relationships (S).

8.1.3.3 Particular attention must be given to the tunnel portal areas as well as to unstable or landslide zones and other areas affected by seismic action (S).

**8.1.4 Decisions Regarding Suitability of Techniques of Tunnel Construction**

8.1.4.1 Situations where tunnels might represent valid alternatives to open construction include the following:

- (a) solution of specific urban or landscape problems;
- (b) improvement of route alignment, with less need to cope with significant differences in elevation and considerable reduction in the length of the route;
- (c) crossing of unstable or barely stable hillside zones, with care taken to avoid tunnels with weak coverage in soils showing “flow” phenomena;
- (d) protection of a route against natural hazards (avalanches, falling rock, etc.) – recent experiences show that tunnels hold up well in zones hit by earthquakes;
- (e) cases where specific environmental protection is required in particularly important areas.

8.1.4.2 On the other hand, there are also difficult situations where heavy water seepage or soil instability, for example, may cause that costs outweigh the benefits of the tunnel alternative.

8.1.4.3 With regard to construction procedures, since the nature and degree of important parameters vary with every tunnel, as do the number and variety of construction techniques which may be adopted, the choice should be made on a case-by-case basis.

8.1.4.4 Finally, every tunnel is an unique structure in itself and must therefore be dealt with in an unique manner, at both the design and construction stages.

## **8.2 Guidelines Related to Technical Characteristics**

### **8.2.1 General**

- 8.2.1.1 Flow conditions occurring in tunnel sections differ from those occurring in open stretches.
- 8.2.1.2 Where tunnels are located along the route, it will therefore be necessary to ensure that continuity is not disrupted, i.e., that the capacity, service levels and safety conditions remain as similar as possible to those in open stretches (S).
- 8.2.1.3 Where this is not possible, the latter need to be adapted to the specific characteristic of underground traffic (S).
- 8.2.1.4 In general, the provision of an emergency lane in all motorway tunnels is desirable, especially should the single-tube tunnel in the initial construction stage serve two-way traffic (RP).

### **8.2.2 Capacity and Service Levels**

- 8.2.2.1 The methods used in calculating capacity and determining service levels in tunnels generally do not differ from those used in the open motorway, but lateral limitations and different light conditions have to be taken into account.
- 8.2.2.2 Factors to be taken into account include those influencing traffic in the open, specific parameters such as the length of a single tunnel, the possible existence of a series of tunnels in close succession, and the specific visibility conditions (S).

### **8.2.3 Determination of Tunnel Characteristics**

- 8.2.3.1 Number of Lanes

Once the traffic forecast is known and the service levels established, the number of lanes is determined in the same manner as for adjoining normal layouts, taking into account that it is inadvisable to reduce the number of lanes in tunnels with respect to the motorway approaching the tunnel.
- 8.2.3.2 Cross Section and Lane Width
  - 8.2.3.2.1 The tunnel cross section should provide sufficient space for necessary traffic installations and technical equipment. The ventilation and other equipment as well as signs must not reduce the traffic area.

- 8.2.3.2.2 Traffic lanes in tunnels should be of the same width as those in the adjacent normal layouts (RP).
- 8.2.3.2.3 The contingent reduction of their width, depending on local conditions (speed limitation, length of the tunnel, composition of the traffic flow) are governed by the national standards.
- 8.2.3.3 Vertical Alignment
- In tunnels, the use of maximum permitted gradients should be avoided as much as possible. The assessment of costs of lower gradient versus savings on ventilation and climbing lanes should be carried out (RP).
- 8.2.3.4 Lateral Clearance
- 8.2.3.4.1 In between the traffic lane and the curb of the service walkway, the edge line of min. 0.25 m must be safeguarded (S). In special cases (long tunnels, bore tunnels, low traffic volumes, etc.) the shoulder or emergency lane should be avoided in accordance with national standards (RP).
- 8.2.3.4.2 In order to protect pedestrians and equipment located along the wall, it is recommended that service walkways 1.00 m or at least 0.75 m wide be provided, equipped with reflectors(RP).
- 8.2.3.4.3 In the case of tunnels longer than 1000 m (RP), different solutions should be adopted case by case, depending on the specific factors involved.
- 8.2.3.4.4 In these cases, it will be necessary to provide, in addition to the service walkways, lay-bys for the parking of broken-down vehicles (see paragraph 8.2.3.7) (S).
- 8.2.3.5 Overhead Clearance
- Overhead clearance of minimum 4.50 m be left in tunnels during their full life cycle (S).
- 8.2.3.6 Pavement
- In tunnels longer than 1000 m, pavement should be cement concrete for fireproof reasons (RP).
- 8.2.3.7 Lay-Bys
- 8.2.3.7.1 Lay-bys for parking of broken-down vehicles should have a net length of min. 40 m and minimum width of 2.50 m , besides the service walkway.

- 8.2.3.7.2 The spacing of lay-bys should be determined by national regulations.
- 8.2.3.7.3 It is recommended not to locate lay-bys in horizontal curves, if possible (RP).
- 8.2.3.8 Turning Bays and Cross-Connection Tunnels
- 8.2.3.8.1 The cross section should be enlarged at certain points in long two-way tunnels to permit U-turns, at least for passenger cars (RP).
- 8.2.3.8.2 In twin unidirectional tunnels, turn-arounds should be permitted via cross-connection tunnels between the two tubes, which should also take into account possible constraints related to the ventilation systems employed (RP).
- 8.2.3.8.3 The distance intervals between the turning bays and/or cross-connection tunnels must be determined according to national regulations.
- 8.2.3.9 Pedestrian Safety Measures
- 8.2.3.9.1 In tunnels longer than 1000 m, shelters of suitable size and pedestrian escape exits should be provided along the tunnel (RP).
- 8.2.3.9.2 In addition to the contingent cross-connection tunnels for vehicles (see paragraph 8.2.3.8.2), also the cross-connection passages for pedestrians must be provided according to national standards (S).
- 8.2.3.10 Surface of Tunnel Walls
- It is recommended that the colour of tunnel walls be bright and that their surface be non-flammable and easy to clean (RP).

## **8.3. Traffic Regulation**

### **8.3.1 General**

Traffic regulation in tunnels has the following aims:

- (a) to maintain as much as possible the service level;
- (b) to regulate vehicle movement in emergency situations such as accidents, fires, etc.;
- (c) to reduce the risk of accidents;
- (d) to regulate the transit of dangerous goods.

### **8.3.2 Traffic Regulation to Avoid Lowering the Service Level**

In general, the following measures could be adopted:

- (a) prohibition of overtaking;
- (b) installation of illuminated signs and signals (S);
- (c) advance signs and direction signs must be repeated in the case of interchanges or service areas located immediately after tunnels – a situation which is in any case highly inadvisable (S);
- (d) installation of the management and information system.

### **8.3.3 Traffic Regulation in Emergency Situations**

8.3.3.1 In the event of partial or complete obstruction of the tunnel as a result of accident or fire, traffic access must be limited or barred (S).

8.3.3.2 The reduction of carriageway, change of carriageway, alternation of one-way traffic in the case of two-way tunnels, etc., must be always materialized outside the tunnel.

In case the tunnel is located on the territory of two or more countries, one operation centre only should be set up to deal with emergency situations.

8.3.3.3 Where a tunnel is blocked for a long period of time, traffic must be diverted from the motorway at the preceding interchange (S).

### **8.3.4 Traffic Regulation Regarding Heavy Vehicles and Transport of Dangerous Goods**

8.3.4.1 The transit of dangerous goods must be governed by special regulations issued by the relevant authorities in the individual countries.

8.3.4.2 In general, traffic safety requires that the transit of vehicles carrying dangerous goods be forbidden or obliged to comply with the special regulations set by national legislation (S).

### **8.3.5 Signing of Tunnel Approaches**

On tunnel approaches, the following signs should be installed in accordance with local conditions and national regulations (RP):

- (a) informative signs:
  - tunnel symbol
  - tunnel name and length
  - radio station frequency

- (b) regulatory and warning signs:
  - traffic signals
  - speed limit
  - overhead clearance limitation
  - prohibition of overtaking
  - turn on/off lights.

## **8.4 Equipment**

### **8.4.1 General**

8.4.1.1 To avoid accidents and limit their effects, it is advisable to equip tunnels – depending upon their length, traffic volumes, etc., and also on the costs involved – in order to:

- (a) control and regulate traffic;
- (b) communicate with users;
- (c) provide emergency equipment.

8.4.1.2 Technological equipment of tunnels is the following:

- (a) traffic management system;
- (b) lighting;
- (c) ventilation;
- (d) safety equipment;
- (e) communication equipment;
- (f) fire extinction equipment;
- (g) close-circuit TV;
- (h) central operation system;
- (i) energy supply;
- (j) maintenance equipment;
- (k) loudspeakers;
- (l) radio broadcasting system.

### **8.4.2 Installation**

8.4.2.1 Depending upon the specific case, the following should be further supplied:

- no-overtaking signs, danger signs, signal lights, etc.;
- variable message signs to set speed limits and possibly to reverse the flow direction or to close access to the tunnel;
- traffic counting points;
- loading gauges to control the heights of freight vehicles;
- television control;
- devices for radio transmissions and information;
- SOS and fire call posts (S);



- equipment to monitor temperature irregularities (fire detection);
- all-purpose portable fire extinguishers (RP);
- hydrants directly connected to a pressurized water system;
- equipment to measure the level of carbon monoxide, visual opacity, etc., regulating the operation of the ventilation system;
- suitable fire-proof housings for cable passages, conduits, pipes, etc. (S).

8.4.2.2 Both in the construction stage and in the operation stage, it is also necessary to install special devices designed to limit the damage caused by fire or explosion according to national regulations (S). Examples of these devices are indicated below:

- (a) an in-situ channel to collect liquids spilled on the carriageway should be provided along the whole length of the tunnel, with dimensions permitting a flow of 200 l/sec. This channel will be connected by means of siphons to the sump, located at the exit of the tunnel;
- (b) This sump should have a capacity of at least 50 m<sup>3</sup> (depending on the length of the tunnel) and be connected to the tunnel cleaning system (RP);
- (c) inspection pits with bolted-down covers, situated at least every 65 m (RP);

8.4.2.3 To increase traffic safety, it is also advisable to install fog and frost detectors ahead of the tunnel entrance and exit (RP).

## **8.5 Ventilation**

### **8.5.1 General**

In general, the feasibility of artificial ventilation should be investigated for two-way tunnels if their length exceeds 300 m (RP) and for unidirectional tunnels with the length exceeding 500 m (RP).

### **8.5.2 Natural Ventilation**

Natural ventilation in tunnels depends upon a number of variable factors difficult to evaluate, and is capable of diluting vehicle emissions only to a very limited extent.

### **8.5.3 Artificial Ventilation**

8.5.3.1 The decision about the type of the ventilation system depends on its economic performance and the safety analysis for normal

operation and the operation in case of fire, which should take into account the following (RP):

- (a) traffic volume (30<sup>th</sup> peak hour);
- (b) direction of traffic;
- (c) points of possible conflict (e.g. merging lanes);
- (d) permission and frequency of transports of hazardous goods.

#### 8.5.3.2 Ventilation Systems

The following ventilation systems are distinguished:

- (a) longitudinal, where the air draught, generated either naturally or by fans, is longitudinal;
- (b) semi-transversal, which injects fresh air along the tunnel length, while the foul air is sucked out through the portals or through shafts;
- (c) fully transversal (preferable to semi-transversal), where fresh air is injected and foul air is sucked out along the whole tunnel length.

#### 8.5.3.3 Design Limit Values

8.5.3.3.1 The choice and design of the ventilation system must be based on the following maximum permissible values (S):

- (a) CO concentration 150 ppm;
- (b) NO<sub>x</sub> concentration 25 ppm;
- (c) light extinction coefficient related to turbidity/soot  $7 \times 10^{-3}/\text{m}$ ;
- (d) maximum longitudinal air velocity 10 m/sec.

8.5.3.3.2 Furthermore, the system must be capable of extracting minimum 110 m<sup>3</sup>/sec of air from the most unfavourable point of the tunnel (S).

#### 8.5.3.4 Additional Requirements

8.5.3.4.1 Jet fans of the longitudinal system should be reversible and distributed over the entire tunnel length to minimize turbulence in case of fire.

8.5.3.4.2 With the semi-transversal and transversal systems, fresh air injection outlets should be adjusted so as to give uniform air distribution along the tunnel and their maximum spacing should be 50 m. The maximum spacing of extraction outlets is 100 m (S).

8.5.3.4.3 In case of fire it must be possible to switch the ventilation to extraction mode immediately (S).

#### **8.5.4 Pollution in the Area of Tunnel Portals**

The contaminated air expelled from the tunnel will diffuse in the atmosphere according to the conditions existing at the tunnel exit. This problem should be examined on a case by case basis and, where necessary, steps should be taken to avoid undesirable pollution.

#### **8.5.5 Recirculation between Portals**

In the case of unidirectional tunnels lying adjacent to one another, it is necessary to prevent the contaminated air expelled from one being sucked into the other as fresh air.

#### **8.5.6 Monitoring**

The following data related to the tunnel ventilation performance should be monitored (RP):

- (a) CO concentration;
- (b) turbidity/soot;
- (c) air speed and direction of air flow;
- (d) air volume and pressure increase (for semi-transversal and transversal ventilation);
- (e) fire alarm;
- (f) traffic data.

### **8.6 Lighting**

#### **8.6.1 General**

8.6.1.1 In daytime conditions drivers experience visibility problems at tunnel entrances due to the sudden drop in luminance after entry.

8.6.1.2 In order to diminish the luminance springs at the beginning and end of the tunnel, it is preferred not to locate the tunnel in the east-west direction (low sun positions).

8.6.1.3 It is also preferred to situate portals in shadowy places and to consider the construction of galleries or light-reducing facilities ahead of them (RP).

8.6.1.4 In tunnels longer than 200 m, it is advisable to consider the use of artificial lighting to permit drivers to adapt gradually to the difference in visibility conditions outside and inside the tunnel.

8.6.1.5 Where there is no lighting installed, it is recommendable to make it possible in the future by providing the respective ducts.

## 8.6.2 Lighting Sections

From the point of view of lighting, the tunnel is broken down into the following sections/zones (Figure 8a):

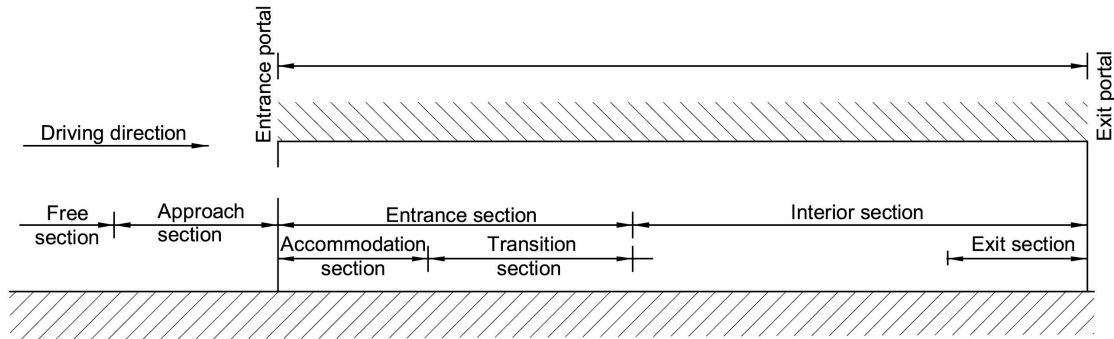

Fig. 8a - Tunnel sections breakdown for lighting purposes  
(Source: Austrian standard RVS 9.27)

- (a) approach zone;
- (b) entrance section, further subdivided into the accommodation and transition sections;
- (c) interior section (incl. exit section).

## 8.6.3 Lengths of Sections

8.6.3.1 The recommended length of the accommodation section is 150 m (RP).

8.6.3.2 The length of the transition section depends on the distance needed to reduce the luminance level at the end of the accommodation section to that of the interior section as well as on the design speed (see recommendation in paragraph 8.6.4.2) and is governed by national standards.

## 8.6.4 Daytime Luminance Levels

8.6.4.1 The minimum luminance level on the first half of the accommodation section should be 200 cd/m<sup>2</sup> (RP). It is also possible to establish the respective luminance level taking into account the lighting system used, stopping distance and approach zone luminance level, making use of Table 5.4. of the Guide for the Lighting of Road Tunnels and Underpasses (CIE – International Commission on Illumination Publication 88 – 1990).

- 8.6.4.2 The transition from this luminance level to that one on the interior section can be continuous or in stages. In this case, the maximum allowed level spring should be 1 : 3 (RP). The recommended reduction of luminance levels along the transition section may be derived from the curve presented in Fig. 5.9. of the above CIE 88-1990 Guide.
- 8.6.4.3 The average luminance level on the interior tunnel section at the highest lighting level should be 2 cd/m<sup>2</sup> (RP). More detailed recommendations regarding the interior luminance levels related to stopping distances and traffic flows are given in Table 5.5. of the above CIE 88-1990 Guide.
- 8.6.4.4 At the highest lighting level, the longitudinal  $L_{\min} / L_{\max}$  ratio along the tunnel axis should be higher than 0.55 and the absolute  $L_{\min} / L_{\text{average}}$  ratio should be higher than 0.35 (RP).
- 8.6.4.5 It is necessary to provide a short zone of 50 - 80 m of additional lighting on the exit section only in special cases (view over the sea, frequent snow, etc.) or in the case of unidirectional tunnels which might occasionally be used for two-way traffic (RP).
- 8.6.5 Nighttime Luminance Levels**
- To ensure safety at night, it is advisable to provide a low luminance level (e.g., 1 cd/m<sup>2</sup>), with also applies to short tunnels unlit at daytime (RP).
- 8.6.6 Emergency Lighting**
- The lowest level of the interior section lighting represents at the same time emergency lighting level.
- 8.6.7 Choice of Lighting System**
- The lighting system consists of direct-beam devices located above the carriageway or situated at both sides (walls). The continuous translucent panels are not recommended.
- 8.6.8 Power Supply and Control Devices**
- 8.6.8.1 It is necessary to provide for installations which, even in cases of a power cut, would instantly secure emergency lighting and power for the safety devices (signals, teletransmission, alarms, etc.).
- 8.6.8.2 Economic factors require more than one single operating regime (RP). For example, three regimes should be provided in relation to the luminance present outside the tunnel: nighttime, cloudy daylight or bright sun.

8.6.8.3 It is recommended that the maintenance requirements be taken into consideration in designing the system (RP).

### **8.6.9 Special Cases**

#### 8.6.9.1 Interchange Entries and Exits

8.6.9.1.1 The tunnel entrance section lighting cannot terminate in the area of slip roads' entries or exits.

8.6.9.1.2 In cases of location of entries or exits in the tunnel (which is not desirable generally), the level of interior lighting should be increased at least twice by shortening the light sources' spacing (RP).

8.6.9.1.3 Acceleration and deceleration lanes should be equipped by their own row of lights, providing the same (increased) luminance level as on the principal carriageway. Catseyes should be installed on the broken longitudinal line separating this carriageway from the acceleration or deceleration lane and this line should be reflectorised (RP).

#### 8.6.9.2 Escape Routes

Escape routes should be provided with permanent orientation lighting, connected to the emergency energy source. The luminance level on the escape exits should be  $1\text{cd/m}^2$  with the longitudinal  $L_{\min} / L_{\max}$  ratio higher than 0.33 (RP).

#### 8.6.9.3 Lay-Bys and Cross-Connection Tunnels

The luminance levels on lay-bys and cross-connection tunnels should be higher than these on the interior tunnel section. It is also possible to distinguish optically the lay-bys by choosing the different colour of their lighting (RP).

#### 8.6.9.4 Very Long Tunnels

8.6.9.4.1 The luminance level on the interior section could be decreased at the distance of about 1500 m from the entrance portal, but in any case should not be lower than the nighttime level (RP).

8.6.9.4.2 To contribute to the drivers' concentration, it is recommendable to create special light zones about 20 m long at every second lay-by. These light zones differentiate from the ordinary interior section by the higher luminance level (about  $10\text{cd/m}^2$ ) and different colour of lights, which may be switched on and off automatically depending on the traffic volume (RP).

## **9 MAINTENANCE RELATED TO DESIGN**

### **9.1 General Considerations**

9.1.1 The maintenance expert (or group of experts) who advises the design team shall have the task of guiding design choices towards those forms entailing minimum maintenance costs.

9.1.2 Where the designs are executed by different groups, it would be advisable to co-ordinate the maintenance aspects of the different designs (RP).

9.1.3 In cases where the new motorway or its part is to be constructed under traffic or in proximity of the existing road, measures to minimize the maintenance safety risks should be taken into account already at the design stage (RP).

9.1.4 Where the weather changes may substantially influence driving conditions, the establishment of motorway meteorological stations, monitoring atmospheric and carriageway parameters is recommended.

### **9.2 Engineering Structures**

The following points should be taken into account:

- (a) structures should preferably be of the hyperstatic type (RP);
- (b) wherever isostatic-type structures are adopted, particular arrangements should be made to ensure the protection of the structure at critical points which are prone to attack from atmospheric agents (RP).

### **9.3 Pavements**

The following points should be taken into account:

- (a) only one type of pavement (rigid or flexible) should be used except of bridges, where bituminous pavement is recommended; failing this, a homogeneous geographical or quantitative distribution of the two types should be ensured (RP);

- (b) pavement drainage generally adopted should prevent the formation of suspended water pockets, except in those soils with good drainage characteristics (RP);
- (c) suitable materials (anti-frost layers) must be used in all zones adjacent to sub-bases and subgrades affected by low temperatures (S);
- (d) construction in successive stages should be avoided as far as possible (RP);
- (e) on rigid pavements, provision has to be made for the drainage of water originating from the layer below the concrete slab (S).

#### **9.4 Embankments, Cuts and Walls**

The following points should be taken into account:

- (a) calculations shall be made of the settlement which will occur over time on embankments built on compressible soils (S);
- (b) where possible, side slopes with low crossfall should be adopted in place of protection and retaining walls (RP);
- (c) highly durable drainage devices should be adopted, including those with nonwoven fabric filters, taking into account the type of soil involved (RP);
- (d) where respective data are available, hydraulic calculations have to be carried out of all the main water disposal works (S);
- (e) easy access to drainage works should be ensured for men/machines (RP).

#### **9.5 Auxiliary Works**

The following points should be taken into account:

- (a) plants for plantations should be selected by experts on the basis of their rooting ability and resistance characteristics in relation to the local environment (RP);
- (b) choice should also depend on the type of maintenance needed (RP);
- (c) suitable ducts for motorway operation related electric and telephone cables must be provided along the route in connection with the retaining walls, viaducts and tunnels (S);
- (d) spacing of paved parts of the central reserve (crossovers) should be from 2.0 to 5.0 km; these should not be located near dangerous points (curves, reduced sight distance, etc.) (RP);



- (e) similar types of paved crossovers should be provided at both ends of engineering structures (long bridges, viaducts, tunnels, etc.) (RP);
- (f) suitable by-passes should be provided for emergencies and for winter maintenance in mountainous zones remote from entry and exit slip roads (RP).

## **9.6 Buildings**

- 9.6.1 The design has to make provision for the siting of maintenance centres and related outlying posts, including buildings to house telecommunication system relay stations (S).
- 9.6.2 The buildings for offices, machine workshops, vehicle shelters, salt supplies, etc., should be of modular type to permit enlargement at a later stage (RP).
- 9.6.3 They must be provided with suitably large paved yards to facilitate the manoeuvring by special vehicles (S).

## **9.7 Maintenance Centres**

### **9.7.1 General**

The spatial distribution and location of the motorway maintenance centres has to comply with the respective regional development plans.

### **9.7.2 Functional Organization of the Maintenance Centre**

- 9.7.2.1 The structure and organization must serve the main purpose of ensuring the traffic safety in all situations.
- 9.7.2.2 The major functions of the maintenance centre are as follows (RP):
  - (a) all cleaning operations on the motorway itself and on the right of way including the periodic cleaning of ditches and the cleaning of structures, buildings, service areas, etc.;
  - (b) all operations for cleaning and replacing markings, safety devices (fences, etc.), lighting systems, telecommunication systems, etc.;
  - (c) all repairs and replacements needed due to accident damage;
  - (d) local pavement repairs;
  - (e) mowing/pruning operations and care of plantations;

(f) all winter operations for snow and ice removal.

9.7.2.3 For winter operations, outlying posts may be set up at critical points, supplied with staff, snow equipment and chemical solvents, in direct radio contact with the maintenance centre (RP).

9.7.2.4 Such posts could also be set up for other tasks besides winter operations, if needed (RP).

9.7.2.5 All buildings, warehouses and workshops of the maintenance centre or the outlying posts should be directly connected with both carriageways of the motorway (RP).