



## Economic and Social Council

Distr.: General  
5 April 2013

Original: English

---

### Economic Commission for Europe

#### Inland Transport Committee

#### World Forum for Harmonization of Vehicle Regulations

##### 160<sup>th</sup> session

Geneva, 25-28 June 2013

Item 4.6.3 of the provisional agenda

**1958 Agreement – Consideration of draft amendments  
to existing Regulations submitted by GRSP**

### **Proposal for Supplement 1 to the 03 series of amendments to Regulation No. 29 (Cabs of commercial vehicles)**

#### **Submitted by the Working Party on Passive Safety \***

The text reproduced below was adopted by the Working Party on Passive Safety (GRSP) at its fifty-second session. It is based on ECE/TRANS/WP.29/GRSP/2012/24 not amended (ECE/TRANS/WP.29/GRSP/52, para. 30). It is submitted to the World Forum for Harmonization of Vehicle Regulations (WP.29) and to the Administrative Committee AC.1 for consideration.

---

\* In accordance with the programme of work of the Inland Transport Committee for 2010–2014 (ECE/TRANS/208/, para. 106 and ECE/TRANS/2010/8, programme activity 02.4), the World Forum will develop, harmonize and update Regulations in order to enhance the performance of vehicles. The present document is submitted in conformity with that mandate.

Annex 3, Appendix 2,

The figure, amend to read:

"

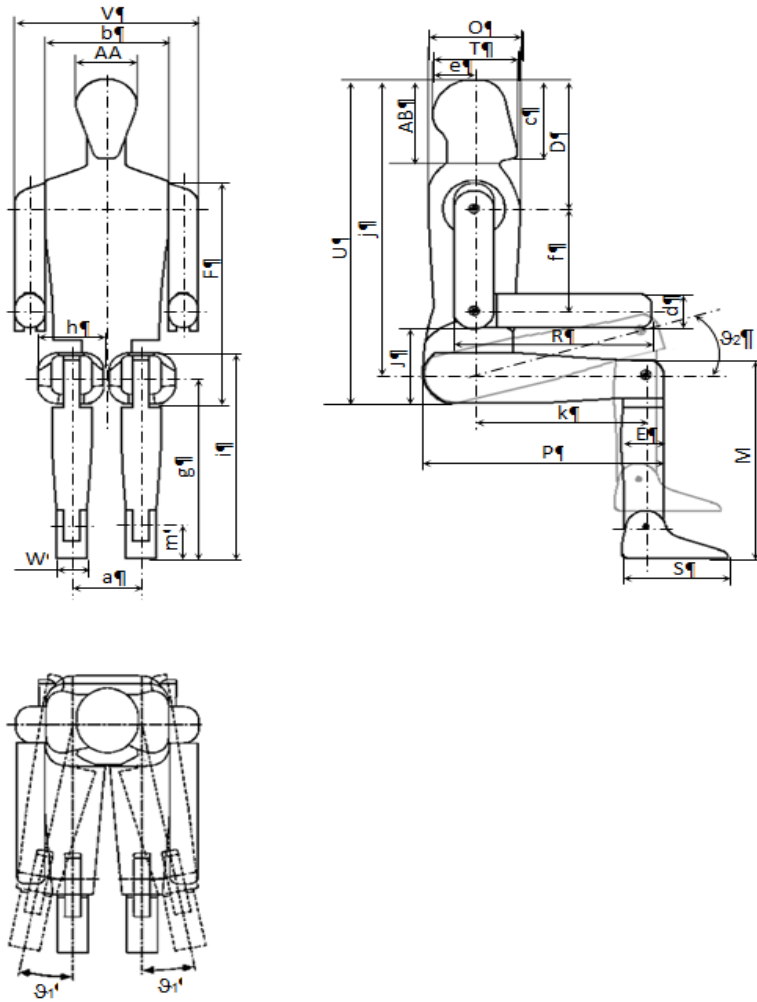

"

The table, amend to read:

"

<i>Dimensions</i>		
<i>Name</i>	<i>Description</i>	<i>Dimension, in mm</i>
AA	Breadth of head	153
...	...	...
$\theta_1$	Lateral rotation of the legs	20°
$\theta_2$	Upward rotation of the legs	45°

"