

SUB-COMMITTEE ON DANGEROUS
GOODS, SOLID CARGOES AND
CONTAINERS
18th session
Agenda item 8

DSC 18/INF.4
20 June 2013
ENGLISH ONLY

REVISION OF THE GUIDELINES FOR PACKING OF CARGO TRANSPORT UNITS

Report from tests on bedding arrangements in containers

Submitted by Slovakia and Sweden

SUMMARY

Executive summary: This document contains a comprehensive report with results from studies and full-scale tests on bedding arrangements for concentrated loads in containers, carried out in order to aid the development of the CTU Code

Strategic direction: 5.2

High-level action: 5.2.3

Planned output: 5.2.3.9

Action to be taken: Paragraph 5

Related documents: MSC 89/7/6; DSC 16/15, section 7; DSC 18/8 and DSC 18/8/1

Background

1 Based on terms of reference agreed at DSC 16, a Group of Experts has revised the *IMO/ILO/UNECE Guidelines for packing of cargo transport units* and developed it to the non-mandatory draft Code of practice for packing of cargo transport units (CTU Code) under the coordination of a consultant.

2 The last session of the Group of Experts was held at the UNECE in Geneva from 15 to 17 October 2012, where the group worked through the draft CTU Code with a view to finalizing it. After extensive changes, the group did finalize the draft CTU Code, except for the requirements for bedding arrangements of concentrated loads in containers where no consensus could be reached.

Full-scale tests on bedding arrangements for concentrated loads in containers

3 With reference to annex 14, appendix 5 of the draft CTU Code (document DSC 18/8) regarding bedding arrangements of concentrated loads in containers, Slovakia and Sweden have conducted full-scale tests in order to investigate the actual strength of containers and to validate the different proposals that have been submitted to the Group of Experts on how to facilitate concentrated loads. These full-scale tests included the loading of 58 tonnes static load in half the container length (20 as well as 40 foot containers), equivalent to 29 tonnes payload. A comprehensive report from these full-scale tests is attached in the annex to this document.

4 Based on results from these tests, a proposal on how to design bedding arrangements is submitted in document DSC 18/8/1.

Action requested of the Sub-Committee

5 The Sub-Committee is invited to note the information provided.

ANNEX

Bedding arrangements in containers (BEACON)



***Tests performed in Avesta and Helsingborg in
Sweden during April 2013***

MariTerm AB

S. Sökjer-Petersen
P. Andersson

University of Žilina

J. Jagelcak

2013-06-03

Tel. +46 (0)42 33 31 00
Fax. +46 (0)42 33 31 02

P.O. Box 74
SE-263 21 Höganäs, SWEDEN

www.mariterm.se
info@mariterm.se

Summary

As part of the revision of the IMO/ILO/UNECE Guidelines for packing of cargo transport units, MariTerm has performed a series of tests to determine the strength of containers and to suggest suitable bedding arrangements for concentrated loads.

The tests were performed in Sweden at Outokumpu's facilities in Avesta on April 4th and 5th and in the Port of Helsingborg on April 22nd.

The following types of tests were performed:

- Tests to determine the longitudinal strength of containers
- Tests to determine the transverse strength of the container floors
- Test to check the mechanical properties of wooden beams
- Tests to evaluate bedding arrangements consisting of longitudinal wooden beams
- Tests to evaluate bedding arrangements consisting of transverse wooden beams
- Tests to evaluate specific designs of cradles for heavy coils

Both 20 and 40 foot containers were used during the tests. The containers were elevated from the ground and supported underneath their corner posts. The deflection of the side beams and selected floor girders was measured before and after the loading as well as after unloading of heavy test loads, with weights corresponding to 2 times that of an actual cargo.

Conclusions

The tests showed that it is safe to load the full payload of containers on 50% of their length as long as the load is sufficiently spread to the side beams. The analysis of the tests further show that the maximum point load on the side beams at the longitudinal centre of the containers corresponds to at least 75% of the payload. Thus the load distribution curve shown below can be constructed for containers.

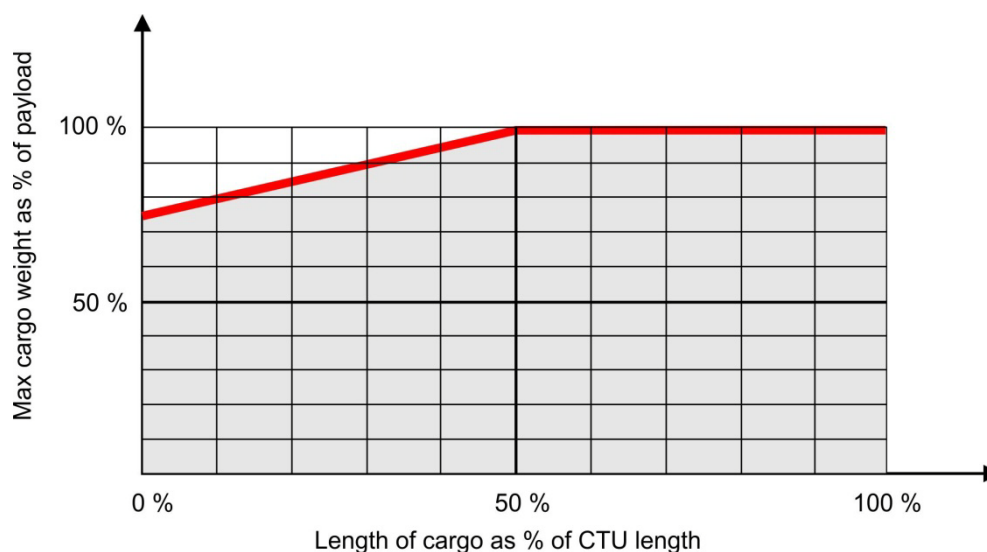

Distribution curve of allowable cargo weight in containers as a function of the longitudinal extension

Considering **the transverse strength of the floor**, it can be concluded that the flooring of the 20' and the 40' container have approximately the same strength per meter length. In both cases, the dimension design factor seems to be the fork lift test prescribed by the standard ISO 1496 (Amendment 3, 2005), and the following formulas can be used to determine the required length of cargoes:

Containers approved by C.S.C.:

Containers built in accordance with ISO 1496:

$$r = 0.2 \cdot m \cdot (2.3 - s)$$

$$r = 0.15 \cdot m \cdot (2.3 - s)$$

r = length of cargo [m]

m = mass of cargo unit [ton]

s = width of cargo (transverse distance between support points) [m]

Regarding the dimensions of **longitudinal bedding beams**, it was shown that both the principles previously proposed by Germany and Sweden are safe to use. It is thus proposed to use the following formula when designing longitudinal bedding arrangements:

$$n \cdot W = \frac{246 \cdot m \cdot (t - r)^2}{\sigma_p \cdot t} \text{ cm}^3$$

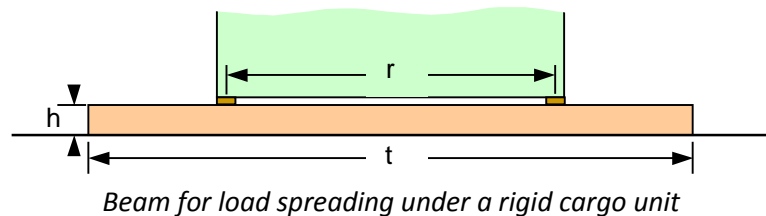

W = section modulus of one beam [cm^3]

n = number of parallel beams

m = mass of cargo unit [t]

t = length of beam [m]

r = loaded length of beam (footprint) or bridging distance [m]

σ_p = permissible bending stress in beam [kN/cm^2]

The required bending strength of **transverse bedding beams** underneath rigid cargoes should be determined by the following formulae:

W = Section modulus of support beams [cm^3]

n = Number of support beams

m = Cargo weight, [ton]

s = Cargo width, [m]

σ_p = Allowed stress in support beams, [kN/cm^2]

l_e = Contributing length of container floor [m], taken as minimum of

Beams spaced **more** than 0.84 m apart: $l_e =$

Beams spaced **less** than 0.84 m apart: $l_e =$

Contents

SUMMARY	3
CONCLUSIONS	3
1 INTRODUCTION.....	7
2 PROJECT TEAM AND ATTENDANCE	8
3 TEST EQUIPMENT	9
3.1 CONTAINERS USED DURING TESTS IN AVESTA.....	9
3.2 CONTAINERS USED DURING TESTS IN HELSINGBORG	10
3.3 CARGOES	11
3.4 LOAD SPREADING EQUIPMENT	12
3.5 MEASURING EQUIPMENT.....	13
4 TEST OF LONGITUDINAL STRENGTH OF CONTAINER.....	14
4.1 LEAD INGOTS IN A 20' CONTAINER.....	14
4.2 LEAD INGOTS IN A 40' CONTAINER.....	16
4.3 CONCLUSIONS	17
5 TEST OF TRANSVERSE STRENGTH OF CONTAINER FLOOR.....	18
5.1 20' CONTAINER - FLOOR TEST 3 x 1.15 M	18
5.2 20' CONTAINER - FLOOR TEST 3 x 0.90 M	20
5.3 40' CONTAINER - FLOOR TEST 3 x 1.15 M	21
5.4 40' CONTAINER - FLOOR TEST 3 x 0.90 M	22
5.5 CONCLUSIONS	23
6 FORK LIFT TEST	24
6.1 20' CONTAINER.....	24
6.2 40' CONTAINER.....	25
6.3 CONCLUSIONS	26
7 TEST OF MECHANICAL PROPERTIES OF WOODEN BEAMS	28
8 TEST OF LONGITUDINAL BEDDING BEAMS	29
8.1 20' CONTAINER – 200x200 MM.....	29
8.2 20' CONTAINER – 150x150 MM.....	31
8.3 CONCLUSIONS	33
9 TEST OF TRANSVERSE BEDDING BEAMS	34
9.1 20' CONTAINER – 3 PCS 100x100 MM.....	34
9.2 20' CONTAINER – 2 PCS 125x125 MM.....	36
9.3 CONCLUSIONS	37
10 TEST OF SPECIFIC CRADLE DESIGNS FOR COILS.....	38
10.1 WOODEN CRADLE	38
10.2 COIL-TAINER	39
APPENDIX 1 – CONTAINERS.....	40
CONTAINERS USED IN TESTS IN AVESTA	40
CONTAINERS USED IN TESTS IN HELSINGBORG	43
APPENDIX 2 – CARGO.....	45
STEEL SLABS (AVESTA).....	45
STEEL COILS (AVESTA)	46
LEAD INGOTS (HELSINGBORG).....	46

1 Introduction

As part of the revision of the IMO/ILO/UNECE Guidelines for packing of cargo transport units, MariTerm has performed a series of tests to determine the strength of containers and to suggest suitable bedding arrangements for concentrated loads.

The tests were performed in Sweden at Outokumpu's facilities in Avesta on April 4th and 5th and in the Port of Helsingborg on April 22nd.

The following types of tests were performed:

- Tests to determine the longitudinal strength of containers
- Tests to determine the transverse strength of the container floors
- Test to check the mechanical properties of wooden beams
- Tests to evaluate bedding arrangements consisting of longitudinal wooden beams
- Tests to evaluate bedding arrangements consisting of transverse wooden beams
- Tests to evaluate specific designs of cradles for heavy coils

The largest dynamic factor for test loading of containers in the ISO 1496 standard is $f_{dyn}=2$. Thus the loads used in the tests shall be considered to represent actual cargo with 50% of the weight used in the tests.

Both 20 and 40 foot containers were used during the tests. The containers were elevated from the ground and supported underneath their corner posts. The following was measured before, during and after the loading as well as after unloading of heavy test loads:

- Deflection of side beams relative the underside of the corner posts
- Deflection of the side beams and selected transverse floor girders relative the ground
- Absolute vertical position of side beams at the centre of the container

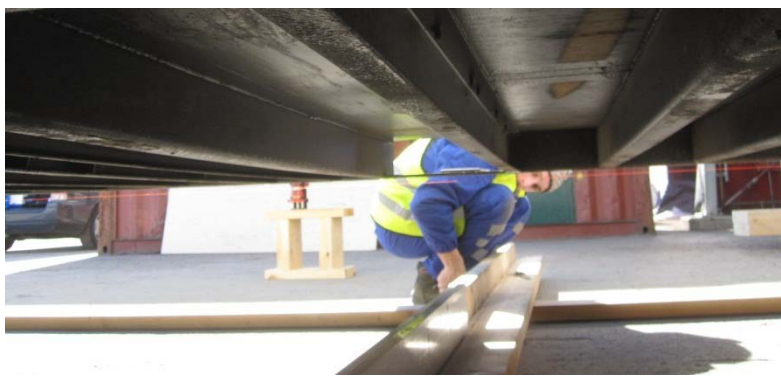

Measuring of deflection

In none of the tests performed, any permanent deformation of the containers was noted. All containers resumed their original shape after unloading.

2 Project team and attendance

The BEACON project has been supported by financing and participation by the following organisations:

- Swedish Transport Agency
- Outokumpu Stainless AB
- AB Sandvik Materials Technology
- Port of Helsingborg
- Coil-Tainer Limited
- GSL Global Steel & Logistics AB
- Uddeholms AB
- Ovako Steel AB

The tests have been supervised and documented by:

- MariTerm AB
- University of Žilina, Slovakia

The following persons were attending the tests:

Avesta – 4th and 5th April 2013

Mats Olsson - Outokumpu
Matz Olsson – Outokumpu
Dirk van Landeghem – Coil-Tainer
Niklas Sahlberg - GSL
Peter Andersson – MariTerm AB
Sven Sökjer-Petersen – MariTerm AB
Juraj Jagelcak – University of Zilina



Attendance in Avesta

Helsingborg – 22nd April 2013

Johan Lindgren – Swedish Transport Agency
Carl-Gustav Nordin – Port of Helsingborg
Mats Olsson - Outokumpu
Peter Andersson – MariTerm AB
Sven Sökjer-Petersen – MariTerm AB



Attendance in Helsingborg

3 Test equipment

The containers, test loads and measuring equipment used during the tests are briefly described below. Detailed information on the containers and cargoes are found in Appendix 1 and 2 respectively.

3.1 Containers used during tests in Avesta

3.1.1 20' container – 22G1



20' MAERSK container 22G1 (MRKU 915243-5) used in tests in Avesta with a payload of 28.3 ton.

3.1.2 40' high-cube container – 45G1



40' TEXTAINER container 45G1 (TGHU 803924-3) used in tests in Avesta with a payload of 26.6 ton.

3.2 Containers used during tests in Helsingborg

3.2.1 20' container – 22G1



20' CRONOS container 22G1 (CRXU 312110-7) used in tests in Helsingborg with a payload of 28.2 ton.

3.2.2 40' high-cube container – 45G1



40' CRONOS container 45G1 (CRXU 983868-8) used in tests in Helsingborg with a payload of 28.6 ton.

3.3 Cargoes

3.3.1 *Steel slabs (Avesta)*



Steel slabs of various weights, each with a length of approximately 4 meters.

3.3.2 *Steel coils (Avesta)*



Steel coils weighing approximately 20 ton each.

3.3.3 *Lead ingots (Helsingborg)*



Bundles of lead ingots, weighing approx. 1 075 kg each.

3.4 Load spreading equipment

3.4.1 Timber

The following timber battens were used to spread the load on the container floor.

Cross section [mm]	Length [mm]	NOTE
200 x 200	4000	4 pcs 200x50 nailed together
150 x 150	4000, 2300	2 pcs 150 x 75 nailed together
125 x 125	2300	1 pcs
100 x 100	4000, 3000, 2300	1 pcs
100x50	400, 180	1 pcs

3.4.2 Wooden Coil cradle



Outer dimensions: 2300 x 2000 x 700 mm, Mass: approximately 450 kg

3.4.3 Coil-Tainer

CLASS I / CLASS III Pallet Combination



Max Coil Weight: 25,000 kgs, Outer dimensions: 2300x2900 mm, Mass: Approx. 400 kg

3.5 Measuring equipment

To measure the deflection of the container side rails and the cross members, the following equipment was used.

3.5.1 *BOSCH DLE 50 laser distance measurement*

A laser device was fixed to a sliding beam which was placed on wooden planks under the container floor. The vertical distance at the measuring points on the side rails and cross members was measured before loading, after loading and after unloading of a cargo.



Measuring range: 0.05 m to 50 m, Display: 1 mm, Accuracy: 1 mm

3.5.2 *Digital calliper*

A digital calliper was used to measure selected dimensions of the side rails and cross members and the deflection at the measuring points on the side rails from a string installed longitudinally under the corner fittings on each container side.

Measuring range:	0 – 150 mm
Accuracy:	DIN 862
Measuring system:	non-contact linear CAP measuring system
Display:	
Repeat Accuracy:	0.01 mm
Measuring speed:	0.01 mm
Data output:	max. 1,5 m/s
Impact of humidity:	RS 232 serial output no impairment given RH 0-80%



4 Test of longitudinal strength of container

In the tests performed to evaluate the longitudinal strength of the containers, lead ingots were loaded on 50% of the containers' length. The ingots were placed on transverse beams that rested on longitudinal beams at the containers' side beams, so that the weight of the cargo was distributed to the sides without loading the floor.

In both tests of the 20 and the 40 foot containers, the weight of the test load was some 58 tons, which is approximately 2 times the payload of some 28 tons.

The tests were performed in the Port of Helsingborg on April 22nd 2013. In this set of tests, only the deflection of the side beams on both sides was measured.

4.1 Lead ingots in a 20' container

Length of load:	3158 mm
Test load:	58.64 ton
Corresponding cargo weight:	29.32 ton
Payload	28.23 ton
Max deflection:	4.9 mm



In the diagram below, the measured deflection of the side beams has been plotted along with the theoretical deflection of an ideal beam. (*The moment of inertia for the container, taking only the top and bottom side beams into account and disregarding the side walls, roof and flooring have been calculated to 60 dm⁴*).

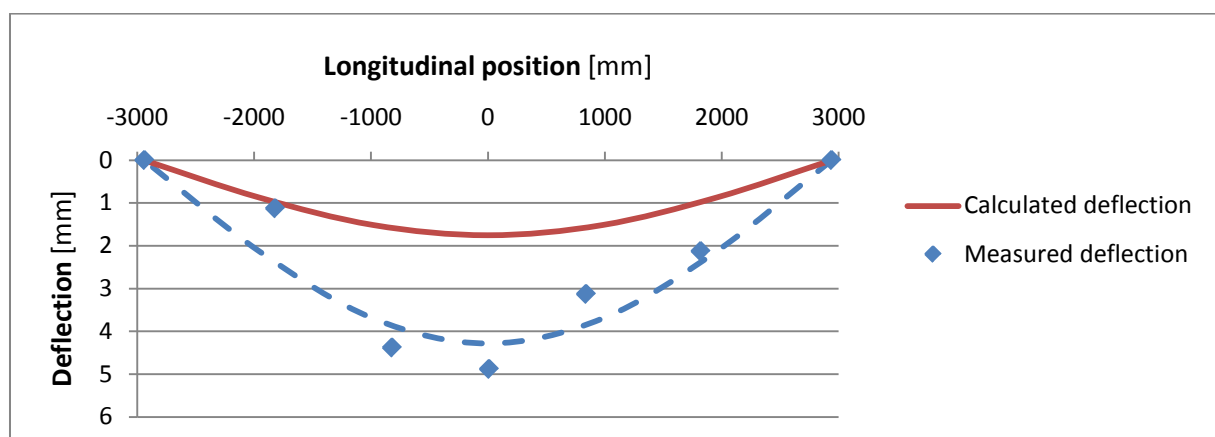

As can be seen in the diagram, the 20' container is not acting as an ideal beam, most likely due to the fact that at these deflections, the side walls are not transferring all stress to the top beam. The measured deflection of the container corresponds to a beam with a moment of inertia of 25 dm^4 . Based on this the following conclusions can be drawn, considering a dynamic factor of $f_{\text{dyn}}=2$:

- The maximum point load at the longitudinal centre of such beam would correspond to 79% of the container's payload.
- The minimum extension of a cargo with a weight equal to the payload would be 2440 mm.

In a set of FEM analysis performed by Marc Juwet at the KAHO Sint-Lieven University in Belgium, a similar set up was checked. In this analysis a coil with a weight of 26 tons and a length of 1 meter was placed on transverse beams, as illustrated in the figure below. Also in these calculations, a dynamic factor of 2 in the vertical direction was used.

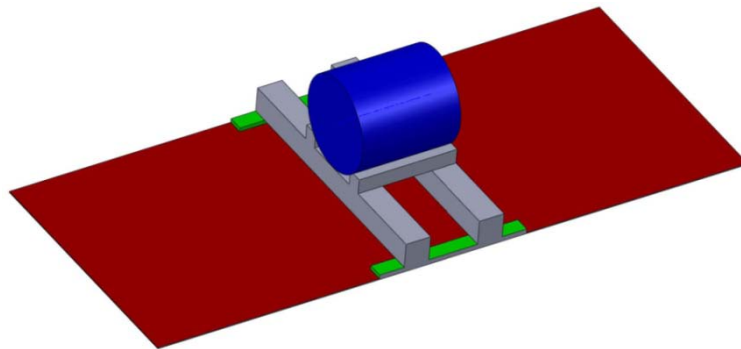

Set up for FEM analysis for 26 ton coil on transverse beams.

The FEM analysis indicates a maximum deflection of the side beams of approximately 4 mm, which corresponds well with the results of the full scale tests.

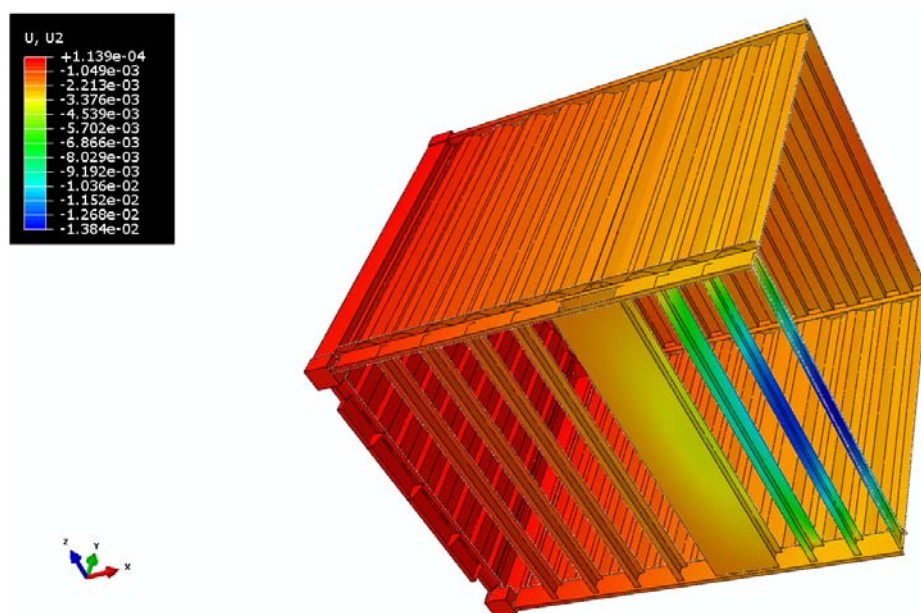

Deflection in the vertical direction found by FEM analysis of a 20 foot container.

4.2 Lead ingots in a 40' container

Length of load:	5634 mm
Test load:	58.02 ton
Corresponding cargo weight:	29.01 ton
Payload	28.60 ton
Max deflection:	16.5 mm



In the diagram below, the measured deflection of the side beams has been plotted along with the theoretical deflection of an ideal beam. (*The moment of inertia for the container, taking only the top and bottom side beams into account and disregarding the side walls, roof and flooring have been calculated to 60 dm⁴*).

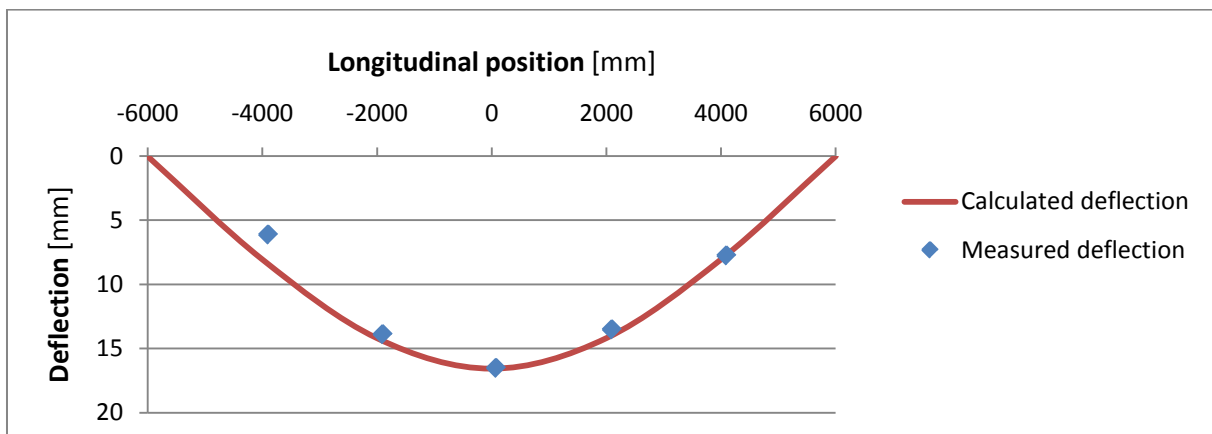

As can be seen from the diagram, the 40' container is acting very close to an ideal beam. Based on this the following conclusions can be drawn, considering a dynamic factor of $f_{dyn}=2$:

- The maximum point load at the longitudinal centre of such beam would correspond to 88% of the containers payload.
- The minimum extension of a cargo with a weight equal to the payload would be some 2700 mm.

4.3 Conclusions

The 20' container utilizes only a part of the theoretic moment of inertia while the 40 foot container utilizes almost all, but in none of the tests the containers showed any trace of permanent deformation, so it can be concluded that it is safe to load the full payload of containers on 50% of their length as long as the load is sufficiently spread to the side beams.

The analysis of the tests further show that the maximum point load on the side beams at the longitudinal centre of the containers corresponds to at least 75% of the payload. Thus the load distribution curve shown below can be constructed for containers.

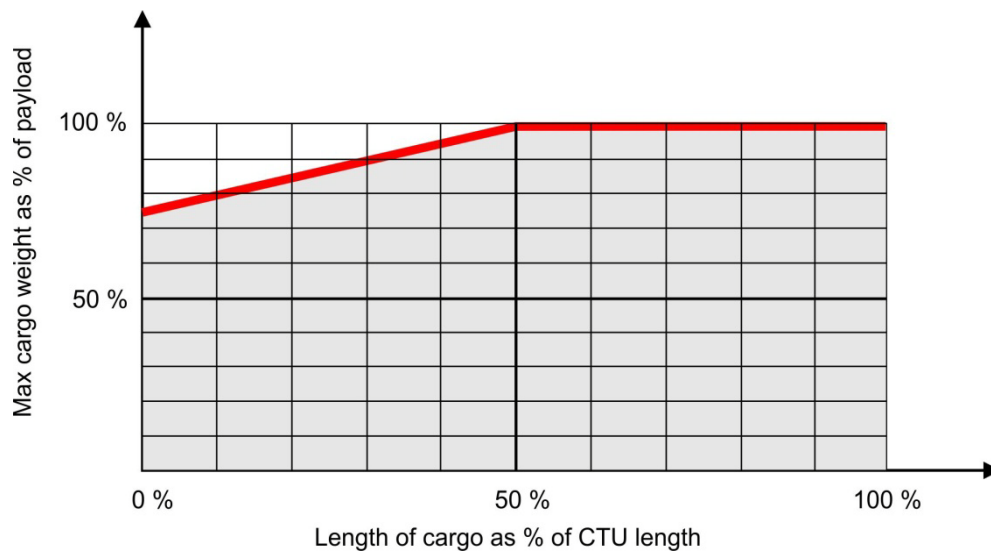

Distribution curve of allowable cargo weight in containers as a function of the longitudinal extension

5 Test of transverse strength of container floor

In order to test the ability of the container floor to spread loads in the transverse direction to the side beams, steel slabs were loaded on 2 longitudinal wooden beams with a length of 3 meters and varying spacing in the transverse direction. The weight of the test load was uniformly spread over the full length of the beams.

The tests were performed in Avesta on April 4th and 5th.

5.1 20' container - Floor test 3 x 1.15 m

Length of load:	3000 mm
Spacing of beams:	1150 mm
Test load:	26.55 ton
Corresponding cargo weight:	13.28 ton
Payload	28.31 ton



The spacing of the longitudinal beams of 1150 mm used in this test was calculated in accordance with the formula proposed by Sweden as well as Germany to the Group of Experts in September 2012 for taking the transverse strength of the floor into account:

$$t = 0.1 \cdot f_{dyn} \cdot m \cdot (2.3 - s)$$

$$m = \text{mass of cargo unit} = 26.55 \cdot 50\% = 13.3 \text{ ton}$$

$$s = \text{spacing distance of beams [m]}$$

$$t = \text{length of beams} = 3.0 \text{ m}$$

$$f_{dyn} = \text{vertical acceleration factor} = 2$$

The deflection of the transverse girders indicated in the figure below was measured before and after loading as well as after unloading.

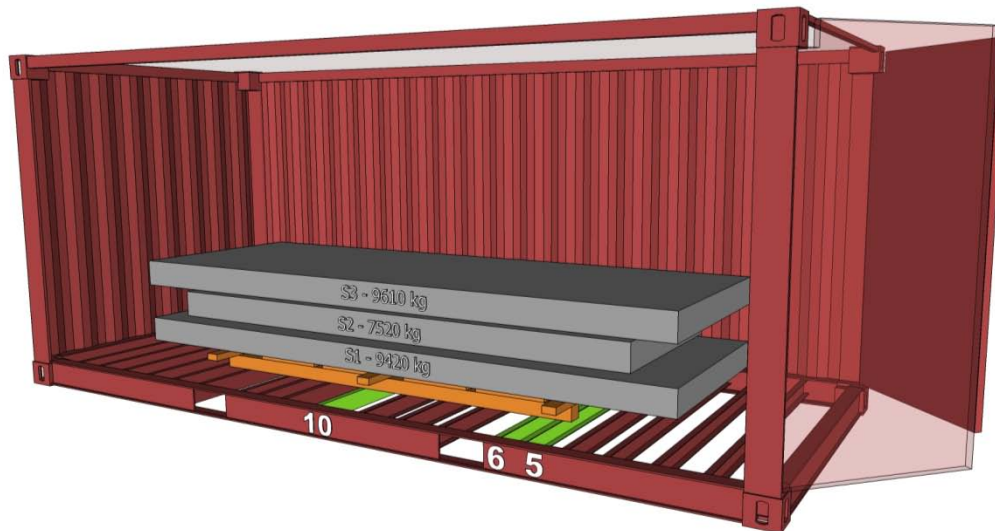

Set up of test of transverse strength. Deflection was measured for girders marked in green.

In the diagram below, the deflection of the three girders has been plotted along with the theoretical deflection (based on a moment of inertia of 175 cm^4) for both a freely supported beam and a beam fixed at its ends. In the theoretic curves, it has been assumed that the load is uniformly distributed over 10 girders.

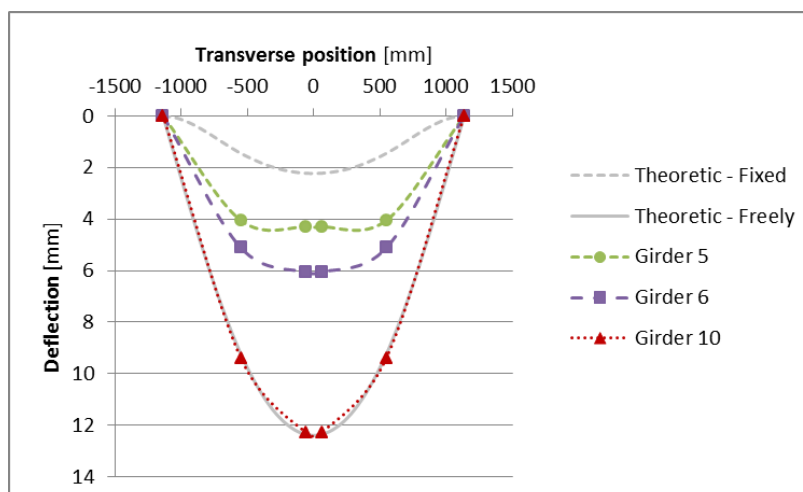

Deflection of girders relative to the side beams for a load of 26.55 tons

As can be seen in the diagram, the girder at the centre of the container (Girder 10) behaves very much as could be expected from a freely supported beam, while the beams near the end of the load show much less deflection. This is due to the fact that the side beams are not twisting as much at this location and the girders behave more like beams fixed at the ends, as well as the influence of the unloaded part of the floor.

The estimated maximum bending stress in the central girder (Girder 10) has been estimated to some 255 MPa, which corresponds to approximately 75% of the stress allowed by the elastic limit of the material.

5.2 20' container - Floor test 3 x 0.90 m

Length of load:	3000 mm
Spacing of beams:	900 mm
Test load:	26.55 ton
Corresponding cargo weight:	13.28 ton
Payload	28.31 ton



During loading

In this test, the spacing of the beams had been reduced compared to the required spacing suggested by the formula described in the section above. The deflection of the girders was measured at the same locations.

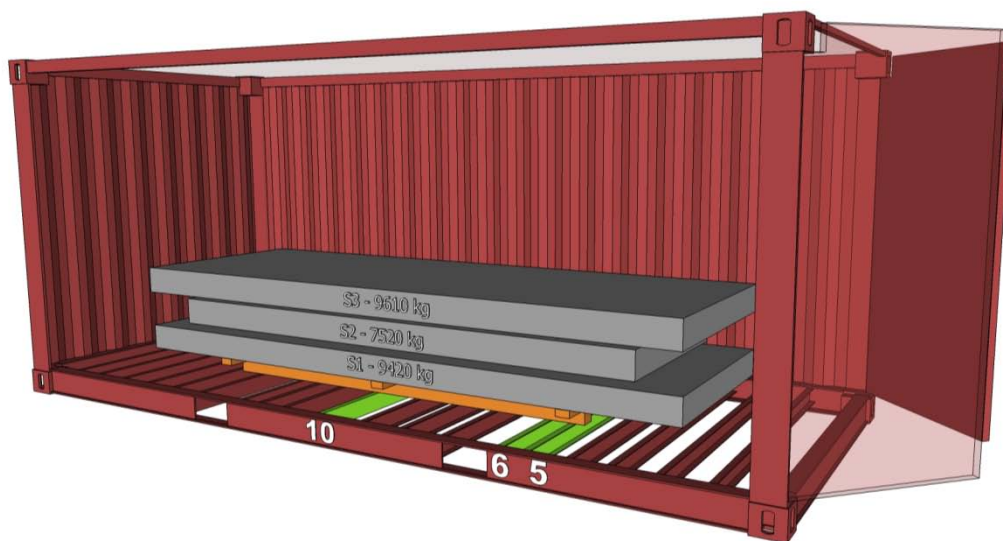

Set up of test of transverse strength. Deflection was measured for girders marked in green.

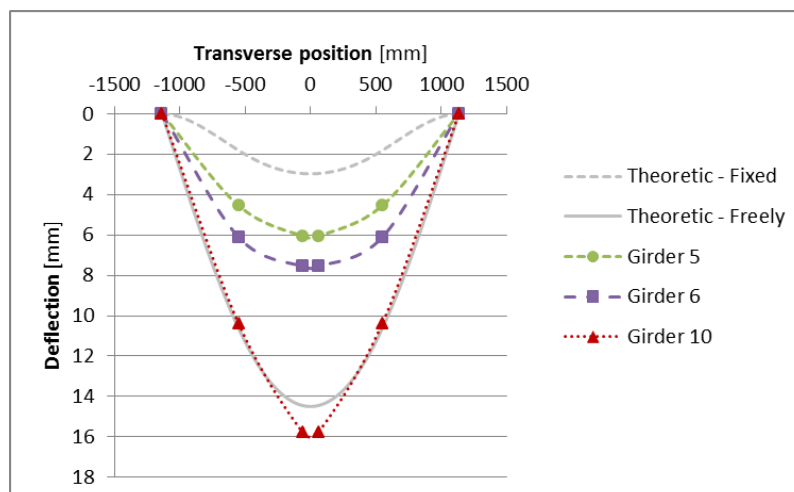

Deflection of girders relative to the side beams for a load of 26.55 tons

The results in this test were very similar to the test with a spacing of 1150 mm, which indicates that the proposed formula is on the conservative side. The estimated maximum bending stress in the central girder (Girder 10) has been estimated to some 330 MPa, which corresponds to approximately 95% of the stress allowed by the elastic limit of the material.

5.3 40' container - Floor test 3 x 1.15 m

The floor strength in the 40' containers was tested with exactly the same test loads as had been used in the 20' container.

Length of load: 3000 mm
 Spacing of beams: 1150 mm
 Weight of load: 26.55 ton
 Corresponding cargo weight: 13.28 ton
 Payload 26.63 ton



During loading

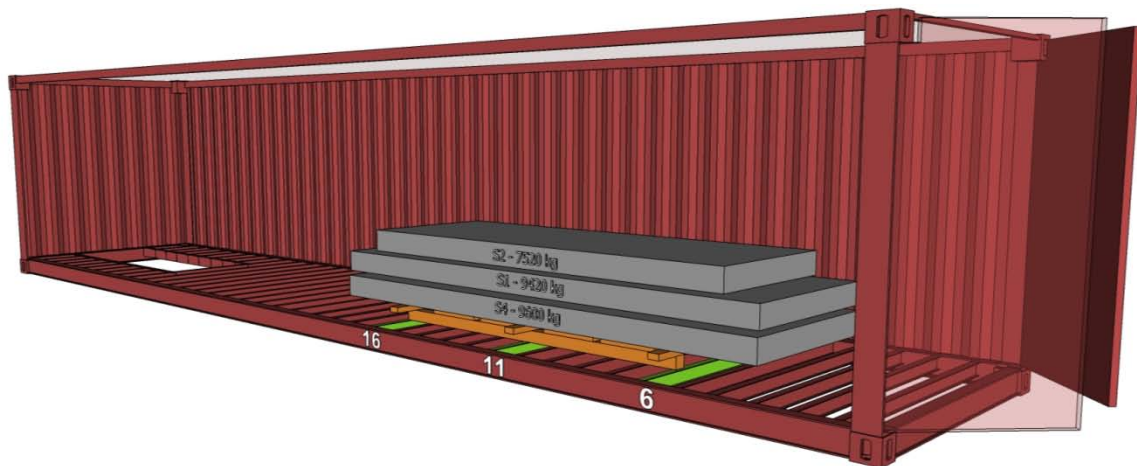

Set up of test of transverse strength. Deflection was measured for girders marked in green.

In the diagram below, the deflection of the three girders has been plotted along with the theoretical deflection (based on a moment of inertia of 168 cm^4) for both a freely supported beam and a beam fixed at its ends. In the theoretic curves, it has been assumed that the load is uniformly distributed over 10 girders.

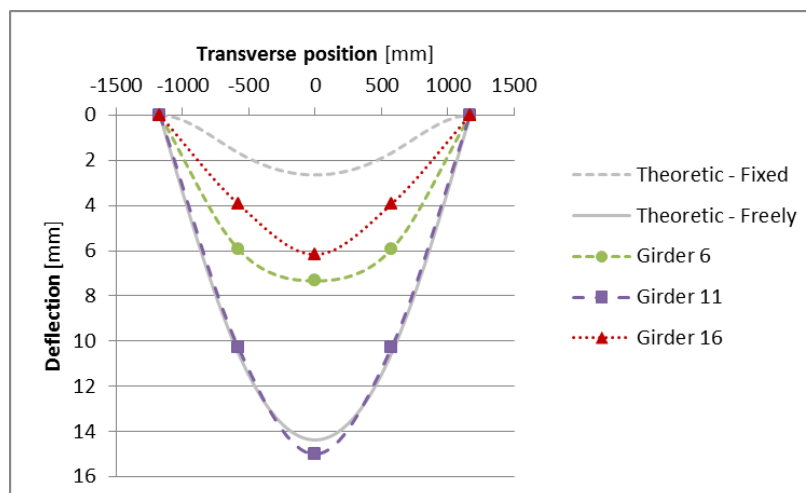

Deflection of girders relative to the side beams for a load of 26.55 tons

The estimated maximum bending stress in the central girder (beam 11) has been estimated to some 330 MPa, which corresponds to approximately 95% of the stress allowed by the elastic limit of the material.

5.4 40' container - Floor test 3 x 0.90 m

Length of load:	3000 mm
Spacing of beams:	900 mm
Test load:	26.55 ton
Corresponding cargo weight:	13.28 ton
Payload	26.63 ton

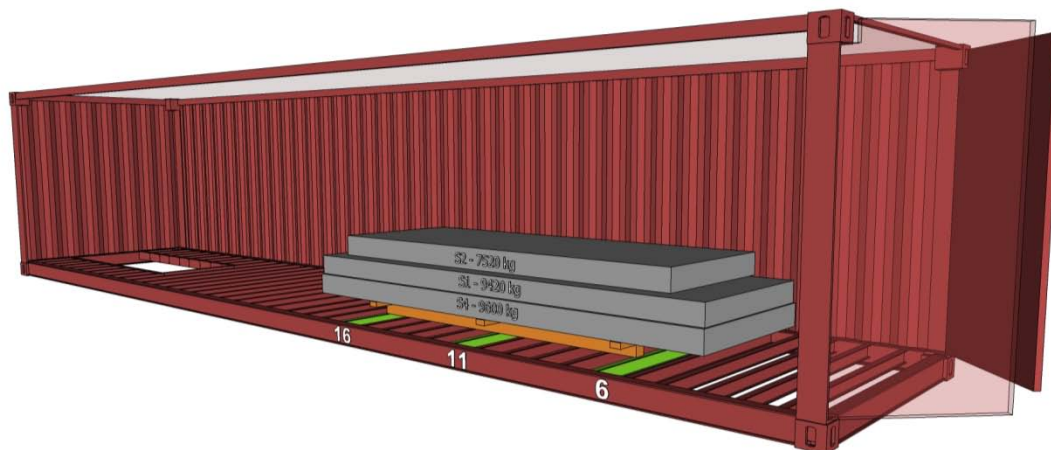

Set up of test of transverse strength. Deflection was measured for girders marked in green.

In the diagram below, the deflection of the three girders has been plotted along with the theoretical deflection (based on a moment of inertia of 168 cm^4) for both a freely supported beam and a beam fixed at its ends. In the theoretic curves, it has been assumed that the load is uniformly distributed over 10 girders.

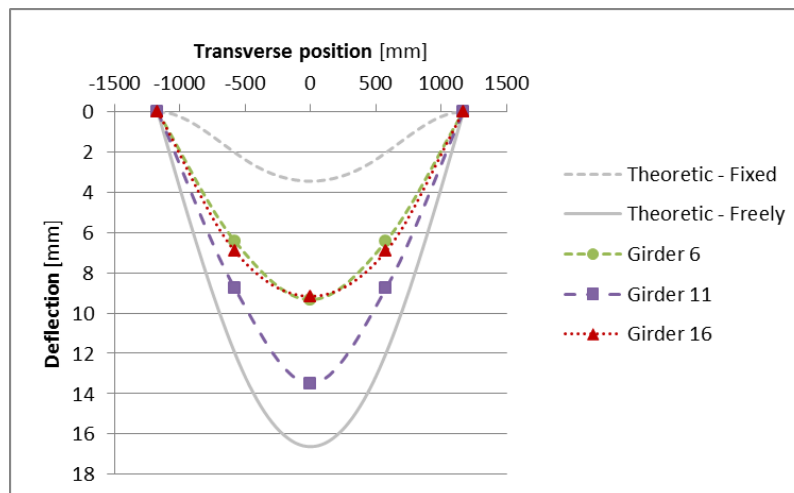

Deflection of girders relative to the side beams for a load of 26.55 tons

The test of the 40' container shows that it has a strength per meter floor length that is very similar to that of the 20' container. This suggests that there is dimensioning factor governing the design container floors, higher than the load from a uniformly distributed payload.

The estimated maximum bending stress in the central girder (Girder 11) has been estimated to some 310 MPa, which corresponds to approximately 90% of the stress allowed by the elastic limit of the material.

5.5 Conclusions

It can be concluded that, when considering the strength of the transverse girders, they can be considered as being "freely supported" at their ends. This is due to the slight twisting of the side beams. The deflection of the central girders underneath the test load corresponds very well to the theoretic deflection of girders if the inertia of the plywood is disregarded. Girders at ends of load show less deflection, partly due to influence of nearby unloaded girders.

Furthermore, it can be concluded that the flooring of the 20' and the 40' container has approximately the same strength per meter length.

In all tests, the estimated stress in the transvers girders was well below the elastic limit of the material and there were no signs of permanent deformation. Thus the formula previously proposed to the group of experts for taking transverse strength of containers into account can safely be applied.

6 Fork lift test

These tests were performed in order to simulate the fork lift test prescribed by the ISO standard 1496 (Amd. 3, 2005). These tests were used as a reference for the behaviour of the container floor in other tests performed in this project.

In the tests, steel slabs weighing 15.2 tons in total were placed on four wooden blocks with a transverse spacing of 760 mm, so that each set of two blocks was loaded with a weight of 7.6 tons. The wooden blocks were placed on strips of rubber. At one end they were placed directly on top of a transverse girder and in the other end they were placed on the plywood halfway between two girders.

6.1 20' container

Longitudinal spacing:	2850 mm
Transverse spacing:	760 mm
Test load:	15.2 ton
Corresponding axle load:	7.6 ton
Payload	28.31 ton



The deflection of the transverse girders indicated in the figure below was measured before and after loading as well as after unloading.



Set up of test to simulate the impact from a fork lift with an axle load of 7.6 tons. The deflection was measured for girders marked in green.

In the diagram below, the deflection of two girders has been plotted along with the theoretical deflection (based on a moment of inertia of 175 cm^4) for a freely supported beam loaded with a weight corresponding to 1/3 of the test load of 7.6 tons per axle.

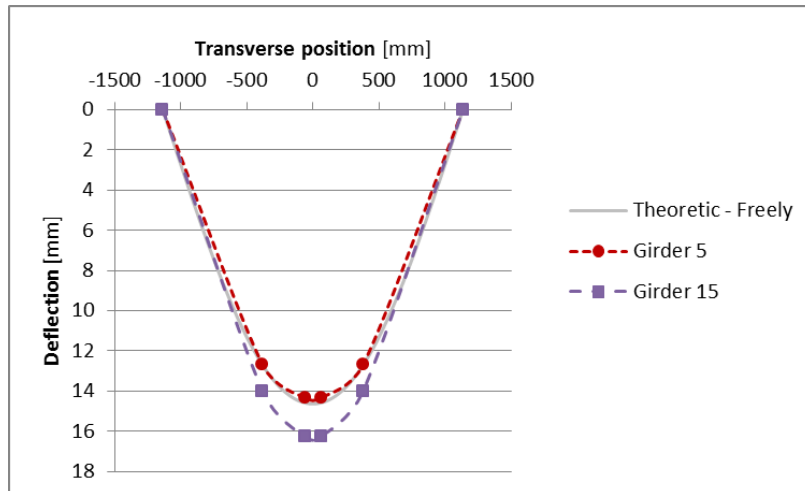

Deflection of girders relative to the side beams during the fork lift test.

6.2 40' container

The fork lift test was simulated in the 40' container in exactly the same way as in the 20' container.

Longitudinal spacing: 2850 mm
Transverse spacing: 760 mm

Weight of load: 15.2 ton
Payload 26.63 ton



The deflection of the transverse girders indicated in the figure below was measured before and after loading as well as after unloading.

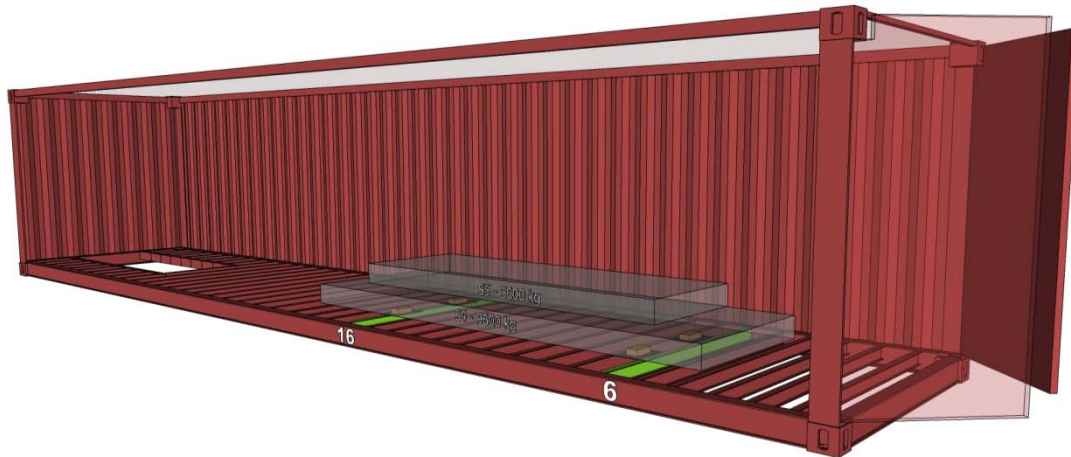

Set up of test to simulate the impact from a fork lift with an axle load of 7.6 tons. The deflection was measured for girders marked in green.

In the diagram below, the deflection of two girders has been plotted along with the theoretical deflection (based on a moment of inertia of 168 cm^4) for a freely supported beam loaded with a weight corresponding to 1/3 of the test load of 7.6 tons per axle.

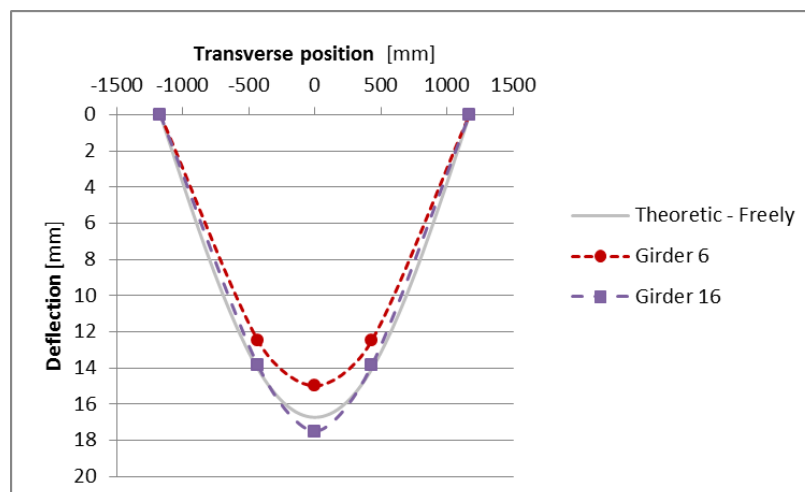

Deflection of girders relative to the side beams during the fork lift test.

6.3 Conclusions

It can be concluded that the girders directly underneath the load are taking up 1/3 of the load on each axle, the rest is spread to adjacent girders.

Also this test indicates that the 20' and the 40' container have approximately the same strength per meter floor length.

The estimated stresses in the girders are close to the tensile stress. This indicates that this test has been the dimensioning design criteria of the container floor, rather than designing them for a perfectly uniformly distributed payload.

Based on the fact that the girders closest to the footprint of the forklift are taking up 1/3 of the “axle load” it can be concluded that each girder must be designed to withstand a bending moment of 0.93 tonm if they are built in accordance with the ISO 1496 standard, according to which container floors should be tested by maneuvering a fork lift with an axle load of 7.26 ton on them.

Similarly, girders of containers approved by C.S.C., and thereby subjected to testing with a forklift with an axle load of 5.46 ton, must be able to withstand a bending moment of 0.70 tonm.

With a mean longitudinal spacing of the girders of 0.28 m and considering a dynamic factor $f_{dyn}=2$ in the vertical direction, it can be concluded that the following formulas should be used for determining the minimum length of cargoes, based on their width:

Containers approved by C.S.C.:

$$r = 0.2 \cdot m \cdot (2.3 - s)$$

Containers built in accordance with ISO 1496:

$$r = 0.15 \cdot m \cdot (2.3 - s)$$

r = length of cargo [m]

m = mass of cargo unit [ton]

s = width of cargo (transverse distance between support points) [m]

This is further supported by the tests of the transverse floor described in chapter 5 above, where the test load was placed on longitudinal beams with spacing in accordance with the first of the formulas as well as a spacing close to that derived from the second formula.

7 Test of mechanical properties of wooden beams

The mechanical properties for the wood commonly used as bedding material was tested by measuring the deflection for wooden beams loaded with lead ingots.

Free length of beams: 2000 mm
Number of beams: 3 pcs
Dimensions of beams: 150 x 150 mm

Weight of load: 11.6 ton

Maximum deflection: 5.0 mm



The maximum deflection at the centre of the beams was measured to 5.0 mm. No permanent deformation of the wood was noticed. This indicates that the wood has a modulus of elasticity of approximately 19 GPa and is able to withstand bending stress of at least 1.8 kN/cm².

8 Test of longitudinal bedding beams

These tests were performed in order to evaluate the required dimensions of wooden beams in bedding arrangements used to spread the load in the longitudinal direction.

The dimensions of the beams used in the tests were based on the proposals that have been made by Germany and Sweden, for a cargo weight of 13.3 tons and a length of 2.3 meters. The transverse spacing of the beams was 0.8 meters.

8.1 20' container – 200x200 mm

In this test the formulas in the German proposal had been used to calculate the required dimensions of the longitudinal wooden beams:

The necessary section modulus W of **each** of the two beams should be determined by:

$$W = 60 \cdot m \cdot (t - r)$$

W = necessary section modulus W of **each** of the two beams [cm^3]

m = mass of cargo unit [t]

t = length of longitudinal beams, the greater of t_1 and t_2 [m]

r = bedding length of cargo unit [m]

The required length was 4 meters and the cross section was 200 x 200 mm.

Length of beams:	4000 mm
Longitudinal spacing:	2300 mm
Transverse spacing:	800 mm

Test load:	26.54 ton
Corresponding cargo weight:	13.27 ton
Payload	28.31 ton



The deflection of the transverse girders indicated in the figure below was measured before and after loading as well as after unloading.

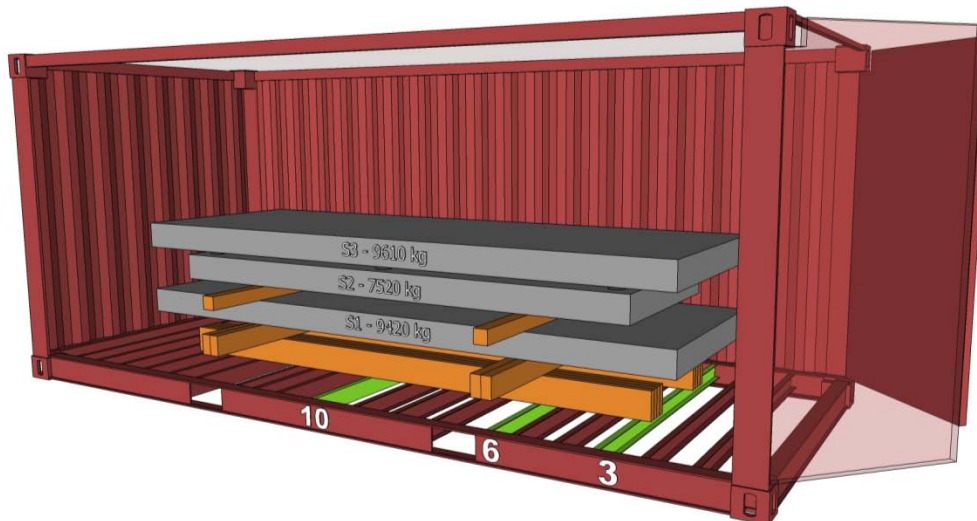

Set up for test of longitudinal bedding beams according to the German proposal. The deflection was measured for girders marked in green.

In the diagram below, the deflection of three girders has been plotted along with the theoretical deflection (based on a moment of inertia of 175 cm^4) for a freely supported beam. In the theoretic curves, it has been assumed that the load is uniformly distributed over 14 girders.

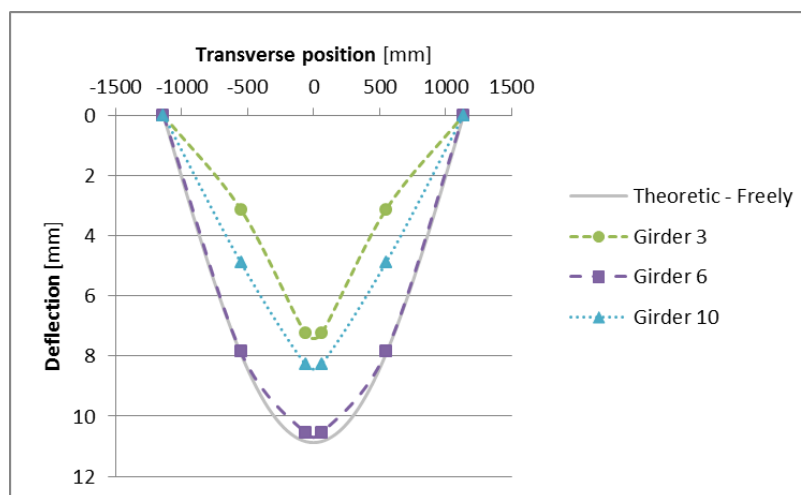

Deflection of girders relative to the side beams for a load of 26.55 tons

As can be seen in the diagram, the deflection of the girder directly underneath the load (Girder 6) corresponds very well to the theoretic deflection with the load distributed over all covered girders.

8.2 20' container – 150x150 mm

In this test the formulas in the Swedish proposal had been used to calculate the required dimensions of the longitudinal wooden beams:

$$n \cdot W = \frac{246 \cdot m \cdot (t - r)^2}{\sigma_{perm} \cdot t} \text{ cm}^3$$

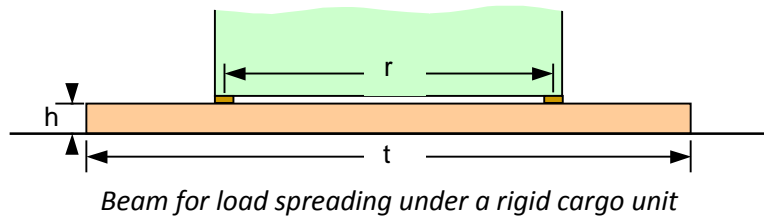

- W = section modulus of one beam [cm^3]
- n = number of parallel beams
- m = mass of cargo unit [t]
- t = length of beam [m]
- r = loaded length of beam (footprint) or bridging distance [m]
- σ_{perm} = permissible bending stress in beam [kN/cm^2]

The required length was 4 meters and the cross section was 150 x 150 mm.

Length of beams:	4000 mm
Longitudinal spacing:	2300 mm
Transverse spacing:	800 mm
Test load:	26.54 ton
Corresponding cargo weight:	13.27 ton
Payload	28.31 ton



The deflection of the transverse girders indicated in the figure below was measured before and after loading as well as after unloading.

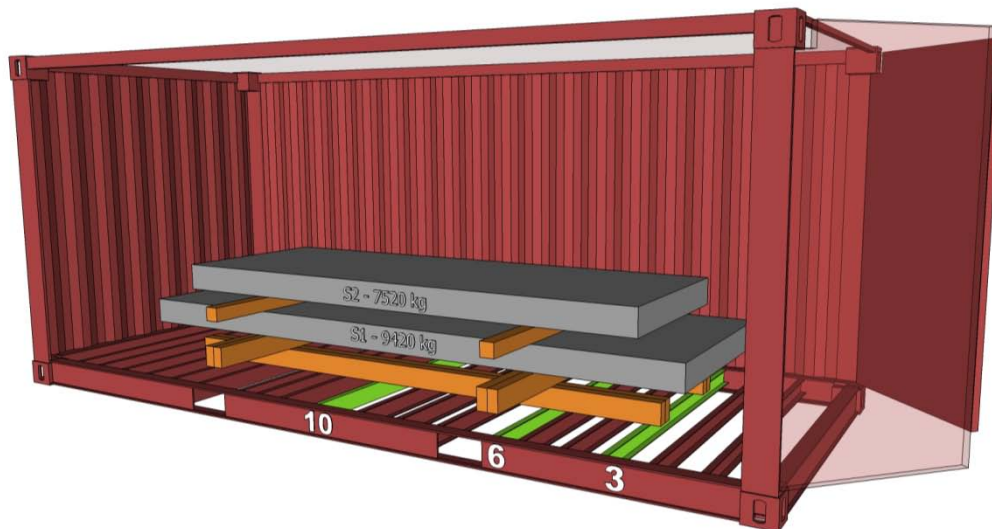

Set up for test of longitudinal bedding beams according to the Swedish proposal. The deflection was measured for girders marked in green.

In the diagram below, the deflection of three girders has been plotted along with the theoretical deflection (based on a moment of inertia of 175 cm^4) for a freely supported beam. In the theoretic curves, it has been assumed that the load is uniformly distributed over 14 girders.

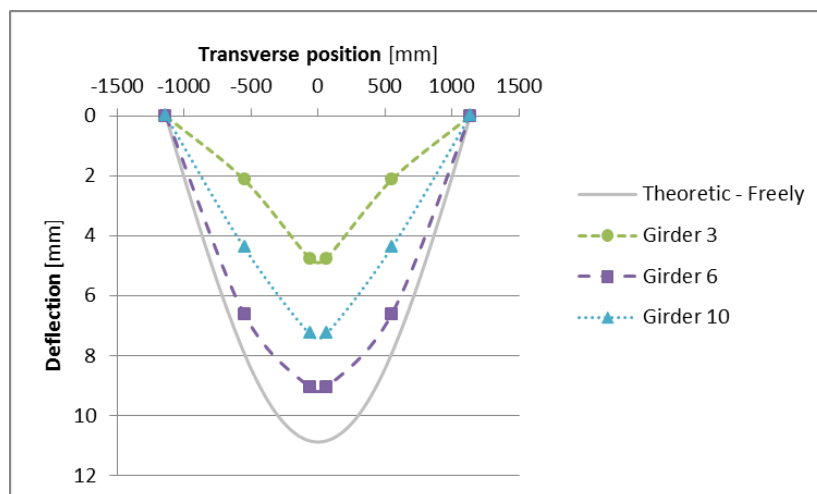

Deflection of girders relative to the side beams for a load of 26.54 tons

As can be seen in the diagrams above, the deflection of the girder directly underneath the load (Girder 6) corresponds fairly well to the theoretic deflection with the load distributed over all covered girders.

8.3 Conclusions

In none of the tests of the longitudinal bedding beams there were any signs of permanent deformation. Thus, both proposed methods can safely be applied.

The girders directly underneath the support points show the greatest deflection. For both the Swedish and the German proposal, this deflection corresponds very well to the expected deflection of the girders had the load been uniformly distributed over the full length of the longitudinal beams.

The girders near the end of the load (girder 3) show less deflection than the girder at the centre of the container (girder 10), although it is located closer to the most deflected girder (girder 6). This is likely to be due to a combination of the facts that the side beam twists less near the end of the container and that the longitudinal bedding beams are more effective in spreading the load towards the centre of the beams than towards the ends. This would not be the case if the longitudinal beams were cut in half at the centre. Regardless, the distance between the support points of the cargo should however not exceed 3 times the overhang of the longitudinal beams.

9 Test of transverse bedding beams

As an alternative to longitudinal bedding beams, the performance of transverse beams was also tested.

The dimensions of the beams were calculated according to the following formula, proposed by Sweden to the group of experts:

Where:

- W = Section modulus of support beams [cm^3]
 n = Number of support beams
 m = Cargo weight, [ton]
 s = Cargo width, [m]
 σ_p = Allowed stress in support beams, [kN/cm^2]
 l_e = Contributing length of container floor [m], taken as
 $l_e =$

9.1 20' container – 3 pcs 100x100 mm

Longitudinal spacing:	1500 mm
Transverse spacing:	1150 mm
Test load:	26.54 ton
Corresponding cargo weight:	13.27 ton
Payload	28.31 ton



In the first test, 3 transverse beams were placed directly on top of the 3 floor girders.

The deflection of the transverse girder indicated in the figure below was measured before and after loading as well as after unloading.

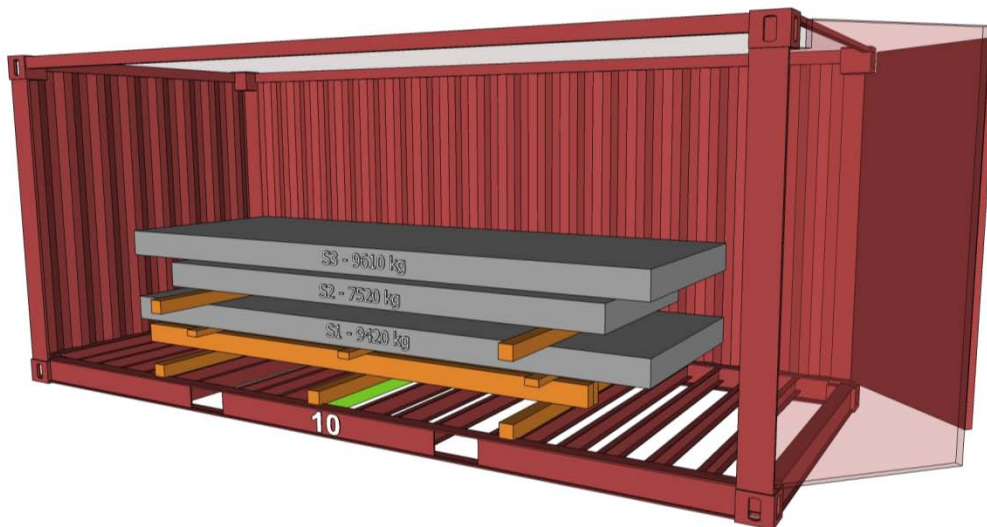

Set up for test of transverse bedding beams according to the Swedish proposal. Weight of test load 26.54 ton. The deflection was measured for girders marked in green.

In the diagram below, the deflection of the central girder has been plotted along with the theoretical deflection (based on a moment of inertia of 175 cm^4) for a freely supported beam loaded with a weight corresponding to 1/3 of the test load on each transverse wooden beam.

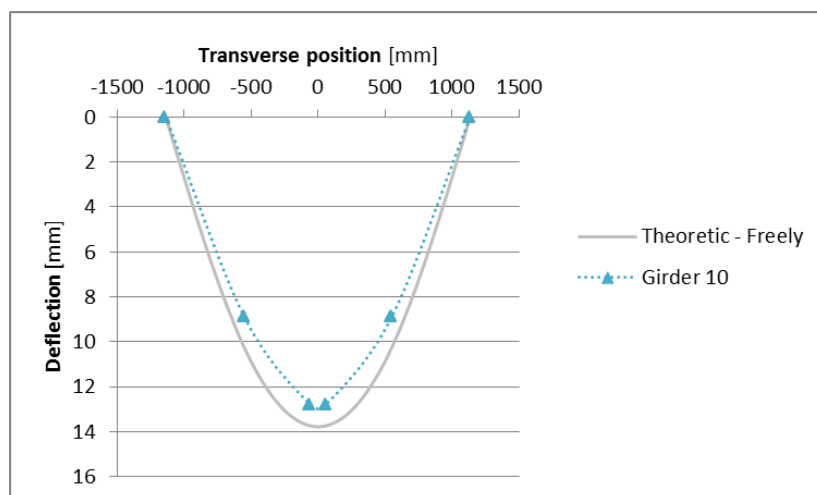

Deflection of girders relative to the side beams for a test load of 26.54 tons

The deflection of the central girder (Girder 10) is slightly less than the theoretic deflection, which indicates that the beams help spreading the load towards the sides.

9.2 20' container – 2 pcs 125x125 mm

Longitudinal spacing:	2000 mm
Transverse spacing:	1350 mm
Test load:	26.54 ton
Corresponding cargo weight:	13.27 ton
Payload	28.31 ton



In the second test 2 transverse beams were placed in-between two pairs of floor girders.

The deflection of the transverse girders indicated in the figure below was measured before and after loading as well as after unloading.

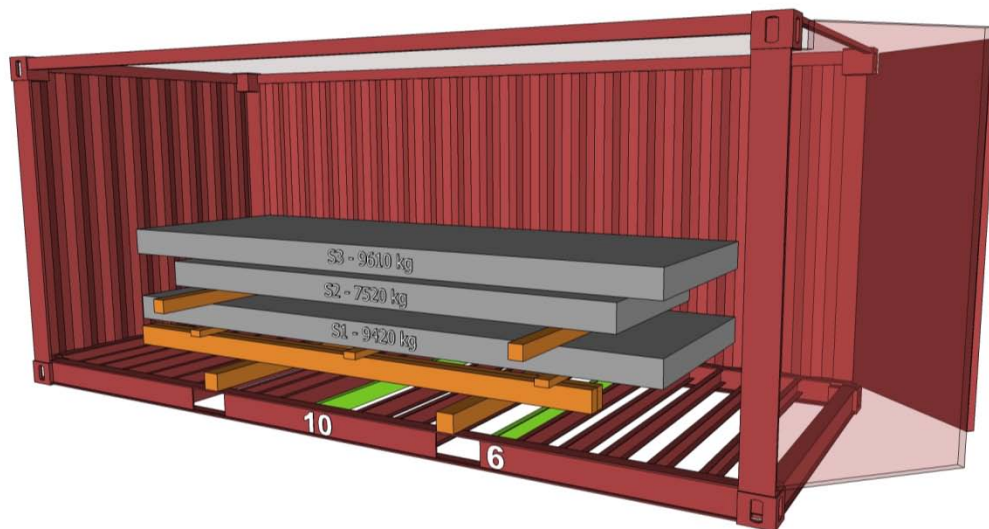

Set up for test of transverse bedding beams according to the Swedish proposal. Weight of load 26.54 ton. The deflection was measured for girders marked in green.

In the diagram below, the deflection of two girders has been plotted along with the theoretical deflection (based on a moment of inertia of 175 cm^4) for a freely supported beam loaded with a weight corresponding to 1/3 of the test load on each transverse wooden beam.

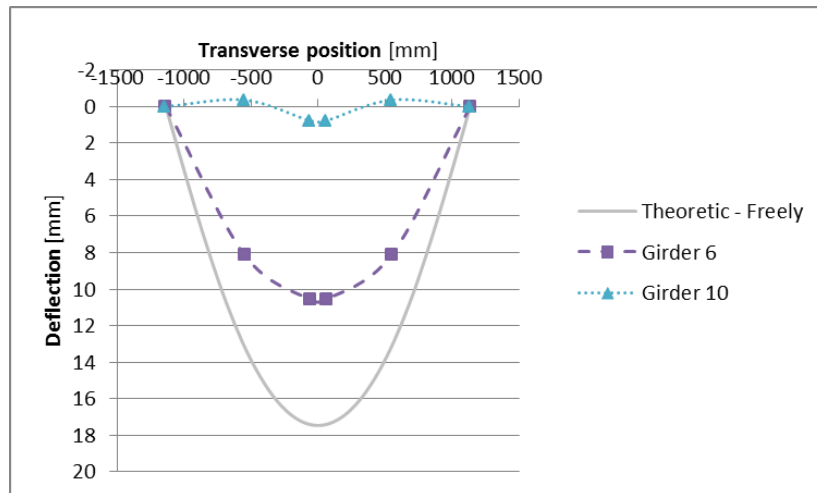

Deflection of girders relative to the side beams for a test load of 26.54 tons

The deflection of the girder closest to the bedding beam (Girder 6) is significantly less than the theoretic deflection, which indicates that the beams help spreading the load towards the sides rather efficiently.

9.3 Conclusions

In none of the tests of the transverse bedding beams there were any sign of permanent deformation and it can be concluded that in both cases the formula proposed by Sweden produced safe bedding arrangements.

It was noted during the tests that not only the girder directly underneath the transverse beams was engaged. However, the measurement of beam 10 (in the centre of the container) in the second test shows that the contribution from a girder 4 girders away from the loaded girder is neglectible.

10 Test of specific cradle designs for coils

The tests with specific cradle designs were conducted on April 4th and 5th in Avesta. Two designs were tested; a wooden cradle and the sledge that forms part of the Coil-Tainer concept. The designs are further described in chapter 3.4 above.

10.1 Wooden cradle

Length of load:	2000 mm
Width of load:	2300 mm
Weight of load:	40.03 ton
Corresponding cargo weight:	20.01 ton
Payload	28.31 ton



Two steel coils weighting approximately 20 ton each were loaded onto a wooden cradle which were placed at the centre of a 20' container.

The deflection of some selected girders relative the side beams are plotted in the diagram below, along with the theoretical deflection for a uniformly distributed load over the entire width of the 7 girders that are covered by the load.

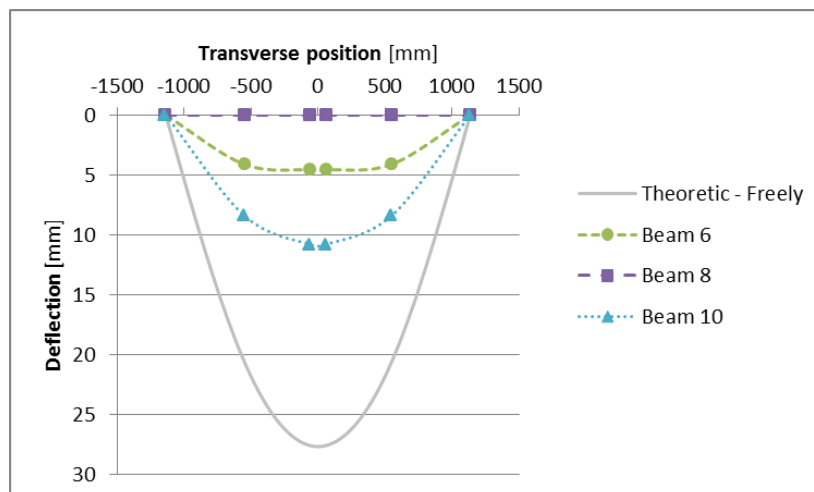

As can be seen in the diagram above, the deflection of the girders is much less than the theoretical deflection, which means that the cradle is rather effective in spreading the load towards the sides.

The maximum deflection of the side beams was approximately 4 mm, which corresponds well with the results from the test of longitudinal strength described in chapter 4 above.

10.2 Coil-Tainer

Length of load:	3000 mm
Width of load:	2300 mm
Weight of load:	42.15 ton
Corresponding cargo weight:	21.07 ton
Payload	28.31 ton



The Coil-Tainer arrangement was tested by loading 42 tons of steel slabs onto the sledge, that would otherwise hold a cradle for coils. The deflection of the centre girder relative the side beams are plotted in the diagram below, along with the theoretical deflection for a uniformly distributed load over the entire width of the 9 girders that are covered by the load.

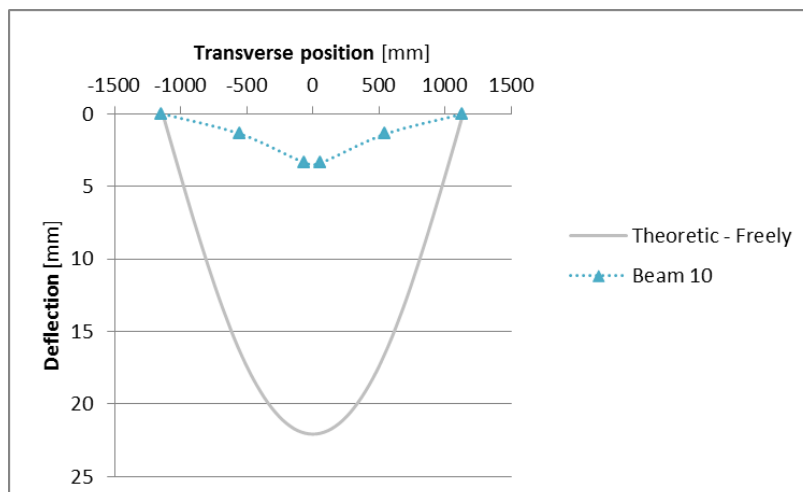

As can be seen in diagram above, the deflection of the girder is minimal and the beams in the Coil-Tainer are taking most of the load. The maximum deflection of the side beams was approximately 5 mm, which corresponds well with the results from the test of longitudinal strength described in chapter 4 above.

Appendix 1 – Containers

Containers used in tests in Avesta

10.2.1 20' container – 22G1

Main parameters

Serial number	MRKU 915243-5
Owner	MAERSK
Manufactured type	CB22-30-02
Manufacturer	CIMC QINGDAO
Size and type code	22G1
Year of manufacture	07/2012
Internal length	5900 mm
Internal width	2352 mm
Internal height	2393 mm
Maximum gross mass	30480 kg
Tare	2170 kg
Maximum payload	28310 kg
Internal volume	33,2 m ³

Floor cross members (transverse girders)

In total: 19 pcs

17 cross members – C profile – 2290x122x45x45x4 mm (numbered from doors as 1-8, 10-17, 19)

2 cross members – C profile – 2290x122x75x45x4 mm (numbered from doors as 9, 18) used as plywood boards connections

7 cross members between fork-lift pockets and 6 outside fork-lift pockets



Distance of cross members from door bottom corner castings (outer surface) to the centre of cross member

5700 mm between corner castings

280, 585, 880, 1140, 1400, 1600, 2015, 2330, 2650, 2970, 3285, 3505, 3685, 4085, 4370, 4650, 4930, 5210, 5455 mm

Bottom side rail

2 longitudinal beams – 155x50x30x30x4,5 mm

Outer bottom transverse distance: 2320 mm

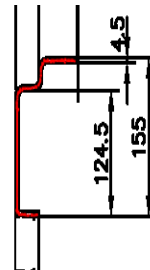

40' high-cube container – 45G1

Main parameters

Serial number	TGHU 803924-3
Owner	TEXTAINER
Manufactured type	SACI-1AH-22
Manufacturer	SUZHOU ASIA CONTAINER INTL CO., CHINA
Size and type code	45G1
Year of manufacture	11/2002
Internal length	12033 mm
Internal width	2352 mm
Internal height	2694 mm
Maximum gross mass	30480 kg
Tare	3850 kg
Maximum payload	26630 kg
Internal volume	76,24 m ³

Floor cross members (transverse girders)

In total: 29 pcs + 2x8 (gooseneck tunnel)

27 cross members – C profile – 2360x122x60x30x4,5 mm (numbered from doors as 1-12, 14-28)

2 cross members – C profile – 2360x122x60x30x4,5 mm (numbered from doors as 13, 29) used as plywood boards connections

Gooseneck tunnel cross members – C profile – 122x60x30x4,5 mm (numbered from doors as 30-37)

Distance of selected cross members from door bottom corner castings (outer surface) used during tests	215, 520, 810, 1120, 1405, 1720, 2015, 2315, 2615, 2920, 3220, 3520, 3810, 4115, 4405, 4715 mm
--	--

Bottom side rail

2 longitudinal beams – 158 x 50 x 30 x 4,5 mm

Outer bottom transverse distance: 2420 mm

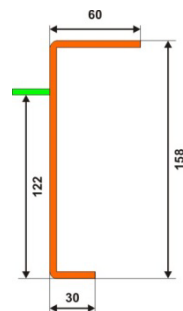

Containers used in tests in Helsingborg

20' container – 22G1

Main parameters

Serial number	CRXU 312110-7
Owner	CRONOS
Manufactured type	NOC2-49-01
Manufacturer	TIANJIN CIMC
Size and type code	22G1
Year of manufacture	07/2004
Internal length	5900 mm
Internal width	2352 mm
Internal height	2393 mm
Maximum gross mass	30 480 kg
Tare	2 250 kg
Maximum payload	28 230 kg
Internal volume	33,2 m ³

Floor cross members

In total: 19 pcs

17 cross members – C profile – 2290x122x45x45x4 mm

2 cross members – C profile – 2290x122x75x45x4 mm, used as plywood boards connections

7 cross members between fork-lift pockets and 6 outside fork-lift pockets

Bottom side rail

2 longitudinal beams – 155x50x30x30x4,5 mm

Outer bottom transverse distance: 2320 mm

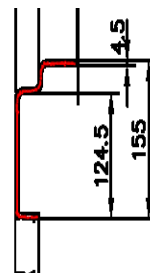

40' high-cube container – 45G1

Parameters of 45G1 container used in tests in Helsingborg

Serial number	CRXU 983868-8
Owner	CRONOS
Manufactured type	NOCAH-49-02
Manufacturer	TIANJIN CIMC
Size and type code	45G1
Year of manufacture	08-2004
Internal length	12033 mm
Internal width	2352 mm
Internal height	2694 mm
Maximum gross mass	32 500 kg
Tare	3 900 kg
Maximum payload	28 600 kg
Internal volume	76,40 m ³

Bottom side rail

2 longitudinal beams – 158 x 50 x 30 x 4,5 mm

Outer bottom transverse distance: 2420 mm

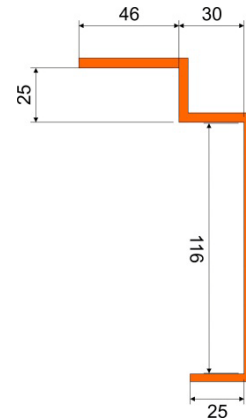

Appendix 2 – Cargo

Steel slabs (Avesta)

Five stainless-steel slabs of following dimensions and masses were used during the tests in Avesta.

Slab	Length [mm]	Width [mm]	Height [mm]	Mass [kg]	Total mass for tests 1.1, 1.2, 1.3, 2.1, 2.2, 3.1, 3.2	Total mass for fork-lift tests 6.1, 7.1	Total mass for coilcontainer test 5.1
S1	4470	1410	185	9420	26550 kg		41750 kg
S2	3820	1295	195	7520			
S3	4475	1450	195	9610			
S4	4475	1450	195	9600	15200 kg		
S5	3400	1088	195	5600			



Steel slabs of various weights

Steel coils (Avesta)

Coil	Diameter [mm]	Height [mm]	Mass [kg]	Total mass for test 4.1
C1	1900	1250	19940	40580 kg
C2	1900	1250	20640	



Steel coils

Lead ingots (Helsingborg)

Length [mm]	Width [mm]	Height [mm]	Mass avg. [kg]
600	600	350	1075



Bundles of lead ingots, weighing approx. 1 075 kg each