

Proposal for amendments to ECE/TRANS/WP.29/GRSP/2012/21

Proposal for Supplement 7 to the 04 series of amendments

The text reproduced below was prepared by the expert from the France on behalf of the Technical Services Group (TSG) on UN Regulation No. 44. It aims to clarify the lap strap interaction with the dummy and its assessment as well as improving the overturning test procedure in light of recent findings. The modifications to the current text of the UN Regulation are marked in bold for new or strikethrough for deleted characters.

I. Proposal

Contents, list of Annexes,

Insert a new Annex 23, to read:

"Annex 23 - Load application device"

Text of the Regulation,

Paragraph 2.8.1., amend to read:

2.8.1. "lap strap" means a strap which, either in the form of a complete belt or in the form of a component of such a belt, passes across the front of, and restrains, **directly or not**, the child's ~~pelvic region~~ **pelvis**;

Paragraph 6.2.1.5., amend to read:

"6.2.1.5. **For all forward-facing group I restraints incorporating an integral harness belt system** to prevent submarining, either by impact or through restlessness, a crotch strap shall be required. ~~on all forward-facing group I restraints incorporating an integral harness belt system. With the crotch strap attached, and in its longest position if adjustable, it shall not be possible to adjust the lap strap to lie above the pelvis in either the 9 kg or the 15 kg dummy.~~"

Paragraph 6.2.2., amend to read:

"6.2.2. For groups I, II and III, all restraint devices utilizing a "lap strap" must positively guide the "lap strap" to ensure that the loads transmitted by the "lap strap" are transmitted through the pelvis. **The assembly shall not subject weak parts of the child's body (abdomen, crotch, etc.) to excessive stresses.**"

Insert new paragraphs 6.2.2.1. and 6.2.2.2., to read:

"6.2.2.1. **With the crotch strap attached, and in its longest position if adjustable, it shall not be possible to adjust the lap strap to lie above the pelvis of both the smallest and largest dummy within the mass groups covered by the**

approval. For all forward-facing restraints, it shall not be possible to adjust the lap strap to lie above the pelvis of both the smallest and largest dummy within the mass groups covered by the approval."

- 6.2.2.2. During the dynamic test, as prescribed in paragraph 8.1.3., the lap belt shall not ~~wholly~~ pass **fully** beyond ~~or move over~~ the pelvic structure of the dummy, during the period prior to maximum horizontal head excursion. Assessment shall be carried out using high speed ~~camera video imaging-~~."

Paragraph 6.2.4., amend to read

- "6.2.4. ~~The assembly shall not subject weak parts of the child's body (abdomen, erotch, etc.) to excessive stresses. The design shall be such that compression loads shall not be imposed on the crown of the child's head in the event of a collision.~~"

Paragraph 7.1.3.1., amend to read

- "7.1.3.1. The child restraint shall be tested as prescribed in paragraph 8.1.2.; **at no point the manikin shall not fall out of the device during the whole test shall the manikin be fully ejected from the device and, in addition** when the test seat is in the upside down position the manikin's head shall not move more than 300 mm from its original position in a vertical direction relative to the test seat."

Paragraph 8.1.2.1., amend to read:

- "8.1.2.1. The manikin shall be equipped with the load application device as described in Annex 23 and placed in the restraints installed in accordance with this Regulation and taking into account the manufacturer's instructions and with the standard slack as specified in paragraph 8.1.3.6. below, **applied for all systems identically.**"

Paragraph 8.1.2.2., amend to read:

- "8.1.2.2. The restraint shall be fastened to the test seat or vehicle seat. The whole seat shall be rotated around a horizontal axis, contained in the median longitudinal plane of the seat through an angle of ~~360~~ **540°** +/- 5° at a speed of 2-5 degrees/second **and stopped in this position.** For the purposes of this test, devices intended for use in specific cars may be attached to the test seat described in Annex 6."

Insert new paragraphs 8.1.2.3. to 8.1.2.5., to read:

- "**8.1.2.3. At this static inverted position a total mass equivalent to ~~[5]~~ 4 times that of the dummy shall be applied vertically downwards in a plane perpendicular to the axis of rotation in addition to the dummy utilizing the load application device described in Annex 23. The load shall be applied in a gradual controlled manner at a rate not exceeding ~~[400 mm/min]~~ gravitational acceleration or 400mm/min. Maintain the prescribed maximum load for a duration of ~~[30-0/+5]~~ 30 -0/+5 seconds.**

- 8.1.2.4. Remove the load at a rate not exceeding ~~[400]~~ 400 mm/min and measure displacement.**

- 8.1.2.5. Rotate the whole seat for 180° to return to the starting position."**

Paragraph 8.1.2.3.and 8.1.2.4. (former), renumber as paragraphs 8.1.2.6. and 8.1.2.7. and amend to read:

"8.1.2.36. This test **cycle** shall be carried out again rotating in the reverse direction. ~~after having replaced, if necessary, the manikin in its initial position.~~ With the rotational axis in the horizontal plane and at 90° to that of the two earlier tests, the procedure shall be repeated in the two directions of rotation.

8.1.2.47. These tests shall be carried out using both the smallest and the largest appropriate manikin of the group or groups for which the restraining device is intended.

Any adjustment of the dummy or child restraint systems during the complete test cycle is not allowed."

Insert a new Annex 23, to read:

"Annex 23

Load application device I (to be used for Group 0 / 0+ products)

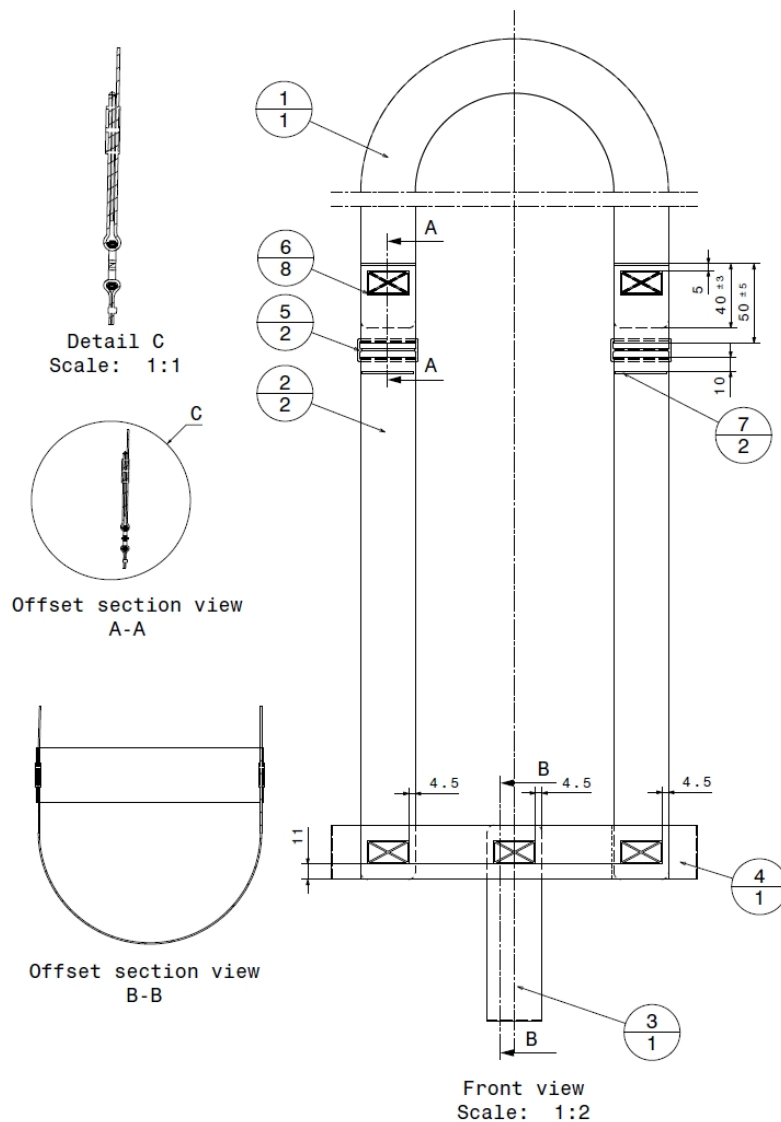

No.	Name	Information	Quantity
1	head belt - 39mm	-	1
2	shoulder belt lh/rh - 39mm	-	2
3	crotch belt - 39mm	-	1
4	hip belt - 39mm	-	1
5	stitch pattern (30x17)	stich: 77, thread: 30	8
6	plastic buckle	-	2
7	stitch pattern (2x37)	stich: 77, thread: 30	2

stretch lenght	(+/-5mm)					
	Dummy P/Q 0	Dummy P/3/4	P/Q 1,5	P/Q 3	P/Q 6	P/Q 10
head belt	1000mm	1000mm	1000mm	1200mm	1200mm	1200mm
shoulder belt	750mm	850mm	950mm	1000mm	1100mm	1300mm
crotch belt	300mm	350mm	400mm	400mm	450mm	570mm
hip belt	400mm	500mm	550mm	600mm	700mm	800mm
dimension X	120mm	130mm	140mm	140mm	150mm	160mm

stich pattern	min. required force
12x12mm	3,5 kN
30x12mm	5,3 kN
30x17mm	5,3 kN
30x30mm	7,0 kN

all belt radius = 5mm

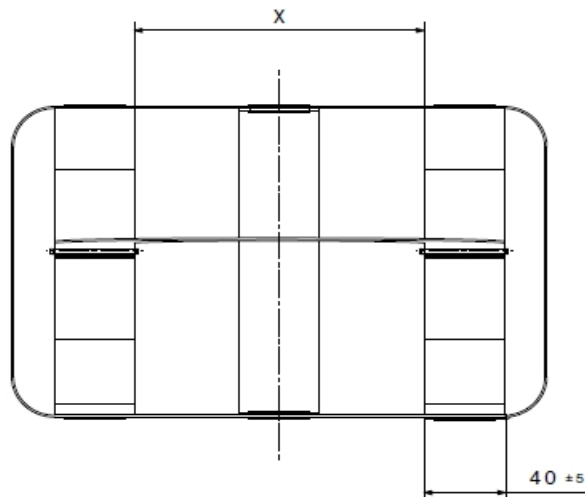

Top view
Scale:1:2



Isometric view
Scale:1:10

Load application device II (to be used for Group 1)

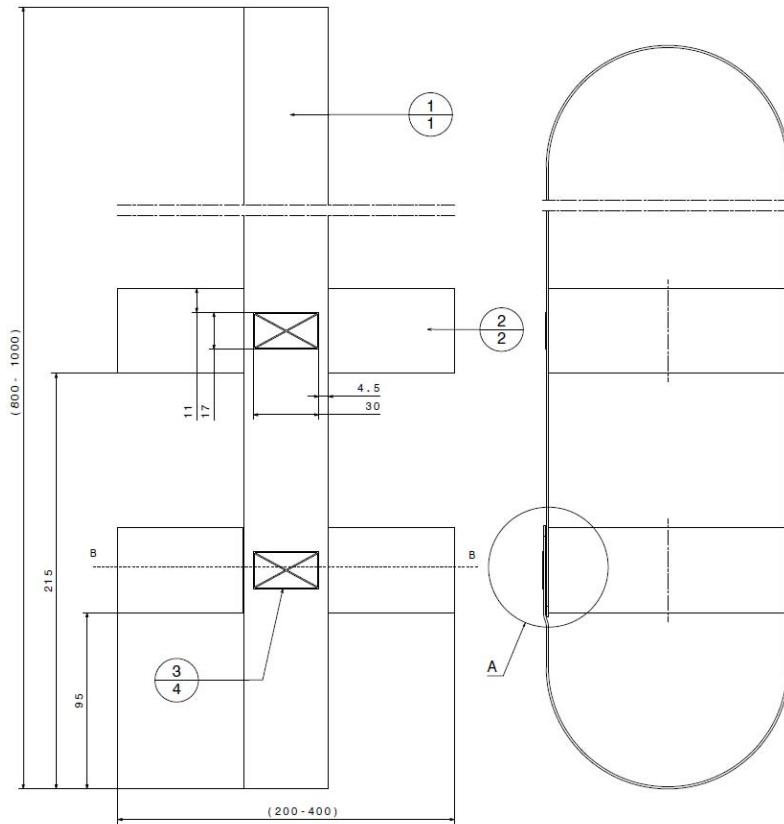

No.	Name	Information	Quantity
1	main belt - 39mm	-	1
2	hip belt (upper/lower) - 39mm	-	2
3	stitch pattern (30x17)	stich: 77, thread: 30	4

stretch length	(+/-5mm)					
	Dummy P/Q 0	Dummy P/S/4	P/Q 1,5	P/Q 3	P/Q 6	P/Q 10
main belt	1600mm	1600mm	1600mm	2000mm	2000mm	2000mm
hip belt	440mm	540	640mm	740mm	740mm	840mm

stich pattern	min. required force
12x12mm	3,5 kN
30x12mm	5,3 kN
30x17mm	5,3 kN
30x30mm	7,0 kN

all belt radius = 5mm

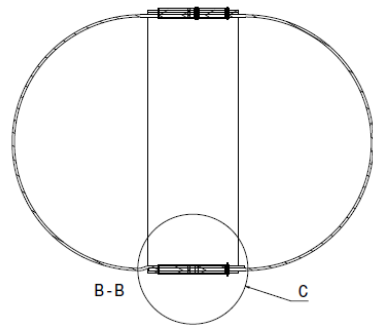
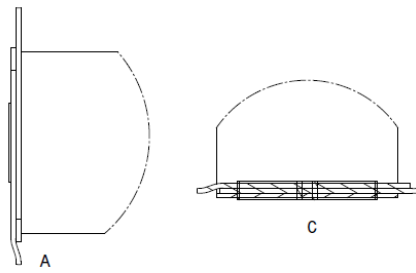

Top view
Scale:1:2

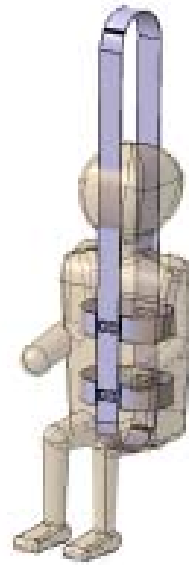

Isometric view
Scale:1:10

II. Justification

1. *Paragraph 2.8.1.:* Consistency with paragraph 6.2.2 and clarification of the meaning of "lap strap" in relation to devices used to restrain the child and ensure loading through the pelvis.
2. *Paragraph 6.2.1.5.:* Deals with submarining, while the second part of the paragraph covers requirement of lap strap position which is considered more relevant to paragraph 6.2.2. Assessment test method has been also clarified.
3. *Paragraph 6.2.2.:* Deals with effective lap belt positioning. Requirements about this item have been removed from 6.2.1.5 and 6.2.4 and collected in one paragraph. Due to complexity of the verification assessment, two subparagraphs have been prepared: 6.2.2.1 provides guidance for the static assessment of lap strap positioning, while 6.2.2.2 deals with dynamic assessment. Consequently also 6.2.4 has been modified.
4. *Paragraphs 7.1.3. to 8.1.2.7. and Annex 23:* The present test procedure does not adequately reflect the circumstances of real world rollover crashes. The procedure has been improved to reduce the existing differences between the test procedure and real accidents. A vertical quasi-static load is applied to simulate the dynamic behaviour of the child restraint systems and the dummy.