



**Economic and Social  
Council**

Distr.  
GENERAL

TRANS/WP.29/1003  
2 April 2004

ENGLISH  
Original: ENGLISH AND FRENCH

---

**ECONOMIC COMMISSION FOR EUROPE**

INLAND TRANSPORT COMMITTEE

World Forum for Harmonization of Vehicle Regulations (WP.29)

DRAFT SUPPLEMENT 7 TO THE 01 SERIES OF AMENDMENTS  
TO REGULATION No. 52

(Small capacity passenger vehicles, M2 and M3 category)

Note: The text reproduced below was adopted by the Administrative Committee (AC.1) of the amended 1958 Agreement at its twenty-sixth session, following the recommendation by WP.29 at its one-hundred-and-thirty-second session. It is based on document TRANS/WP.29/2004/21, not amended (TRANS/WP.29/992, para. 79).

---

Paragraph 5.6.2.5.2., amend to read (the reference to footnote 5/ and footnote 5/, should be deleted):

"5.6.2.5.2. The driver's door shall be accepted as the emergency door for the occupants of the seats situated beside the driver's seat provided that it is possible to move a test gauge from the occupants' seats to the exterior of the vehicle through the driver's door (see annex 3, figure 21).

Verification of the access to the driver's door shall be subject to the requirements of paragraph 5.7.3.2., by using the test gauge having a dimension of 600x400 mm, as described in paragraph 5.7.3.3. The service door provided for the passengers shall be in the side of the vehicle opposite to that containing the driver's door and shall be accepted as the emergency door for the driver;"

Paragraph 5.7.2.4.2., amend to read:

" ..... indicated in paragraph 5.6.2.5.2 and that the space reserved for the driver's seat shall communicate with the main passengers' compartment through an appropriate passage; such requirement shall be deemed to be fulfilled if the test gauge described in paragraph 5.7.5.1. can move unobstructed from the gangway, until the front end of the gauge reaches the vertical plane tangential to the foremost point of the driver's seat back (this seat situated in its rearmost longitudinal position) and, from this plane, the panel described in paragraph 5.6.2.5.2. could be moved to the emergency door in the direction established by such paragraph (see annex 3, figure 22) with seat and steering wheel adjustment in their mid position."

Paragraph 5.7.8.5.1., amend to read:

"5.7.8.5.1. For a seat behind a partition or other rigid structure other than a seat, a minimum clear space in front of each passenger seat shall be provided as shown in annex 3, figure 16. A partition whose contour corresponds approximately to that of the inclined seat back may intrude into this space as provided by paragraph 5.7.8.4. Intrusion of the dashboard, instrument panel, windscreen, sun visor, seat belts anchorages shall be allowed."

Insert a new paragraph 5.7.8.5.2., to read:

"5.7.8.5.2. For a seat behind a seat and/or a seat facing the gangway, a minimum clear foot space of at least 300 mm depth and a width according to paragraph 5.7.8.2.1. shall be provided as shown in annex 3, figure 15b. The local presence in this space of seat legs and of intrusions as provided by paragraphs 5.7.8.1.3.3. and 5.7.8.1.3.4. shall be permitted provided that adequate space remains for the passengers' feet. This foot space may partly be situated in and/or above the gangway but shall not create any obstruction when measuring the minimum gangway-width in accordance with paragraph 5.7.5. Intrusion of the seat belts and seat belt anchorages shall be allowed."

Paragraph 5.7.8.5.2., renumber as paragraph 5.7.8.5.3.

Annex 3,

Figure 15, renumber as Figure 15a.

Insert a new figure 15b, to read:

"Figure 15b

SPACE FOR SEATED PASSENGERS BEHIND A SEAT AND/ OR A SEAT FACING THE  
GANGWAY  
(see paragraph 5.7.8.5.2)

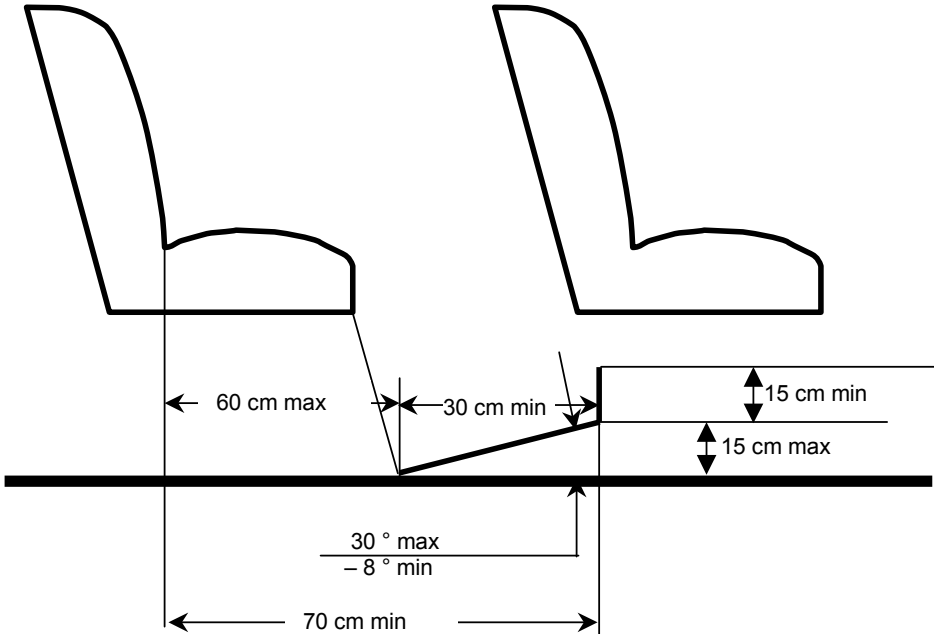

"

Figure 16, amend the title to read:

"Figure 16

SPACE FOR SEATED PASSENGERS BEHIND A PARTITION OR OTHER RIGID  
STRUCTURE OTHER THAN A SEAT  
(see paragraph 5.7.8.5.1)"

Insert new figures 21 and 22, to read:

“Figure 21  
**ACCESS TO DRIVER’S DOOR**  
(See paragraph 5.6.2.5.2.)

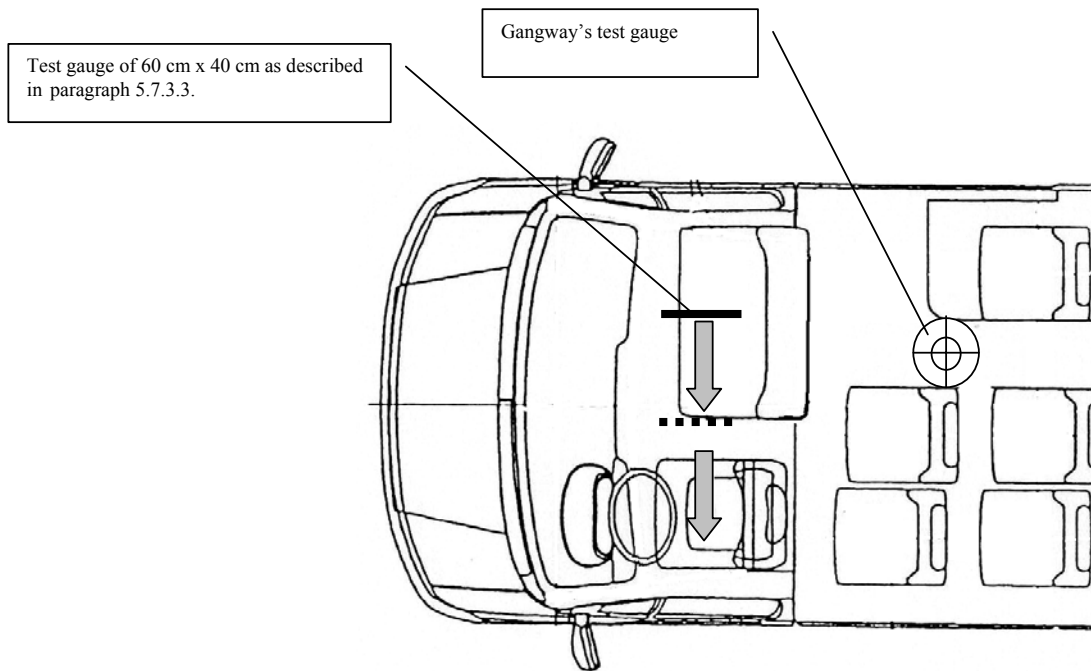
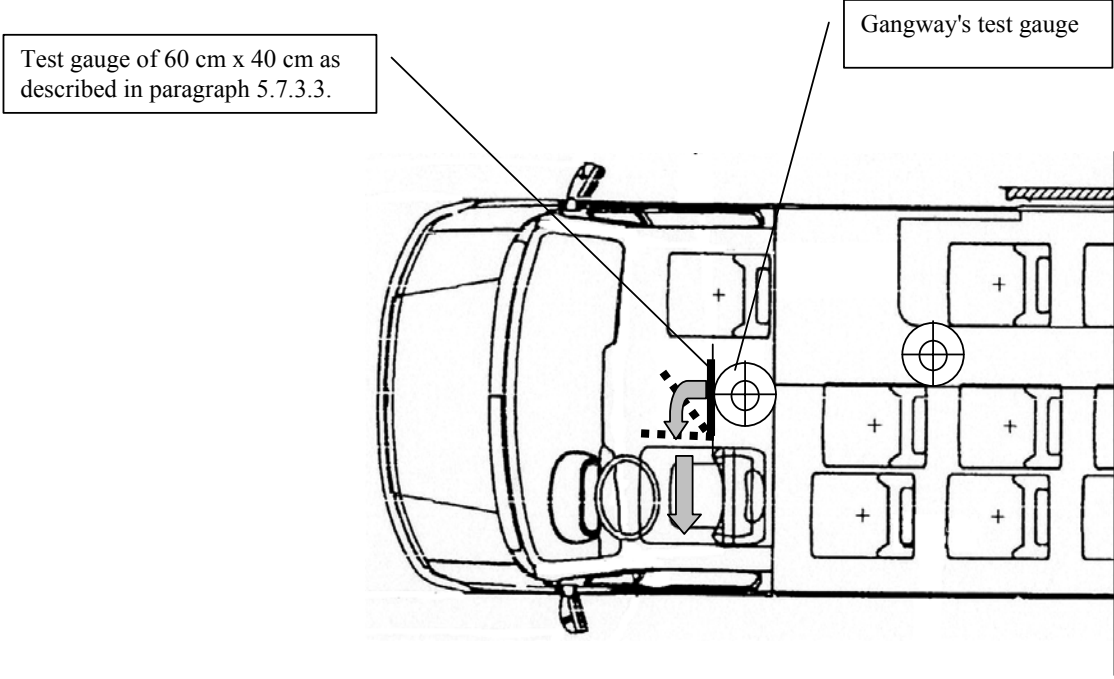

Figure 22  
**ACCESS TO DRIVER'S DOOR**  
(See paragraph 5.7.2.4.2.)



"