

**Economic and Social Council**Distr.: General  
5 March 2010Original: English  
English and French only

---

**Economic Commission for Europe**

Inland Transport Committee

**World Forum for Harmonization of Vehicle Regulations**

Working Party on Passive Safety

**Forty-seventh session**

Geneva, 17–21 May 2010

Item 4.1 of the provisional agenda

**Global technical regulation No. 9 (Pedestrian safety) – Phase 2  
of the global technical regulation  
(flexible legform impactor provisions)****Proposal for amendments to global technical regulation No. 9****Submitted by the expert from Japan\***

The text reproduced below was prepared by the expert from Japan in order to propose the use of the Flexible Pedestrian Legform Impactor (FlexPLI) in the global technical regulation (gtr) No. 9 (pedestrian safety). It is based on ECE/TRANS/WP.29/GRSP/2009/21 and on a document without symbol (GRSP-46-17/Rev.1) distributed during the forty-sixth session of the Working Party on Passive Safety (GRSP). The modifications to the current text of the gtr No. 9 on pedestrian safety are marked in bold or strikethrough characters.

---

\* In accordance with the programme of work of the Inland Transport Committee for 2006–2010 (ECE/TRANS/166/Add.1, programme activity 02.4), the World Forum will develop, harmonize and update Regulations in order to enhance the performance of vehicles. The present document is submitted in conformity with that mandate.

## I. Proposal

### A. Statement of technical rationale and justification

*Paragraph 64.*, amend to read:

“64. The lower legform...in the United Kingdom, **and then called as EEVC WG17 pedestrian lower legform impactor**. However, it is known to also have certain limitations regarding the biofidelity and the repeatability of the test results. Therefore, Japan proposed to use a completely new legform, the so-called Flexible Pedestrian Legform Impactor (FlexPLI). As the FlexPLI legform is considered by some to have high biofidelity and an excellent ability to assess potential leg injuries, the FlexPLI should be considered to replace **EEVC WG17 pedestrian** lower legform impactor in the future. However, because of the lack of experience in using the FlexPLI as a certification tool, a further confirmation process is needed. Therefore, a Technical Evaluation Group (TEG) was established to evaluate the reliability of the FlexPLI as a certification tool (TRANS/WP.29/GRSP/36). The TEG is currently assessing the FlexPLI and will advise GRSP by the end of 2007 as to the suitability of the FlexPLI for testing and compliance verification purposes (TRANS/WP.29/GRSP/37). The TEG is also expected to provide its recommendation as to the effective date of entry into force and the date on which the FlexPLI could replace the rigid lower legform impactor. **The TEG will also consider a transitional period during which the FlexPLI and the rigid lower legform impactor can be used as alternatives. Several years have passed since then, and the TEG finalized their technical evaluation on the FlexPLI by a majority of its members in 2009. Therefore, this gtr also includes the FlexPLI requirements as well as the EEVC WG17 pedestrian lower legform impactor requirements.**”

*Paragraph 102.*, amend to read:

“102. For vehicles....Therefore, the group recommends to use the upper legform to bumper test as an optional alternative to the lower legform to bumper test for these vehicles. **The test methods for high bumper vehicles can be applied not only when using the EEVC WG17 pedestrian lower legform impactor but also when using the FlexPLI.**”

*Paragraph 106.*, amend to read:

“106. It was agreed....However, it was also recommended to consider the possible future use of the Flex-PLI, which is considered by some to be more biofidelic and expected to be highly usable and repeatable, following the evaluation to be conducted by the Technical Evaluation Group (TEG) (INF GR/PS/106). 19/ **Several years have passed, and the TEG finalized their technical evaluation on the FlexPLI by a majority of its members in 2009. Therefore, this gtr also includes the FlexPLI requirements as well as the EEVC WG17, pedestrian lower legform impactor requirements.**”

*Paragraph 110.*, amend to read:

“110. These studies....For these reasons, a bending limit of 19° **for the EEVC WG17 pedestrian lower legform** was selected for this gtr. **As for the Flex-PLI, a limit of medial collateral ligament (MCL) elongation at the knee was set at 22 mm based on the agreement of the TEG from a biomechanical point of view (based on Bundesanstalt fuer Strassenwesen (BASt – German Federal Highway Research Institute) correlation study and Japan Automobile Manufacturers Association (JAMA) biomechanical study).**”

*Paragraph 111.*, amend to read:

“111. With regard to knee shearing limits, the informal group selected a limit of 6 mm **for the EEVC WG 17 pedestrian lower legform impactor**, based on the analysis of PMHS by EEVC WG17 and WG10 that showed that a 6 mm shear displacement corresponds to a 4 kN shear force. The 4 kN shear force in the TRL device approximates the 3 kN average peak shearing force acting at the knee joint level that was found associated in the PMHS tests with diaphysis/metaphysis failure. **As for the FlexPLI, a limit of anterior cruciate ligament (ACL) elongation and a limit of posterior cruciate ligament (PCL) elongation at the knee are both set as [ (1) [13] mm only for monitoring purposes or nothing because the percentage of isolated ACL/PCL damage in car-pedestrian accidents is very small (3 per cent). Besides only two biomechanical data are available for the ACL/PCL threshold values (JAMA and ACEA opinion), or (2) 13 mm as mandatory threshold value because the current gtr 9 sets shearing displacement requirement for the EEVC WG17 pedestrian legform impactor and because of existing though limited biomechanical data (BAST opinion)].**”

*Paragraph 112.*, amend to read:

“112. With regard.....To protect a higher proportion of the population at risk, the informal group recommends a maximum lateral tibia acceleration limit of 170g **for the EEVC WG17 pedestrian lower legform impactor**. **As for the FlexPLI, the limit of tibia bending moment is set at 340 Nm based on the agreement of the TEG from a biomechanical point of view (based on BAST and JAMA biomechanical studies).**”

*Paragraph 113.*, amend to read:

“113. In summary...at the following limits:

**For EEVC WG 17 pedestrian lower legform impactor**

Maximum lateral knee bending angle  $\leq 19.0^\circ$ ;

Maximum lateral knee shearing displacement  $\leq 6.0$  mm;

Maximum lateral tibia acceleration  $\leq 170$ g.

**For FlexPLI**

**Maximum MCL elongation  $\leq 22$  mm;**

**Maximum Tibia bending moment  $\leq 340$  Nm;**

**[Maximum ACL and PCL elongation  $\leq [13]$  mm only for monitoring purposes or nothing or mandatory].**”

*Paragraph 114.*, amend to read:

“114. These values **for EEVC WG17 pedestrian lower legform impactor** are identical to those **that were** under consideration by the EC in its review of the Phase 2 requirements of the European directive.”

*Paragraph 115.*, amend to read:

“115. In order.....For feasibility reasons, this gtr allows manufacturers to nominate bumper test widths up to 264 mm in total where the acceleration measured at the upper end of the tibia **of the EEVC WG 17 pedestrian lower legform impactor** shall not exceed 250g. The relaxation zone of 264 mm corresponds to an area that is twice the width of the legform. **[As for the FlexPLI, for feasibility reasons, the TEG proposed to allow manufacturers, if necessary, based on TEG technical feasibility study results, to**

nominate bumper test widths up to 264 mm in total where the tibia bending moment of the FlexPLI shall not exceed TBD Nm].”

*Insert a new section 10., to read:*

**“10. METHOD OF INTRODUCING THE FLEX-PLI**

[133. As for the introduction of the new lower legform impactor FlexPLI by each Contracting Party, the TEG provided the following recommendations:

- (a) Some TEG members proposed that the period for using alternative impactors of EEVC WG 17 pedestrian lower legform impactor or FlexPLI should end 96 months after the date of entry into force in the respective national legislation for each contracting party.
- (b) Some TEG members also propose that a vehicle model once certified using the EEVC WG 17 pedestrian legform impactor does not need to be re-certified using the FlexPLI.]”

*Section 10 (former), renumber as section 11 and amend to read:*

**“11. APPENDIX–REFERENCE DOCUMENTS USED BY THE WORKING GROUP**

...	...
INF GR/PS/188	Draft meeting minutes of the 100th meeting
INF GR/PS/189	Attendance list 10th meeting

---

A list of working papers used by the FlexTEG group is listed and available on the UNECE WP.29 website:  
[http://www.unece.org/trans/main/wp29/wp29wgs/wp29grsp/pedestrian\\_FlexPLI.html](http://www.unece.org/trans/main/wp29/wp29wgs/wp29grsp/pedestrian_FlexPLI.html)

---

<i>Number of working paper</i>	<i>Title of Flex TEG document</i>
<b>TEG-001</b>	<b>Agenda for 1st Meeting of Flex PLI Technical Evaluation Group.doc</b>
<b>TEG-002</b>	<b>Flex-G_General_Information_050904.pdf</b>
<b>TEG-003</b>	<b>Flex-G_Preparation_Manual_050904.pdf</b>
<b>TEG-004</b>	<b>2005.09.02 - BAST Flex-G Test Programme.pdf</b>
<b>TEG-005</b>	<b>Revised Agenda for 1st Flex-G_MT.pdf</b>
<b>TEG-006</b>	<b>2005_06_ESV_JAMA-Flex.pdf</b>
<b>TEG-007</b>	<b>2005_06_ESV_JMLIT-Flex.pdf</b>
<b>TEG-008</b>	<b>2005_06_ESV_NHTSA_TRL-Flex.pdf</b>
<b>TEG-009</b>	<b>Attendance list 1<sup>st</sup> Flex-PLI Meeting</b>
<b>TEG-010</b>	<b>Draft minutes 1st Flex PLI meeting_051011.pdf</b>
<b>TEG-010-R1</b>	<b>Modified_Minutes 1st Flex PLI meeting_051122.pdf</b>
<b>TEG-011</b>	<b>Agenda for 2nd Meeting of Flex-TEG.pdf</b>

<i>Number of working paper</i>	<i>Title of Flex TEG document</i>
<b>TEG-011- R1</b>	<b>Modified_Agenda for 2nd Meeting of Flex-TEG.pdf</b>
<b>TEG-012</b>	<b>Flex-G_Minor_Modifications_onto_SN01_051122.pdf</b>
<b>TEG-013</b>	<b>Flex Repeatability and Reproducibility for Thigh Leg Knee.pdf</b>
<b>TEG-014</b>	<b>Flex_Assembly_Test_Results_and_Tentative_Corridors_051122.pdf</b>
<b>TEG-015</b>	<b>Report_on_Flex-G_Car_Test_Results_051122_final.pdf</b>
<b>TEG-016</b>	<b>Flex-TEG_Schedule_051115.pdf</b>
<b>TEG-016- R1</b>	<b>Flex-TEG_Schedule_051122.pdf</b>
<b>TEG-017</b>	<b>Attendance list 2nd Flex-PLI .pdf</b>
<b>TEG-018</b>	<b>DRAFT Minutes 2nd Flex-TEG_060228.pdf</b>
<b>TEG-018- R1</b>	<b>FINAL Minutes 2nd Flex-TEG_060424.pdf</b>
<b>TEG-019</b>	<b>Draft Agenda for 3rd Meeting of Flex-TEG_060327.pdf</b>
<b>TEG-020</b>	<b>Status Report on Action Items_060424.pdf</b>
<b>TEG-021</b>	<b>Flex-GT-alpha_General_Information_060424.pdf</b>
<b>TEG-022</b>	<b>Flex-GT-alpha_Injury_Assessment_Ability_060424.pdf</b>
<b>TEG-023</b>	<b>TRL-LFI_Retry_Test_060424.pdf</b>
<b>TEG-024</b>	<b>Flex-GT- alpha_Typical_Dynamic_Assembly_Calibration_Test_Result_060424.xls</b>
<b>TEG-025</b>	<b>Attendance list 3rd Flex-TEG_060424.pdf</b>
<b>TEG-026</b>	<b>DRAFT Minutes 3rd Flex-TEG</b>
<b>TEG-026- R1</b>	<b>Final_Minutes_3rd_Flex-TEG_MT_070402.pdf</b>
<b>TEG-027</b>	<b>ACEA_draft_comments_Flex-GT-alpha_060530.pdf</b>
<b>TEG-028</b>	<b>Chairperson_Answer_on_the_ACEA_draft_comments_Flex-GT- alpha_060606.pdf</b>
<b>TEG-029</b>	<b>Draft_Agenda_on_4th_Flex-TEG_Meeting_070316.pdf</b>
<b>TEG-029- R1</b>	<b>Final_Agenda_on_4th_Flex-TEG_Meeting_070402.pdf</b>
<b>TEG-030</b>	<b>Status_Report_on_Action_Items_070402.pdf</b>
<b>TEG-031</b>	<b>Development of an FE Biofidelic Flexible Pedestrian Legform Impactor Model (FLEX-GT-prototype Model)</b>

<i>Number of working paper</i>	<i>Title of Flex TEG document</i>
<b>TEG-032</b>	<b>Development of a Biofidelic Flexible Pedestrian Legform Impactor Type GT (FLEX-GT)</b>
<b>TEG-033</b>	<b>Information on Flexible Pedestrian Legform Impactor Type GT (FLEX-GT)</b>
<b>TEG-034</b>	<b>Flexible Pedestrian Legform Impactor Type GT (FLEX-GT) Evaluation Test Results</b>
<b>TEG-035</b>	<b>Flexible Pedestrian Legform Impactor Type GT (FLEX-GT) Car Test Results</b>
<b>TEG-036</b>	<b>Flex-GT-alpha BAST/ACEA Tests</b>
<b>TEG-037</b>	<b>Handling and Usage (Flex-GT-alpha)</b>
<b>TEG-038</b>	<b>Certification Histories (Flex-GT-alpha)</b>
<b>TEG-039</b>	<b>ACEA Preliminary Test Results with FlexPLI-alpha</b>
<b>TEG-040</b>	<b>Attendance list of 4th Flex-TEG meeting</b>
<b>TEG-041</b>	<b>Draft minutes of 4th Flex-TEG meeting</b>
<b>TEG-041-Rev.1</b>	<b>Finalized_the_4th_Flex-TEG_Meeting_Minutes_071207</b>
<b>TEG-042</b>	<b>FlexPLI Comments ACEA 20070808 TFP approved</b>
<b>TEG-043</b>	<b>ACEA/BAST Joint Project Report on Tests with the Flexible Pedestrian Legform Impactors Flex GT alpha and Flex GT</b>
<b>TEG-044</b>	<b>5th_Flex-TEG_Meeting_DRAFT_Agenda</b>
<b>TEG-044-Rev.1</b>	<b>Revised 5th Flex-TEG Meeting DRAFT Agenda_071204</b>
<b>TEG-044-Rev.2</b>	<b>Finalized 5th Flex-TEG Meeting Agenda 071207</b>
<b>TEG-045</b>	<b>J-MLIT Flex-GT Simplified Car Test Results 071129</b>
<b>TEG-045-Rev.1</b>	<b>J-MLIT Flex-GT Simplified Car Test Results 080331</b>
<b>TEG-046</b>	<b>JAMA-JARI Answer for the ACEA Comments Sep 2007 071129</b>
<b>TEG-047</b>	<b>Flex-GT Full Calibration Test Procedures 071129</b>
<b>TEG-048</b>	<b>Review of Injury Criteria and Thresholds for Flex 071129</b>
<b>TEG-049</b>	<b>Evaluation of Protection Level Provided by Flex-PLI 071129</b>
<b>TEG-050</b>	<b>Status of Action Items 071130</b>
<b>TEG-051</b>	<b>BAST/ACEA Joint Project Preliminary Report on Flex-GT Repeatability and Reproducibility of Assembly Certification and inverse</b>

<i>Number of working paper</i>	<i>Title of Flex TEG document</i>
<b>test results</b>	
<b>TEG-052</b>	<b>FTSS Design Review of Flex-GT and FLEX-GTR Development dec14-07</b>
<b>TEG-053</b>	<b>Draft Minutes of the 5th Flex-TEG Meeting, 080124</b>
<b>TEG-053- Rev.1</b>	<b>Final Minutes of the 5th Flex-TEG Meeting, 080331</b>
<b>TEG-054</b>	<b>Flex-GTR_Mechanical_Design_080229</b>
<b>TEG-054- Rev.1</b>	<b>Flex-GTR_Mechanical_Design_080331</b>
<b>TEG-055</b>	<b>Flex-GTR_Instrumentation_Electrical_Design_080229</b>
<b>TEG-055- Rev.1</b>	<b>Flex-GTR_Instrumentation_Electrical_Design_080331</b>
<b>TEG-056</b>	<b>Flex-GTR_Full_Calibration_Test_Procedure_080229</b>
<b>TEG-056- Rev.1</b>	<b>Flex-GTR_Full_Calibration_Test_Procedure_080331</b>
<b>TEG-057</b>	<b>Flex-GTR_Optional_Instrumentation_080304</b>
<b>TEG-057- Rev.1</b>	<b>Flex-GTR_Optional_Instrumentation_080327</b>
<b>TEG-058</b>	<b>M=BUS_Onboard_DAS_Information_080305</b>
<b>TEG-058- Rev.1</b>	<b>M=BUS_Onboard_DAS_Information_080331</b>
<b>TEG-059</b>	<b>Slice_Onboard_DAS_Information_080331</b>
<b>TEG-060</b>	<b>Draft_Agenda_6th_Flex-TEG_Meeting_080314</b>
<b>TEG-060- Rev.1</b>	<b>Final_Agenda_6th_Flex-TEG_Meeting_080331</b>
<b>TEG-061</b>	<b>Status of the Action Items_080331</b>
<b>TEG-062</b>	<b>BASt Proposal for a Full Assembly Certification Test_080331</b>
<b>TEG-063</b>	<b>NHTSA_Flex-GT_Test_summary_080331</b>
<b>TEG-064</b>	<b>NHTSA_Flex-GT_Certification_Tests_080331</b>
<b>TEG-065</b>	<b>NHTSA_Design_Upper_Body_Mass_080331</b>
<b>TEG-066</b>	<b>TIPS_for_Measurement_Cable_Repairment_080331</b>
<b>TEG-067</b>	<b>Repeatability_of_Dynamic_Assembly_Test_Stopper_Material_080331</b>
<b>TEG-068</b>	<b>Draft Minutes of the 6th Flex-TEG Meeting</b>

<i>Number of working paper</i>	<i>Title of Flex TEG document</i>
<b>TEG-068- Rev.1</b>	<b>Finalized_Minutes_of_the_6th_Flex-TEG_Meeting_081208</b>
<b>TEG-069</b>	<b>Draft_Agenda_7th_Flex-TEG_Meeting_081208</b>
<b>TEG-069- Rev.1</b>	<b>Finalized_Agenda_7th_Flex-TEG_Meeting_081208</b>
<b>TEG-070</b>	<b>Status_Action_Items_081208</b>
<b>TEG-070- Rev.1</b>	<b>Finalized_Status_Action_Items_081208</b>
<b>TEG-071</b>	<b>FTSS_Flex_GTR_prototype_Development_071208</b>
<b>TEG-071- Add.1</b>	<b>Bone_Core_Durability_Improvement_081208</b>
<b>TEG-071- Add.2</b>	<b>Develop_Dynamic_Assy_Calibration_Test_Methods</b>
<b>TEG-072</b>	<b>Japan_Flex-GTR-prototye_Evaluation_Report</b>
<b>TEG-072- Rev1</b>	<b>Japan_Flex-GTR-prototye_Evaluation_Test Result</b>
<b>TEG-073</b>	<b>MESSRING_ISO_MME_corde_Flex_Proposal</b>
<b>TEG-073- Rev1</b>	<b>MESSRING_Suggest_ISO_MME_corde_Flex</b>
<b>TEG-074</b>	<b>FTSS_Flex_Pendulum_Dynamic_Calbration_Proposal</b>
<b>TEG-075</b>	<b>BASSt_Flex_Inverse_Dynamic_Calibration_Proposal</b>
<b>TEG-076</b>	<b>JAMA_Proposal_MCL_Threshod_Value</b>
<b>TEG-077</b>	<b>JAMA_Proposal_Tibia_Threshod_Value</b>
<b>TEG-078</b>	<b>BASSt_Proposal_ACL-PCL-MCL_Threshod_Value</b>
<b>TEG-079</b>	<b>JAMA_Proposal_Flex-GTR-prot_Evaluation_Schedule</b>
<b>TEG-080</b>	<b>J-MLIT proposal for the Flex-TEG working schedule</b>
<b>TEG-081</b>	<b>JAMA_Flesh_Sensitivity_TRL_Flex</b>
<b>TEG-082</b>	<b>BASSt_Flesh_Sensitivity_TRL</b>
<b>TEG-083</b>	<b>Draft Minutes of the 7th Flex-TEG Meeting</b>
<b>TEG-083- Rev1</b>	<b>Finalized_Minutes_7th_Flex-TEG_Meeting</b>
<b>TEG-084</b>	<b>JAMA_Proposal_Tibia_Injury_Criteria</b>
<b>TEG-085</b>	<b>Draft_Agenda_8th_Flex-TEG_Meeting</b>



<i>Number of working paper</i>	<i>Title of Flex TEG document</i>
<b>TEG-085- Rev1</b>	<b>Finalized_Agenda_8th_Flex-TEG_Meeting</b>
<b>TEG-086</b>	<b>Draft_Status_Report_Action_Items</b>
<b>TEG-086- Rev1</b>	<b>Finalized_Status_Report_Action_Items</b>
<b>TEG-087</b>	<b>JAMA-JARI_L-R_Symetric_Bumper_Corner_Test_0903011</b>
<b>TEG-088</b>	<b>JAMA_Flex-GTR-proto_Round_Robin_Test</b>
<b>TEG-089</b>	<b>BASt_BGS_Flex_Test_Report</b>
<b>TEG-090</b>	<b>ACEA_Summary</b>
<b>TEG-091</b>	<b>Opel_Report</b>
<b>TEG-092</b>	<b>FTSS_Proposal</b>
<b>TEG-093</b>	<b>JAMA-JARI_Study_for_Inverse_Test_090517</b>
<b>TEG-094</b>	<b>BASt_Tentative_Corridor_Inverse_Test</b>
<b>TEG-095</b>	<b>JAMA_Investigation_Human_MCL_Injury_Criteria</b>
<b>TEG-096</b>	<b>Correlation_Flex-GTR-proto_and_Human_Lower_Limb_Output</b>
<b>TEG-097</b>	<b>JAMA_Proposal_Flex-GTR-proto_Tibia_MCL_Threshold</b>
<b>TEG-098</b>	<b>BASt_Proposal_Flex-GTR-proto_Tibia_Threshold</b>
<b>TEG-099</b>	<b>Evaluation_Test_Schedule_Flex-GTR-proto</b>
<b>TEG-100</b>	<b>DRAFT_Minutes_8th_Flex-TEG_Meeting_090812</b>
<b>TEG-100- Rev.1</b>	<b>Final: 8th Flex-TEG Minutes</b>
<b>TEG-101</b>	<b>DRAFT: 9th Flex-TEG Agenda</b>
<b>TEG-101- Rev.1</b>	<b>Final: 9th Flex-TEG Agenda</b>
<b>TEG-102</b>	<b>Review of Dynamic Calibration Corridor Making Method</b>
<b>TEG-103</b>	<b>DRAFT: Status of Action Items</b>
<b>TEG-103- Rev.1</b>	<b>Final: Status of Action Items</b>
<b>TEG-104</b>	<b>Pushing surface Information for Flex-GTR-prototype for Flex-GTR-prototype</b>
<b>TEG-105</b>	<b>JAMA Round Robin Test Results Flex-GTR-prototype (SN03)</b>
<b>TEG-106</b>	<b>ACEA Comments, 9th TEG meeting</b>

<i>Number of working paper</i>	<i>Title of Flex TEG document</i>
<b>TEG-107</b>	<b>9th Flex-TEG Meeting Discussion Results of day 1</b>
<b>TEG-108</b>	<b>Refinement of (tentative) Certification Corridors for the Dynamic Full Assembly (Inverse) Certification Test Procedure</b>
<b>TEG-109</b>	<b>DRAFT: 9th Flex-TEG Minutes</b>
<b>TEG-109- Rev.1</b>	<b>Final: 9th Flex-TEG Minutes</b>
<b>TEG-110</b>	<b>DRAFT: 10th Flex-TEG Agenda</b>
<b>TEG-110- Rev.1</b>	<b>Final: 10th Flex-TEG Agenda</b>
<b>TEG-111</b>	<b>DRAFT: Status of Action Items</b>
<b>TEG-111- Rev.1</b>	<b>Final: Status of Action Items</b>
<b>TEG-112</b>	<b>Flex-GTR Testing, NHTSA</b>
<b>TEG-113</b>	<b>KATRI Round Robin Tests Using the Flex-GTR-Prototype (SN03)</b>
<b>TEG-114</b>	<b>ACEA Comments, 10th Flex-TEG Meeting</b>
<b>TEG-115</b>	<b>Influence of Test Parameter Variations on The Flex GTR Joint Project of ACEA and BAST</b>
<b>TEG-116</b>	<b>Impact Parameter Tolerances for Inverse Certification Test and Vehicle Testing, BAST</b>
<b>TEG-117</b>	<b>Minor updates and pusher plate discussion for Flex Pli GTR, FTSS</b>
<b>TEG-118</b>	<b>General Status from FLEX Pli GTR Model Consortium, FTSS</b>
<b>TEG-119</b>	<b>Finalization of Impact and Assessment Conditions for Inverse Certification Test, BAST</b>
<b>TEG-120</b>	<b>Requirement Corridor (BAST-Method) for Pendulum Type (Type 3) Dynamic Calibration Test Method, JAMA-JARI</b>
<b>TEG-121</b>	<b>Flex-GTR Flesh Dimensions and Mass Tolerance, JAMA-JARI with FTSS communications</b>
<b>TEG-122</b>	<b>Flex-GTR (Mass, COG, Inertia) Tolerances , JAMA-JARI with FTSS communications</b>
<b>TEG-123</b>	<b>SLICE Updates for FLEX-GTR, DTS</b>

22

## B. Text of the regulation

*Paragraph 4.1.1.*, amend to read:

“4.1.1. Lower legform to bumper

To verify compliance with the performance requirements as specified in paragraph 5.1.1., both the test impactor specified in paragraph 6.3.1.1. and the test procedures specified in paragraph 7.1.1. **for the EEVC WG17 pedestrian lower legform impactor, or both the test impactor specified in paragraph 6.3.1.2. and the test procedures specified in paragraph 7.1.2. for the FlexPLI**, shall be used **respectively.**”

*Paragraph 4.1.2.*, amend to read:

“4.1.2. Upper legform to bumper:

To verify compliance with the performance requirements as specified in paragraph 5.1.2., both the test impactor specified in paragraph 6.3.1.3. and the test procedures specified in paragraph 7.1.3. shall be used.”

*Insert a new paragraph 5.1.1.*, to read:

“5.1.1. **When tested in accordance with paragraph 7.1.1. (EEVC WG17 pedestrian lower legform to bumper) or paragraph 7.1.2. (FlexPLI to bumper) according to the choice of manufacturers, the results shall comply with 5.1.1.1. or 5.1.1.2. respectively.**”

*Paragraph 5.1.1. (former)*, renumber as paragraph 5.1.1.1. and amend to read:

“5.1.1.1. When tested in accordance with paragraph 7.1.1. (~~lower legform to bumper~~), the maximum dynamic knee bending .....

*Insert a new paragraph 5.1.1.2.*, to read:

“5.1.1.2. **When tested in accordance with paragraph 7.1.2., the maximum dynamic medial collateral ligament elongation at the knee shall not exceed 22 mm, and the dynamic bending moments at the tibia shall not exceed 340 Nm. [The maximum dynamic anterior cruciate ligament and posterior cruciate ligament elongation shall be monitored with a reference value of 13 mm or nothing or mandatory with a reference value of 13 mm]. [In addition, the manufacturer may nominate bumper test widths up to a maximum of 264 mm in total where the tibia bending moment of the FlexPLI shall not exceed [...] Nm].**”

*Paragraph 5.1.2.*, amend to read:

“5.1.2. When tested in accordance with paragraph 7.1.3. (upper legform to bumper), the instantaneous sum of the impact forces with respect to time shall not exceed 7.5 kN and the bending moment on the test impactor shall not exceed 510 Nm.”

*Title of paragraph 6.3.1.1.*, amend to read:

“6.3.1.1. **EEVC WG17 pedestrian** ~~Lower legform impactor:~~”

*Title of Figure 12.*, amend to read:

“Figure 12: **EEVC WG17 pedestrian** ~~Lower legform impactor~~ (see paragraph 6.3.1.1.)”

*Insert new paragraphs 6.3.1.2. to 6.3.1.2.7.2.*, to read:

**“6.3.1.2. Flexible pedestrian lower legform impactor (FlexPLI):**

The lower legform impactor shall consist of flesh, flexible long bone segments (representing femur and tibia), and a knee joint as shown in Figure 13.

The overall length of the impactor shall be  $928 \pm 3$  mm, having a required mass of  $13.2 \pm 0.7$  kg including flesh. The length of the femur, knee joint, and tibia shall be  $339 \pm 2$  mm,  $185 \pm 1$  mm, and  $404 \pm 2$  mm respectively. The knee joint centre position shall be  $94 \pm 1$  mm from the top of the knee joint.

Brackets, pulleys, protectors, connection parts etc. attached to the impactor for the purpose of launching and/or protecting may extend beyond the dimensions shown in Figure 13.

**6.3.1.2.1.** The cross-sectional shape perpendicular to the Z axis of the femur and tibia main bodies shall be  $90 \pm 2$  mm in width along the Y axis, and  $84 \pm 1$  mm in width along the X axis as shown in Figure 14 (a). The impact face shall be  $30 \pm 1$  mm in radius,  $30 \pm 1$  mm in width along the Y axis, and  $48 \pm 1$  mm in width along the X axis as shown in Figure 14 (a).

**6.3.1.2.2.** The cross-sectional shape perpendicular to the Z axis of the knee joint shall be  $108 \pm 2$  mm in width along the Y axis, and  $118 \pm 1$  mm in width along the X axis as shown in Figure 14 (b). The impact face shall be  $103 \pm 1$  mm in radius,  $12 \pm 1$  mm in width along the Y axis, and  $86 \pm 1$  mm in width along the X axis as shown in Figure 14 (b).

**6.3.1.2.3.** The masses of the femur and tibia without flesh, including the connection part to the knee joint, shall be  $2.46 \pm 0.12$  kg and  $2.64 \pm 0.13$  kg respectively. The mass of the knee joint without flesh shall be  $4.28 \pm 0.21$  kg. The total mass of the femur, knee joint, and tibia shall be  $9.38 \pm 0.47$  kg.

The centre of gravity of the femur and tibia without flesh, including the connection part to the knee joint, shall be  $159 \pm 8$  mm and  $202 \pm 10$  mm respectively from the top, but not including the connection part to the knee joint, of each part as shown in Figure 13. The centre of gravity of the knee shall be  $92 \pm 5$  mm from the top of the knee joint as shown in Figure 13.

The moment of inertia of the femur and tibia without flesh, including the connection part inserted to the knee joint, about the X axis through the respective centre of gravity shall be  $0.0325 \pm 0.0016$  kgm<sup>2</sup> and  $0.0467 \pm 0.0023$  kgm<sup>2</sup> respectively. The moment of inertia of the knee joint about the X axis through the respective centre of gravity shall be  $0.0180 \pm 0.0009$  kgm<sup>2</sup>.

**6.3.1.2.4.** For each test, the impactor (femur, knee joint, and tibia) shall be covered by flesh composed of synthetic rubber sheets (R1, R2) and neoprene sheets (N1F, N2F, N1T, N2T, N3) as shown in Figure 15. The sheets are required to have a compression characteristic as shown in Figure 16. The compression characteristic shall be checked using the same batch of sheets as those used for the impactor flesh. The size of the sheets shall be within the requirements described in Figure 16.

**6.3.1.2.5.** The test impactor or at least the flesh shall be stored for at least four hours in a controlled storage area with a stabilised temperature

of  $20 \pm 2^\circ\text{C}$  prior to impactor removal for calibration. After removal from the storage, the impactor shall not be subjected to conditions other than those pertaining in the test area.

**6.3.1.2.6. Lower legform instrumentation**

**6.3.1.2.6.1.** Four transducers shall be installed in the tibia to measure bending moments applied to the tibia. The sensing locations of each of the transducers are as follows: tibia-1:  $134 \pm 1$  mm, tibia-2:  $214 \pm 1$  mm, tibia-3:  $294 \pm 1$  mm, and tibia-4:  $374 \pm 1$  mm below the knee joint centre respectively as shown in Figure 17. The measurement axis of each transducer shall be the X axis of the impactor.

**6.3.1.2.6.2.** Three transducers shall be installed in the knee joint to measure elongations of the medial collateral ligament (MCL), anterior cruciate ligament (ACL), and posterior cruciate ligament (PCL). The measurement locations of each transducer are shown in Figure 17. The measurement locations shall be within  $\pm 3$  mm along the X axis from the knee joint centre.

**6.3.1.2.6.3.** The instrumentation response value channel frequency class (CFC), as defined in ISO 6487:2002, shall be 180 for all transducers. The CAC response values, as defined in ISO 6487:2002, shall be 30 mm for the knee ligament elongations and 400 Nm for the tibia bending moments. This does not require that the impactor itself be able to physically elongate or bend until these values.

**6.3.1.2.7. Lower legform certification**

**6.3.1.2.7.1.** The lower legform impactor shall meet the performance requirements specified in paragraph 8.

**6.3.1.2.7.2.** The impactor has to be certified according to the inverse type dynamic certification test described in 8.1.2.3. in advance of to start the homologation test series. The certified impactor shall be certified according to the pendulum type dynamic certification test described in 8.1.2.2 after every 10 car tests\*, as well as inverse type dynamic certification test after every 30 car tests (\*no need to perform pendulum type dynamic certification test after every 30 car tests). The impactor shall be re-certified by these dynamic tests if more than one year has elapsed since the previous dynamic certification tests, if any impactor transducer output has exceeded the specified CAC. If the impactor fails the dynamic certification tests, it shall be re-certified by using the static calibration test described in 8.1.2.1. in order to identify the parts that shall be changed to new ones.”

Insert new Figures 13 to 17., to read:

“

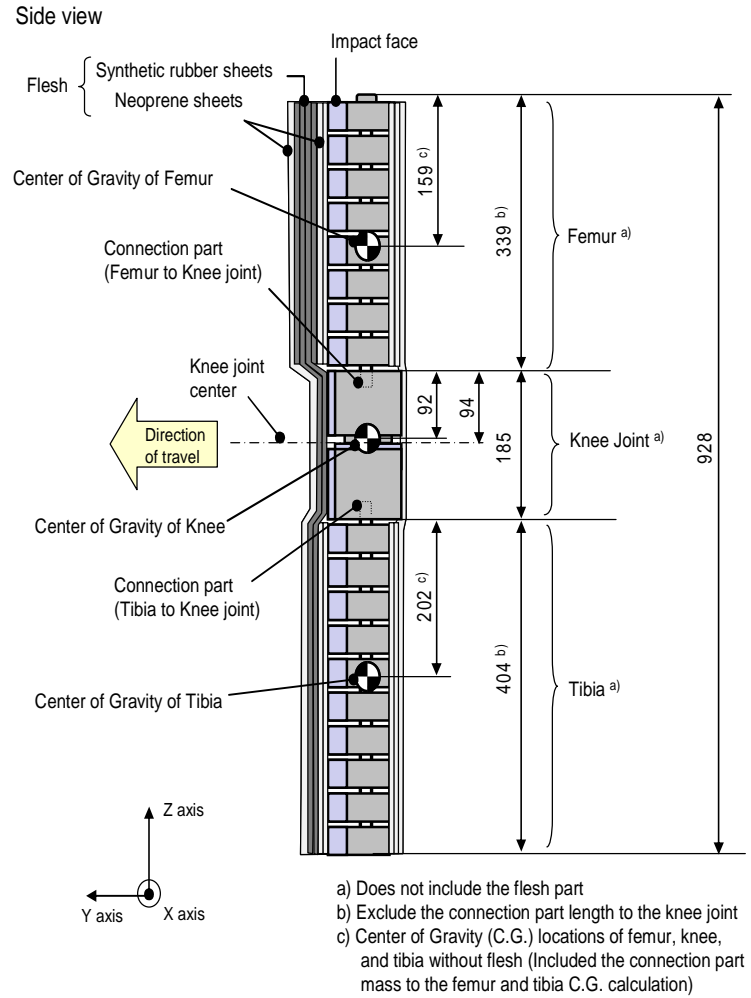

**Figure 13: FlexPLI; Dimensions and C.G. locations of femur, knee joint, and tibia (Side view)**

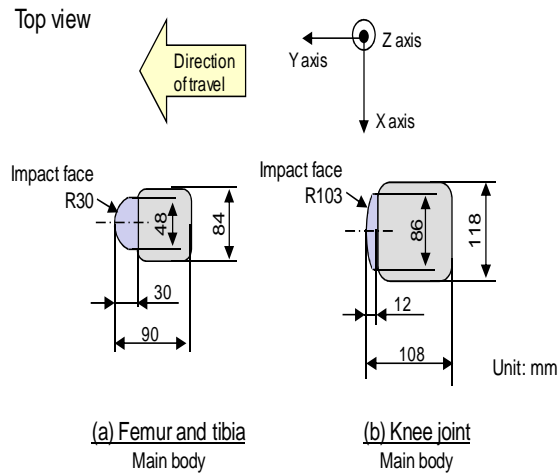

Figure 14: FlexPLI; femur, tibia, and knee dimensions (Top view)

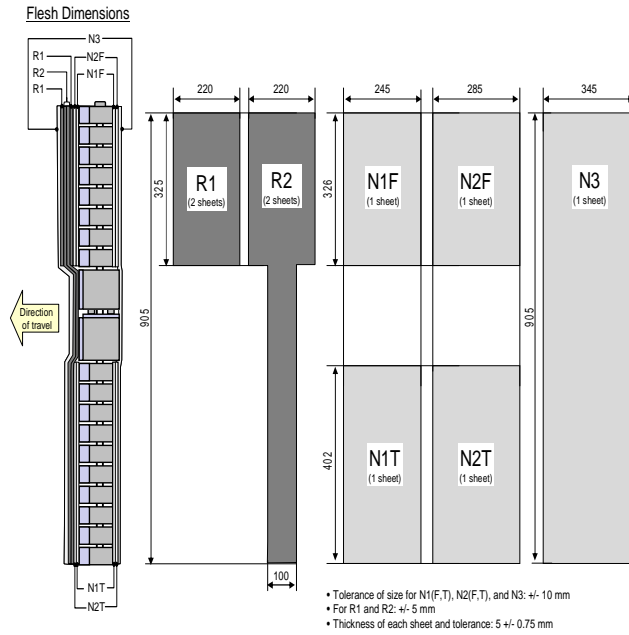
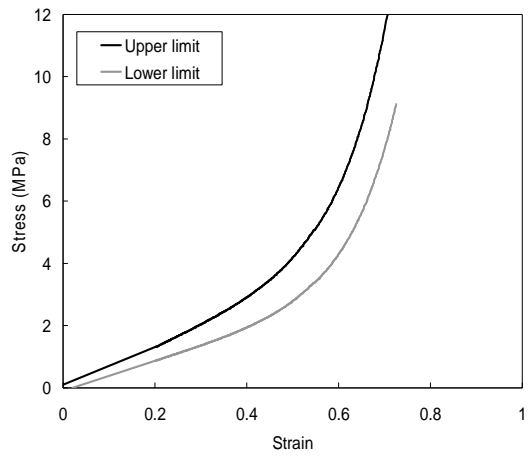
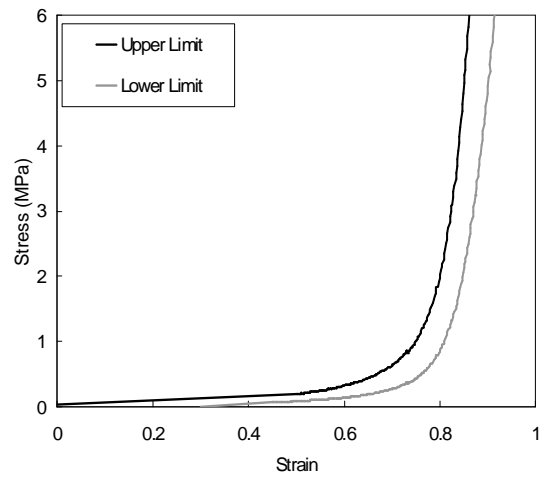

Figure 15: FlexPLI; flesh dimensions



(a) Synthetic rubber sheets



(b) Neoprene sheets

Figure 16: FlexPLI; flesh compression characteristics



Instruments locations

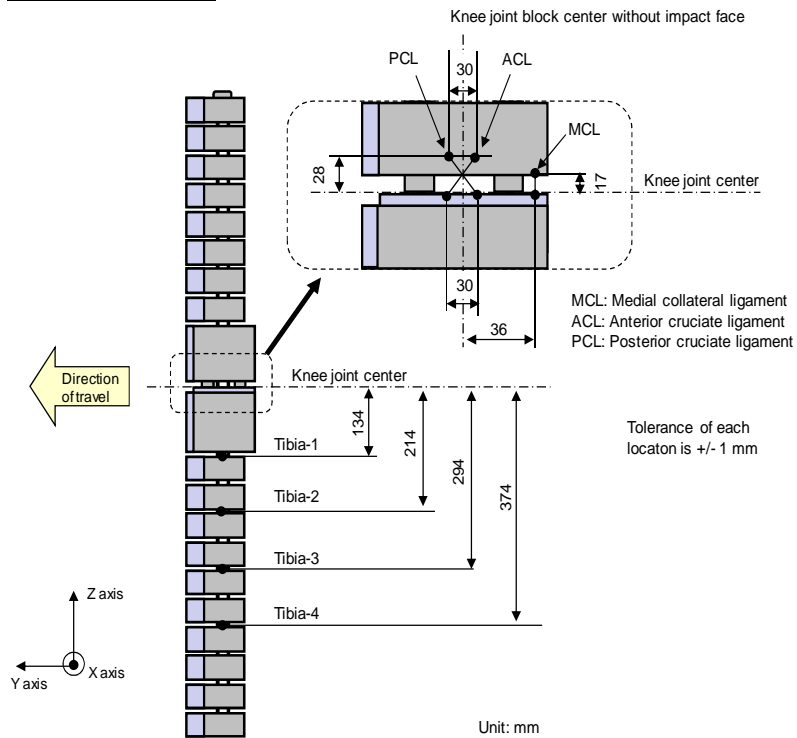

**Figure 17: FlexPLI; instrument locations”**

Paragraph 6.3.1.2. (former), renumber as paragraph 6.3.1.3. and amend to read:

“**6.3.1.3.** ..., foam covered at the impact side, and  $350 \pm 5$  mm long (see Figure ~~4318~~.)”

Paragraphs 6.3.1.2.1. to 6.3.1.2.9. (former), renumber as paragraphs 6.3.1.3.1. to 6.3.1.3.9.

Paragraph 6.3.1.2.9.1. (former), renumber as paragraph 6.3.1.3.9.1. and amend to read:

“**6.3.1.3.9.1.** ...in three positions, as shown in Figure ~~4318~~, each using a separate channel. ....”

Paragraph 6.3.1.2.9.2. (former), renumber as paragraph 6.3.1.3.9.2. and amend to read:

“**6.3.1.3.9.2.** ...at positions 50 mm either side of the centre line (see Figure ~~4318~~.)”

Paragraphs 6.3.1.2.9.3. to 6.3.1.2.10.2. (former), renumber as paragraphs 6.3.1.3.9.3. to 6.3.1.3.10.2.

Title of Figure 13, amend to read:

“Figure 13: Upper legform impactor (see paragraph 6.3.1.3.)”

Paragraph 6.3.2.1., amend to read:

“6.3.2.1. Child headform impactor (see Figure ~~4419~~)

The child.....”

Paragraph 6.3.2.1.1., amend to read:

“6.3.2.1.1. ... axis perpendicular to the mounting face A (see Figure ~~1419~~) and ...”

Figure 14 (former), renumber as Figure 19.

Paragraph 6.3.2.2., amend to read:

“6.3.2.2. Adult headform impactor (see Figure ~~1520~~)

The adult.....”

Figure 15 (former), renumber as Figure 20.

Paragraph 6.3.2.2.1., amend to read:

“6.3.2.2.1. ... axis perpendicular to the mounting face A (see Figure ~~1520~~) and ...”

Paragraph 7.1.1., amend to read:

“7.1.1. **EEVC WG 17 pedestrian** ~~Lower legform impactor~~ to bumper test procedure:....”

Paragraph 7.1.1.2., amend to read:

“7.1.1.2. ... and lateral planes are orthogonal to each other (see Figure ~~1621~~).”

Paragraph 7.1.1.3., amend to read:

“7.1.1.3. ... at the time of first contact with the bumper (see Figure ~~1722~~), ...”

Paragraph 7.1.1.3.2., amend to read:

“7.1.1.3.2. ...its knee joint, with a tolerance of  $\pm 5^\circ$  (see Figure ~~1621~~).”

Figures 16 to 17 (former), renumber as Figures 21 to 22.

Insert new paragraphs 7.1.2. to 7.1.2.4., to read:

“7.1.2. **FlexPLI to bumper test procedure**

**Each test shall be completed within two hours of when the impactor to be used is removed from the controlled storage area.**

7.1.2.1. **The selected target points shall be in the bumper test area.**

7.1.2.2. **The direction of the impact velocity vector shall be in the horizontal plane and parallel to the longitudinal vertical plane of the vehicle. The tolerance for the direction of the velocity vector in the horizontal plane and in the longitudinal plane shall be  $\pm 2^\circ$  at the time of first contact. The axis of the impactor shall be perpendicular to the horizontal plane, with a roll and pitch angle tolerance of  $\pm 2^\circ$  in the lateral and longitudinal plane. The horizontal, longitudinal and lateral planes are orthogonal to each other (see Figure 23).**

7.1.2.3. **The bottom of the impactor shall be at 75 mm above ground reference plane at the time of first contact with the bumper (see Figure 24), with a  $\pm 10$  mm tolerance. When setting the height of the propulsion system, an allowance must be made for the influence of gravity during the period of free flight of the impactor.**

7.1.2.3.1. **The lower legform impactor for the bumper tests shall be in 'free flight' at the moment of impact. The impactor shall be released to free flight at such a distance from the vehicle that the test results are not influenced**

by contact of the impactor with the propulsion system during rebound of the impactor.

The impactor may be propelled by an air, spring or hydraulic gun, or by other means that can be shown to give the same result.

- 7.1.2.3.2. At the time of first contact the impactor shall have the intended orientation about its vertical axis, for the correct operation of its knee joint, with a yaw angle tolerance of  $\pm 5^\circ$  (see Figure 23).
- 7.1.2.3.3. At the time of first contact the centre line of the impactor shall be within a  $\pm 10$  mm tolerance to the selected impact location.
- 7.1.2.3.4. During contact between the impactor and the vehicle, the impactor shall not contact the ground or any object which is not part of the vehicle.
- 7.1.2.4. The impact velocity of the impactor when striking the bumper shall be  $11.1 \pm 0.2$  m/s. The effect of gravity shall be taken into account when the impact velocity is obtained from measurements taken before the time of first contact.”

Insert new Figures 23 and 24., to read:

“

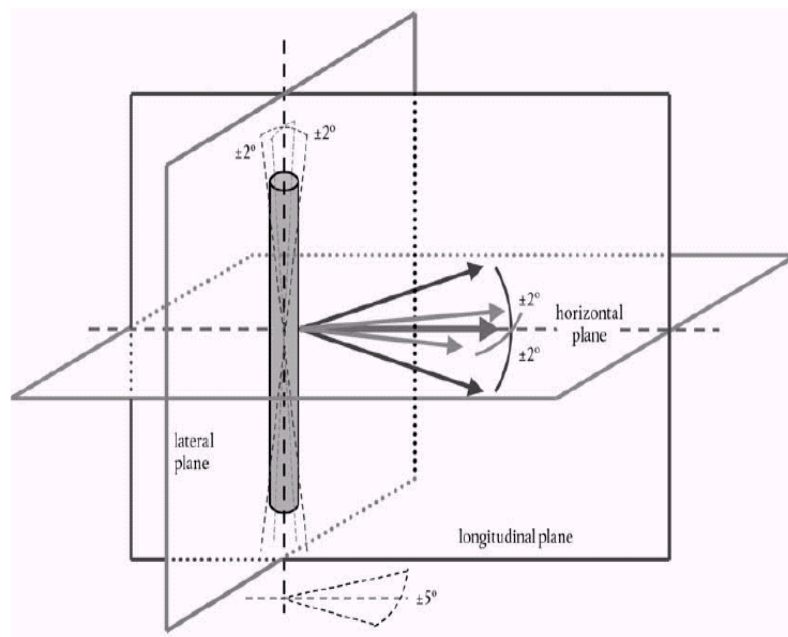
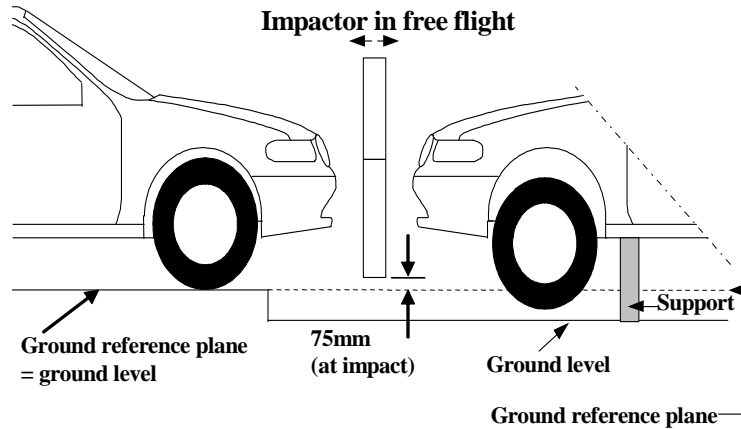

Figure 23: Tolerances of angles for the lower legform impactor at the time of the first impact (see paragraphs 7.1.2.2. and 7.1.2.3.2.)



**Figure 24: FlexPLI to bumper tests for complete vehicle in normal ride attitude (left) and for cut-body mounted on supports (right) (see paragraph 7.1.2.3.)**

Paragraphs 7.1.2. to 7.1.2.3. (former), renumber as paragraphs 7.1.3. to 7.1.3.3.

Paragraph 8., amend to read:

“8. ...The requirements for the lower legform impactor are specified in paragraph 8.1. or 8.2., the upper legform impactor requirements are specified in paragraph 8.28.3. and the adult and child headform impactors requirements are specified in paragraph 8.38.4.”

Paragraph 8.1., amend to read:

“8.1. **EEVC WG 17 pedestrian Lower legform impactor certification**”

Paragraph 8.1.1.2., amend to read:

“8.1.1.2. ... shall be within the limits shown in Figure 4825. Also, the energy ...”

Paragraph 8.1.1.3., amend to read:

“8.1.1.3. ...shall be within the limits shown in Figure 4926.”

Paragraph 8.1.1.4., amend to read:

“8.1.1.4. ... firmly to the femur, as shown in Figure 2027. The rotational axis ...”

Paragraph 8.1.1.5., amend to read:

“8.1.1.5. ... from the centre of the knee joint, as shown in Figure 2428. ...”

Paragraph 8.1.2.4.1., amend to read:

“8.1.2.4.1. ...of 2000 mm minimum length, as shown in Figure 2229. It shall be ...”

Paragraph 8.1.2.4.2., amend to read:

“8.1.2.4.2. ...the certification impactor shall be as specified in Figure 2330. The face of ...”

Paragraph 8.1.2.4.5., amend to read:

“8.1.2.4.5 ...the stationary impactor as shown in Figure 2330. The certification impactor ...”

Insert new paragraphs 8.2. to 8.2.3.4.4., to read:

**“8.2.            FlexPLI certification**

**8.2.1.            Static certification tests**

**8.2.1.1.        The femur and tibia of the lower legform impactor shall meet the requirements respectively specified in paragraph 8.2.1.2. when tested as specified in paragraph 8.2.1.4. The knee joint of the lower legform impactor shall meet the requirements specified in paragraph 8.2.1.3. when tested as specified in paragraph 8.2.1.5. The stabilised temperature of the impactor during the certification tests shall be  $20^{\circ} \pm 2^{\circ}\text{C}$ .**

**The CAC response values, as defined in ISO 6487:2002, shall be 30 mm for the knee ligament elongations and 5 kN for the applied external load. For these tests low-pass filtering at an appropriate frequency is permitted, to remove higher frequency noise without significantly affecting the measurement of the response of the impactor.**

**8.2.1.2.        When the femur and tibia of the impactor are loaded in bending in accordance with paragraph 8.2.1.4., the applied moment and generated deflection at the centre of the femur and tibia ( $M_c$  and  $D_c$ ) shall be within the corridors shown in Figure 31.**

**8.2.1.3.        When the knee joint of the impactor is loaded in bending in accordance with paragraph 8.2.1.5., the MCL, ACL, and PCL elongations and applied bending moment or force at the centre of the knee joint ( $M_c$  or  $F_c$ ) shall be within the corridors shown in Figure 32.**

**8.2.1.4.        The edges of the femur and tibia, not bending parts, shall be mounted to the support rig firmly as shown in Figure 33. The Y axis of the impactor shall be parallel to the loading axis within  $180 \pm 2^{\circ}$  tolerance. In order to avoid friction errors, roller plates shall be set underneath the support rigs. To avoid impactor damage, a neoprene sheet shall be set underneath the loading ram. The neoprene sheet used in this test shall have compression characteristics as shown in Figure 16.**

**The centre of the loading force shall be applied at the centre of the femur and tibia within  $\pm 2^{\circ}$  tolerance along the Z axis. The force shall be increased at a rate between 10 and 100 mm/minute until the bending moment at the centre part ( $M_c$ ) of the femur or tibia reaches [340] Nm.**

**8.2.1.5.        The edges of the knee joint, not bending parts, shall be mounted to the support rig firmly as shown in Figure 35. The Y axis of the impactor shall be parallel to the loading axis within  $180 \pm 2^{\circ}$ . In order to avoid friction errors, roller plates shall be set underneath the support rigs. To avoid impactor damage, a neoprene sheet shall be set underneath the loading ram and the impactor face of the knee joint which is described in the Figure 14 shall be removed. The neoprene sheet used in this test shall have compression characteristics as shown in Figure 16.**

**The centre of the loading force shall be applied at the centre of the knee joint within  $\pm 2^{\circ}$  tolerance along the Z axis. The external load shall be increased at a rate between 10 and 100 mm/minute until the bending moment at the centre part of the knee joint ( $M_c$ ) reaches 300 Nm.**

**8.2.2.            Dynamic certification tests (pendulum type)**

- 8.2.2.1. The lower legform impactor (femur, knee joint, and tibia are connected/assembled firmly) shall meet the requirements specified in paragraph 8.2.2.3. when tested as specified in paragraph 8.2.2.4.
- 8.2.2.2. Certification
  - 8.2.2.2.1. The test facility used for the certification test shall have a stabilised temperature of  $20 \pm 2$  °C during certification.
  - 8.2.2.2.2. The temperature of the certification area shall be measured at the time of certification and recorded in a certification report.
- 8.2.2.3. Requirements
  - 8.2.2.3.1. When the lower legform impactor is used for a test as specified in paragraph 8.2.2.4., the maximum bending moment of the tibia at tibia-1 shall be not more than 272 Nm and not less than 235 Nm, the maximum bending moment at tibia-2 shall be not more than 211 Nm and not less than 185 Nm, the maximum bending moment at tibia-3 shall be not more than 160 Nm and not less than 135 Nm, and the maximum bending moment at tibia-4 shall be not more than 108 Nm and not less than 94 Nm. The maximum elongation of MCL shall be not more than 26 mm and not less than 23 mm, the maximum elongation of ACL shall be not more than 11 mm and not less than 9.0 mm, and the maximum elongation of PCL shall be not more than 5.4 mm and not less than 4.0 mm.
 

For all these values, the readings used shall be from the initial impact timing to 250 ms after the impact timing.
  - 8.2.2.3.2. The instrumentation response value CFC, as defined in ISO 6487:2002, shall be 180 for all transducers. The CAC response values, as defined in ISO 6487:2002, shall be 30 mm for the knee ligament elongations and 400 Nm for the tibia bending moments. This does not require that the impactor itself be able to physically elongate and bend to these values.
- 8.2.2.4. Test procedure
  - 8.2.2.4.1. The impactor, including flesh, shall be suspended from the dynamic certification test rig  $15 \pm 1^\circ$  upward from the horizontal as shown in Figure 36. The impactor shall be released from the suspended position, whereupon the impactor falls freely against the pin joint of the test rig as shown in Figure 36.
  - 8.2.2.4.2. The knee joint centre of the impactor shall be  $30 \pm 1$  mm below the bottom line of the stopper bar, and the tibia impact face shall be located  $13 \pm 1$  mm from the front upper edge of the stopper bar when the stopper block is removed from the stopper bar and then hung from the impactor without any contact (see Figure 36).
- 8.2.3. Dynamic certification tests (inverse type)
  - 8.2.3.1. The lower legform impactor with flesh (femur, knee joint, and tibia are connected/assembled firmly) shall meet the requirements specified in paragraph 8.2.3.3. when tested as specified in paragraph 8.2.3.4.
  - 8.2.3.2. Certification
    - 8.2.3.2.1. The test facility used for the certification test shall have a stabilised temperature of  $20 \pm 2$  °C during certification.

- 8.2.3.2.3. The temperature of the certification area shall be measured at the time of certification and recorded in a certification report.
- 8.2.3.3. Requirements
- 8.2.3.3.1. When the lower legform impactor is used for the test specified in paragraph 8.2.3.4., the maximum bending moment of the tibia at tibia-1 shall be not more than 277 Nm and not less than 237 Nm, the maximum bending moment at tibia-2 shall be not more than 269 Nm and not less than 223 Nm, the maximum bending moment at tibia-3 shall be not more than 204 Nm and not less than 176 Nm, and the maximum bending moment at tibia-4 shall be not more than 120 Nm and not less than 98 Nm. The maximum elongation of the MCL shall be not more than 23 mm and not less than 18 mm, that of the ACL shall be not more than 10.5 mm and not less than 8.5 mm, and that of the PCL shall be not more than 6 mm and not less than 4.5 mm.
- For all these values, the readings used shall be from the initial impact timing to 50 ms after the impact timing.
- 8.2.3.3.2. The instrumentation response value CFC, as defined in ISO 6487:2002, shall be 180 for all transducers. The CAC response values, as defined in ISO 6487:2002, shall be 30 mm for the knee ligament elongations and 400 Nm for the tibia bending moments. This does not require that the impactor itself be able to physically elongate and bend to these values.
- 8.2.3.4. Test procedure
- 8.2.3.4.1. The fully assembled FlexPLI (with flesh and skin) shall be stationary suspended vertically from a test rig as shown in Figure 37. It is then impacted by the upper edge of a linearly guided Al honeycomb impactor, covered by a thin (less than 1 mm thickness) paper cloth, at an impact speed of  $11,1 \pm 0,2$  m/s. The legform is to be released from the test rig within 5 ms after the time of first contact to ensure a free flight condition.
- 8.2.3.4.2. The honeycomb of 5052 alloy, which is attached in front of the moving ram, shall have a crash strength of  $75 \pm 10$  per cent psi and dimensions of  $l=200 \pm 2$  mm,  $w = 160 \pm 2$  mm and  $d = 60 \pm 5$  mm. To ensure a consistent and good level of repeatability, the honeycomb should either have a 3/16 inches cell size in combination with a density of 3.1 pcf or a 1/4 inches cell size in combination with a density of 2.3 pcf or a 3/16 inches cell size in combination with a density of 2.0 pcf.
- 8.2.3.4.3. The upper edge of the honeycomb face is to be in line with the rigid plate of the linearly guided impactor. At time of first contact, the upper edge of the honeycomb is to be in line with the knee joint centre line within a vertical tolerance of  $0 \pm 2$  mm. The honeycomb shall not be excessively handled or deformed before the impact test.
- 8.2.3.4.4. The FlexPLI pitch angle and therefore the pitch angle of the velocity vector of the honeycomb impactor (rotation around y-axis) at the time of first contact shall be within a tolerance of  $0 \pm 2^\circ$  in relation to the lateral vertical plane. The FlexPLI roll angle and therefore the roll angle of the honeycomb impactor (rotation around x-axis) at the time of first contact shall be within a tolerance of  $0 \pm 2^\circ$  in relation to the longitudinal vertical plane. The FlexPLI yaw angle and therefore the yaw angle of the velocity vector of the honeycomb impactor (rotation around z-axis) at the time of

**first contact shall be within a tolerance of  $0\pm 2^\circ$ , to ensure a correct operation of the knee joint.”**

Paragraph 8.2. (former), renumber as paragraph 8.3.

Paragraph 8.2.1. (former), renumber as 8.3.1. and amend to read:

“**8.3.1.** ... specified in paragraph 8.3.3. when tested as specified in paragraph 8.3.4.”

Paragraphs 8.2.2. to 8.2.4.5. (former), renumber as paragraphs 8.3.2. to 8.3.4.5.

Paragraph 8.2.4.6. (former), renumber as paragraph 8.3.4.6. and amend to read:

“**8.3.4.6.** ... at a velocity of  $7.1 \pm 0.1$  m/s into the stationary pendulum as shown in Figure 2438.”

Paragraphs 8.2.4.7. to 8.3.1. (former), renumber as paragraphs 8.3.4.7. to 8.4.1.

Paragraph 8.3.1.1. (former), renumber as paragraph 8.4.1.1. and amend to read:

“**8.4.1.1.** ... specified in paragraph 8.4.2. when tested as specified in paragraph 8.4.3.”

Paragraphs 8.3.2. to 8.3.3. (former), renumber as paragraphs 8.4.2. to 8.4.3.

Paragraph 8.3.3.1. (former), renumber as paragraph 8.4.3.1. and amend to read:

“**8.4.3.1.** ...impactor shall be suspended from a drop rig as shown in Figure 2539.”

Paragraph 8.3.3.2. (former), renumber as paragraph 8.4.3.2.

Paragraph 8.3.3.3. (former), renumber as paragraph 8.4.3.3. and amend to read:

“**8.4.3.3.** ... impactor with respect to the vertical as shown in Figure 2537. The suspension of ...”

Paragraph 8.3.3.4. (former), renumber as paragraph 8.4.3.4.

Figures 18 to 23 (former), renumber as Figures 25 to 30.

Insert new Figures 31 to 37., to read:

“

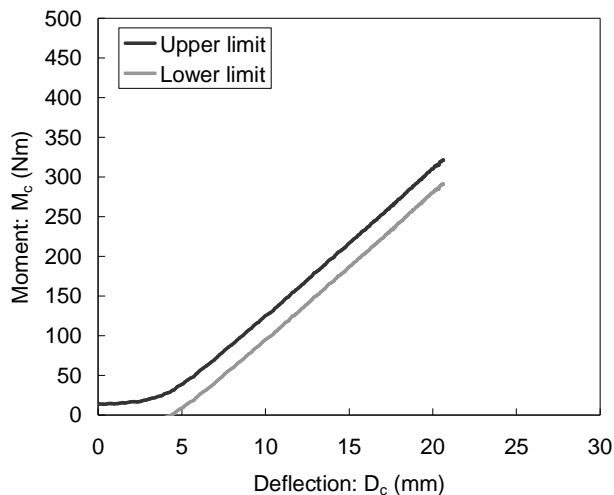

(a) Femur bending corridor



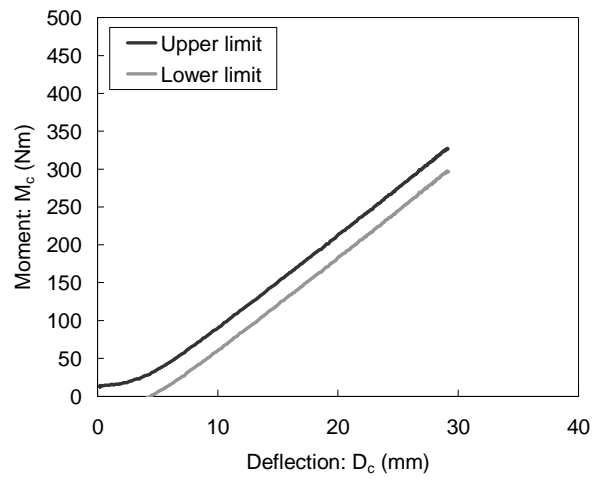

(b) Tibia bending corridor

Figure 31: Requirement corridor of femur and tibia in static certification test (see paragraph 8.2.1.2.)

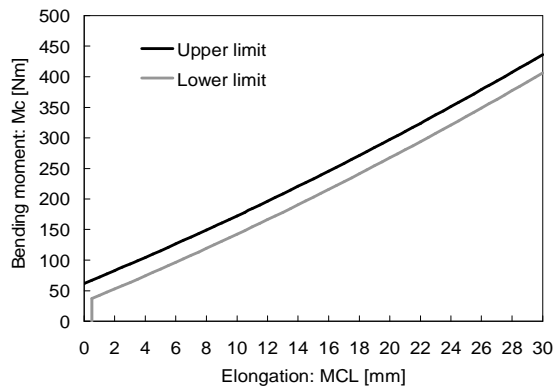

(a) for MCL

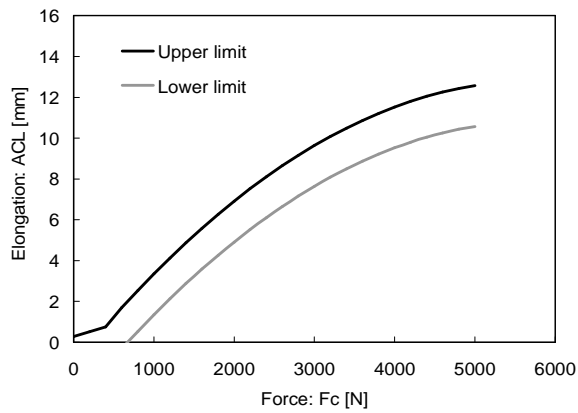

(b) for ACL

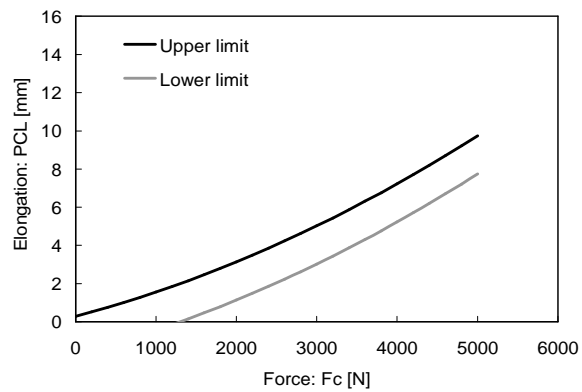

(c) for PCL

**Figure 32: Requirement corridors for knee joint in static certification test (see paragraph 8.2.1.3.)**

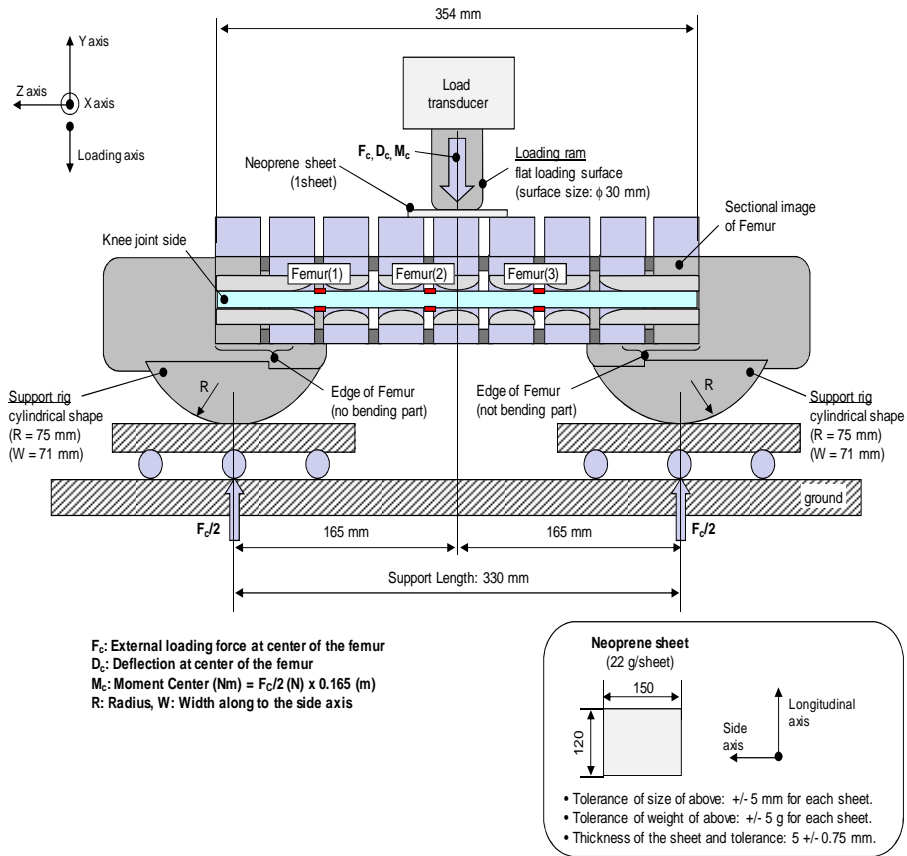

Figure 33: Test set-up for femur in static certification tests (see paragraph 8.2.1.4.)

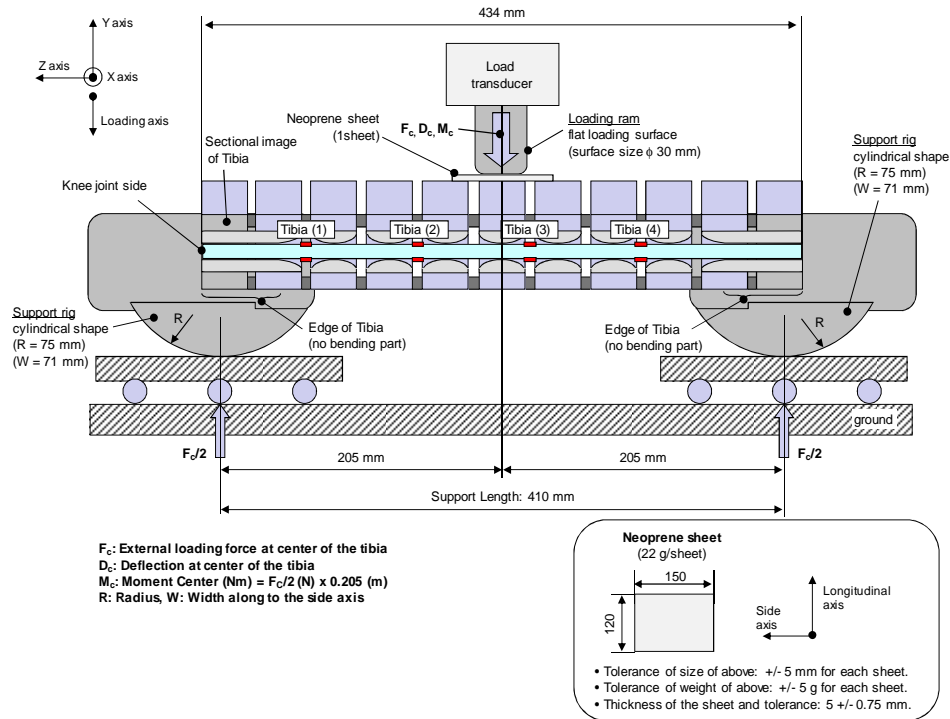

Figure 34: Test set-up for tibia in static certification test (see paragraph 8.2.1.4.)

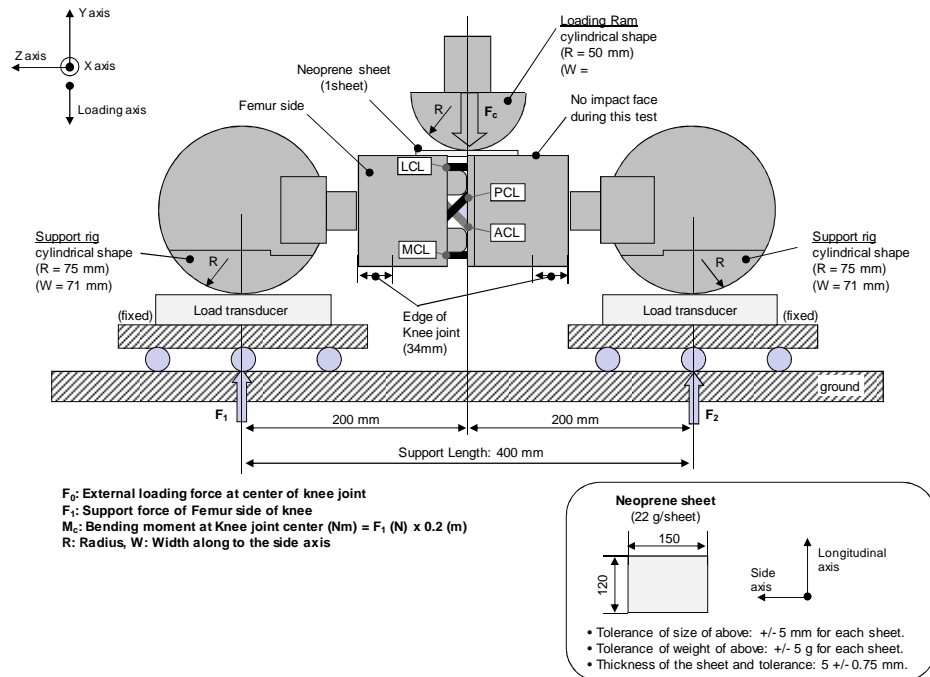

Figure 35: Test set-up for knee joint in static certification test (see paragraph 8.2.1.5.)

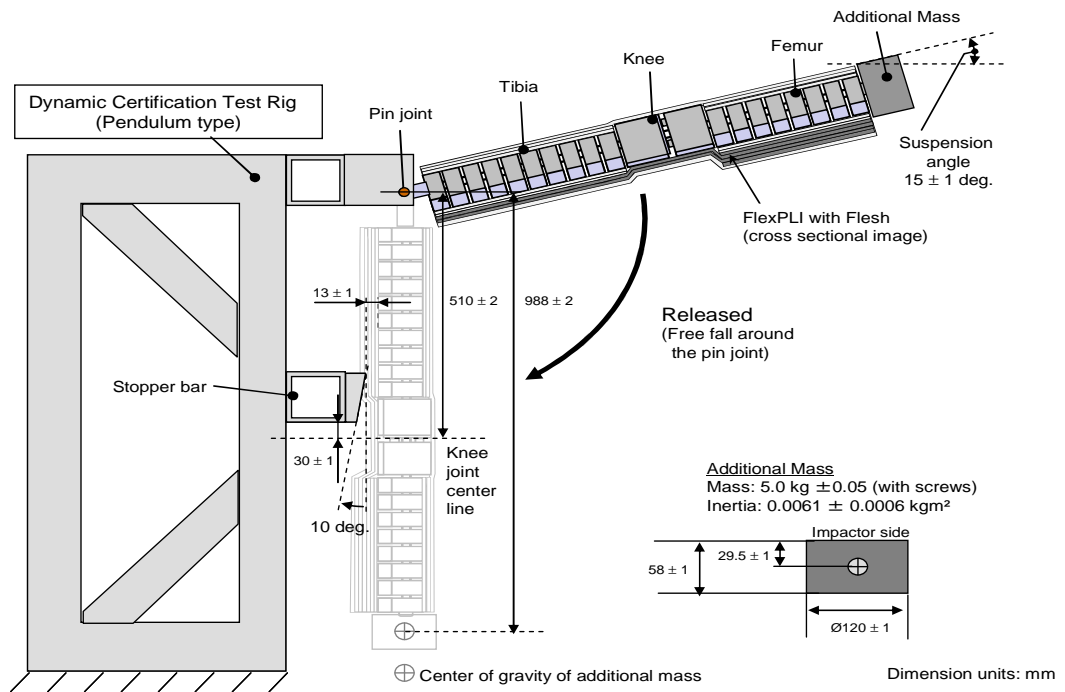

Figure 36: Test set-up for dynamic lower legform impactor certification test, Pendulum type (see paragraph 8.2.2.4.).

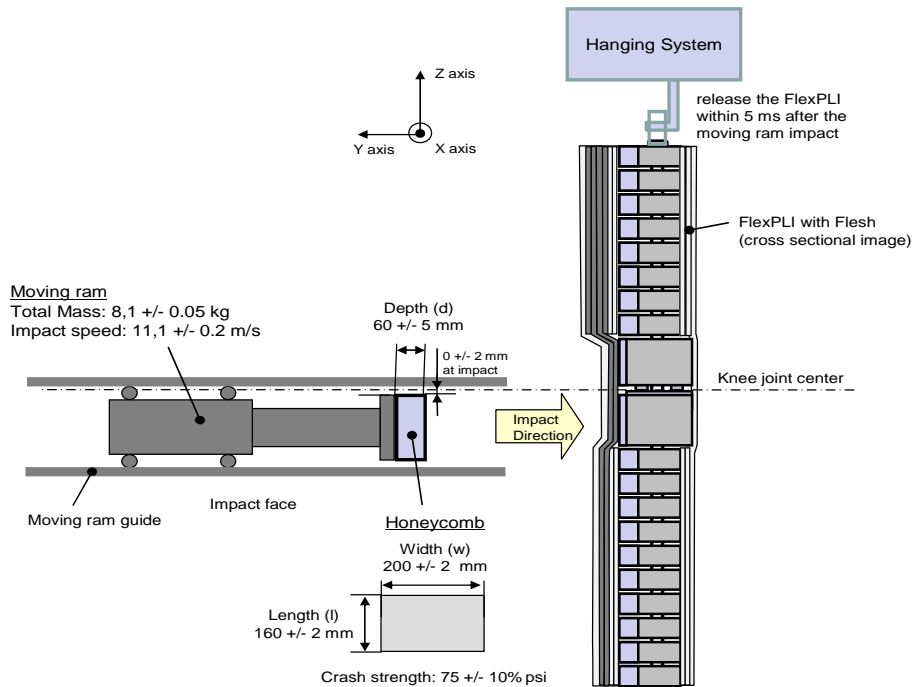

Figure 37: Test set-up for dynamic lower legform impactor certification test, Inverse type (see paragraph 8.2.3.4.).”

*Figures 24 and 25 (former)*, renumber as Figures 38 and 39.

## **II. Justification**

Based on the results of the TEG activities up to now, the expert from Japan proposes the above-mentioned draft amendments to the gtr on pedestrian protection (gtr No. 9) following the responsibility of the TEG chairmanship.

### **A. Statement of technical rationale and justification**

*Paragraph 64*: new text to introduce the TEG activities so far.

*Paragraphs 102, 110, 111, 112, 113, 115*: new text regarding the Flexible Pedestrian Legform Impactor (FlexPLI).

*Paragraph 106*: new text to introduce the TEG activities so far.

*Paragraph 114*: clarification on the EEVC WG17 pedestrian lower legform impactor

*Title of Section 10*: new text on the FlexPLI.

*New paragraph 133.*: new text to introduce the FlexPLI to each Contracting Party smoothly.

*Section 10 (former)*: renumbering (editorial).

### **B. Text of the regulation**

*Paragraph 4.1.1*: clarification on the EEVC WG17 pedestrian lower legform impactor as well as to the FlexPLI.

*Paragraph 4.1.2*: renumbering (editorial).

*Paragraph 5.1.1.*: guidance for the alternative use of the EEVC WG17 pedestrian lower legform and FlexPLI during an alternative period.

*Paragraph 5.1.1.2.*: new text on the FlexPLI.

*Title of Paragraph 6.3.1.1.*: clarification (editorial).

*Title of Figure 12*: clarification (editorial).

*New paragraphs 6.3.1.2. to 6.3.1.2.7.2.*: new paragraphs regarding the FlexPLI.

*New Figures 13 to 17*: new figures regarding the Flex-PLI.

*Paragraph 6.3.1.2. (former)*: renumbering (editorial).

*Paragraph 6.3.1.2.9.1. (former)*: renumbering (editorial).

*Paragraph B. 6.3.1.2.9.2. (former)*: renumbering (editorial).

---

*Title of Figure 13:* renumbering (editorial).

*Title of Paragraph B. 6.3.2.1.:* renumbering (editorial).

*Paragraph B. 6.3.2.1.1.:* renumbering (editorial).

*Figure 14 (former):* renumbering (editorial).

*Title of paragraph 6.3.2.2.:* renumbering (editorial).

*Figure 15 (former):* renumbering (editorial).

*Paragraph 6.3.2.2.1.:* renumbering (editorial).

*Title of paragraph 7.1.1.:* clarification (editorial).

*Paragraph 7.1.1.2.:* renumbering (editorial).

*Paragraph 7.1.1.3.:* renumbering (editorial).

*Paragraph 7.1.1.3.2.:* renumbering (editorial).

*Figure 16 to 17 (former):* renumbering (editorial).

*New paragraphs 7.1.2. to 7.1.2.4.:* new paragraphs regarding the Flex-PLI.

*Figures 23 to 24:* new figures regarding the Flex-PLI.

*Paragraphs 7.1.2. to 7.1.2.3. (former):* renumbering (editorial).

*Paragraph 8.:* renumbering (editorial) and alternative use of the EEVC WG17 pedestrian legform impactor and FlexPLI during an alternative period.

*Title of Paragraph B. 8.1.:* clarification (editorial).

*Paragraph B. 8.1.1.2.:* renumbering (editorial).

*Paragraph B. 8.1.1.3.:* renumbering (editorial).

*Paragraph B. 8.1.1.4.:* renumbering (editorial).

*Paragraph B. 8.1.1.5.:* renumbering (editorial).

*Paragraph B. 8.1.2.4.1.:* renumbering (editorial).

*Paragraph B. 8.1.2.4.2.:* renumbering (editorial).

*Paragraph B. 8.1.2.4.5.:* renumbering (editorial).

*New paragraphs 8.2. to 8.2.3.4.4.:* new paragraphs regarding the FlexPLI.

*Paragraph 8.2. to 8.2.4.7. (former):* renumbering (editorial).

*Paragraph 8.2.1 (former): renumbering (editorial).*

*Paragraph 8.2.4.6. (former): renumbering (editorial).*

*Paragraph 8.3. to 8.3.3.4. (former): renumbering (editorial).*

*Paragraph 8.3.1.1. (former): renumbering (editorial).*

*Paragraph 8.3.3.1. (former): renumbering (editorial).*

*Paragraph 8.3.3.3. (former): renumbering (editorial).*

*Figure 18 to 23 (former): new figures regarding the FlexPLI.*

---