

**Economic and Social Council**Distr.: General
5 March 2010Original: English
English and French only

Economic Commission for Europe

Inland Transport Committee

World Forum for Harmonization of Vehicle Regulations

Working Party on Passive Safety

Forty-seventh session

Geneva, 17–21 May 2010

Item 17 of the provisional agenda

Regulation No. 94 (Frontal collision)**Proposal for 02 series of amendments to Regulation No. 94****Submitted by the expert from France***

The text reproduced below was prepared by the expert from France in order to extend the scope of the present Regulation to all kinds of power train systems above a certain working voltage level. The modifications to the existing text of the Regulation No. 94 are based on discussions held during the meeting of the group of interested experts on Electric Vehicles Post Crash provisions (EVPC), in Paris from 13 to 14 January 2010. It supersedes Informal document No. GRSP-46-04, distributed during the forty-sixth session of the Working Party on Passive Safety (GRSP). The modifications to the existing text of Regulation No. 94 are marked in bold or strikethrough characters.

* In accordance with the programme of work of the Inland Transport Committee for 2006–2010 (ECE/TRANS/166/Add.1, programme activity 02.4), the World Forum will develop, harmonize and update Regulations in order to enhance the performance of vehicles. The present document is submitted in conformity with that mandate.

I. Proposal

Contents,

Insert a new Annex 11 and Appendix 1, to read:

“... ”

Annex 11 - Protection of the occupants of vehicles operating on electric power from high voltage and electrolyte spillage.”

Appendix 1 - Protection against direct contacts of parts under voltage”

Insert new paragraphs 2.6.7., to read:

“2.6.7. [The place of the rechargeable energy storage system (RESS)]”

Modify paragraph 2.7, to read:

“2.7. “Passenger compartment with regard to occupant protection” means the space for occupant accommodation, bounded by the roof, floor, side walls, doors, outside glazing and front bulkhead and the plane of the rear compartment bulkhead or the plane of the rear-seat back support. For the sake of protection of occupants from high voltage and electrolyte spillage according to Annex 11 a different definition (see paragraph 2.32.) is applied.”

Insert new paragraphs 2.15. to 2.33., to read:

- “2.15. “Electric power train” means the electrical circuit which includes the traction motor(s), and may include the RESS, the electric energy conversion system, the electronic converters, the associated wiring harness and connectors, and the coupling system for charging the RESS,**
- 2.16. “Rechargeable energy storage system (RESS)” means rechargeable energy storage system that provides the electric energy for propulsion,**
- 2.17. “Electric energy conversion system” means a system (e.g. fuel cell) that generates and provides electric energy for electric propulsion,**
- 2.18. “Electronic converter” means a device capable of controlling and/or converting electric power for electric propulsion,**
- 2.19. “Coupling system for charging the rechargeable energy storage system (RESS)” means the electrical circuit used for charging the RESS from an external electric power supply including the vehicle inlet,**
- 2.20. “Direct contact” means the contact of persons with live parts,**
- 2.21. “Live parts” means conductive part(s) intended to be electrically energized in normal use,**
- 2.22. “Indirect contact” means the contact of persons with exposed conductive parts,**
- 2.23. “Protection degree” means the Protection provided by a barrier/enclosure related to the contact with live parts by a test probe, such as a test finger (IPXXB) as defined in Appendix 1 of Annex 9.**

- 2.24. “**Exposed conductive part**” means the conductive part which can be touched under the provisions of the protection degree IPXXB, and which becomes electrically energized under isolation failure conditions,
- 2.25. “**Electrical circuit**” means an assembly of connected live parts which is designed to be electrically energized in normal operation,
- 2.26. “**Working voltage**” means the highest value of an electrical circuit voltage root-mean-square (rms), specified by the manufacturer, which may occur between any conductive parts in open circuit conditions or under normal operating conditions. If the electrical circuit is divided by galvanic isolation, the working voltage is defined for each divided circuit, respectively.
- 2.27. “**Electrical chassis**” means a set made of conductive parts electrically linked together, whose potential is taken as reference,
- 2.28. [**Protection Barrier / Protection Shielding / Shielding / Barrier-el/ High Voltage Protection**]” means the part providing protection against direct contact to the live parts from any direction of access,
- 2.29. “**Enclosure**” means the part enclosing the internal units and providing protection against direct contact from any direction of access,
- 2.30. “**High Voltage**” means the classification of an electric component or circuit, if its working voltage is $> 60 \text{ V}$ and $\leq 1500 \text{ V DC}$ or $> 30 \text{ V}$ and $\leq 1000 \text{ V AC}$ root – mean - square (rms),
- 2.31. “**High Voltage Bus**” means the electrical circuit, including the coupling system for charging the RESS that operates on high voltage,
- 2.32. “**Passenger compartment for electric safety assessment**” means the space for occupant accommodation, bounded by the roof, floor, side walls, doors, window glass, front bulkhead and rear bulkhead, or rear gate, as well as by the barriers and enclosures provided for protecting the power train from direct contact with high voltage live parts,
- 2.33. “**Solid insulator**” means insulating coating of wiring harnesses provided in order to cover and protect the live parts against direct contact from any direction of access; covers for insulating the live parts of connectors; and varnish or paint for the purpose of insulation.”

Insert a new paragraph 3.2.6., to read:

- “3.2.6. **General description of the RESS type and [location] and the electric power train (e.g. hybrid, electric)”**

Paragraph 5.2., amend to read:

- “5.2. **Specifications**

The test...at the same time.

[Vehicles equipped with electric power train shall meet the requirements of paragraph 5.2.8. in addition. This could be demonstrated in a separate crash test at the request of the manufacturer, given that the electric components do not influence the occupant protection performance of the vehicle type as defined in paragraphs 5.2.1. to 5.2.5. of this Regulation.]”

Insert new paragraphs 5.2.8. to 5.2.8.3., to read:

- “5.2.8. The electric power train operating on high voltage as well as the high voltage components and systems which are galvanically connected to the high voltage bus of the electric power train shall meet the following requirements:**
- 5.2.8.1. Protection against electrical shock**
- After the impact at least one of the following criteria specified in paragraphs 5.2.8.1.1. to 5.2.8.1.4.2. shall be met. If the vehicle has an automatic disconnect function, at least one of the criteria shall apply to each divided portion individually after the disconnect function is activated.
- 5.2.8.1.1. Absence of high voltage**
- The voltage of the high voltage buses shall be equal or less than 30 VAC or 60 VDC.
- 5.2.8.1.2. Low electrical Energy**
- Energy on the high voltage buses shall be less than 0.2 Joules.
- 5.2.8.1.3. Physical protection**
- For protection of live parts, the protection degree IPXXB shall be provided.
- In addition the resistance between all exposed conductive parts and the electrical chassis shall be lower than 0.1 ohm when there is current flow of at least 0.2 amperes.
- This requirement is satisfied if the galvanic connection has been established by welding.
- 5.2.8.1.4. Isolation resistance**
- 5.2.8.1.4.1. Electric power train consisting of separate DC- or AC-buses**
- If AC high voltage buses and DC high voltage buses are galvanically isolated from each other, isolation resistance between the high voltage bus and the electrical chassis shall have a minimum value of 100 Ω /volt of the working voltage for DC buses, and a minimum value of 500 Ω /volt of the working voltage for AC buses.
- 5.2.8.1.4.2. Electric power train consisting of combined DC- and AC-buses**
- If AC high voltage buses and DC high voltage buses are galvanically connected isolation resistance between the high voltage bus and the electrical chassis shall have a minimum value of 500 Ω /volt of the working voltage.
- However, if the protection degree IPXXB is satisfied for all AC high voltage buses or the AC voltage is equal or less than 30 V after crash, isolation resistance between the high voltage bus and the electrical chassis shall have a minimum value of 100 Ω /volt of the working voltage.
- 5.2.8.2. Electrolyte spillage**
- In the period from the impact until 30 minutes after, no electrolyte from the [RESS] shall spill into the passenger compartment, and no more than [7 per cent / 5.0 liters] of electrolyte shall spill from the [RESS] outside

the passenger compartment. If the electrolyte spillage mixes with other fluids leaking from the vehicle and the liquids cannot be clearly distinguished the total leakage shall be considered electrolyte spillage.

5.2.8.3. [RESS] retention

[RESS] located inside the passenger compartment shall remain in the location in which they are installed and [RESS] components shall remain inside [RESS] boundaries.

No part of any [RESS] that is located outside the passenger compartment shall enter the passenger compartment during the test procedures.”

Annex 1,

Communication,

Insert a new paragraph 5.3., to read:

“**5.3. Location of the electric power source.....”**

Annex 3,

Paragraph 1.4.1., amend to read:

“1.4.1. General specification

The test vehicle...under paragraph 6.

At the request of the manufacturer it shall be allowed to perform the test with the engine or electric energy conversion system running and to allow for the fuel system to be modified in such a way that an appropriate amount of fuel can be used.”

Paragraph 1.4.2.2., amend to read:

“1.4.2.2. The fuel tank shall be filled with water to mass equal to 90 per cent of the mass of a full as specified by the manufacturer with a tolerance of ± 1 per cent;

Alternative gas (i.e. helium gas) or alternative liquid (i.e. liquid nitrogen (LN₂)) can be used instead of hydrogen gas or liquid hydrogen.

However the requirement of paragraph 5.2.8.1.3. shall be satisfied for the hydrogen conversion system disconnected by its automatic disconnect when this alternative is used.”

Insert new paragraphs 1.4.4. to 1.4.4.2., to read:

“**1.4.4. Electrical power train adjustment**

1.4.4.1. The RESS shall be at any state of charge which allows the normal operation of the power train recommended by the manufacturer.

1.4.4.2. [The high voltage system shall be energized.]”

Insert a new Annex 11 and Appendix 1, to read:

“Annex 11

Protection of the occupants of vehicles operating on electric power [against / from] high voltage and electrolyte spillage

This section describes test procedures to demonstrate compliance to the electrical safety requirements of paragraph 5.2.8. For example, megohmmeter or oscilloscope measurements are an appropriate alternative to the procedure described below for measuring isolation resistance.

The following procedures should be performed for each of the specified crash tests.

1. Test setup and equipment

If a high voltage disconnect function is used, measurements are taken from both sides of the device performing the disconnect function.

However, if the high voltage disconnect is integral to the RESS or the energy conversion system and the high-voltage bus of the RESS or the energy conversion system is protected according to class IPXXB after crash test, measurements may be taken only downstream of the device performing the disconnect function.

The voltmeter used in this test shall measure DC values and have an internal resistance of at least 10 MΩ.

Before the vehicle crash test, measure and record the high voltage bus voltage (Vb) (see figure 1) and confirm that it is within the operating voltage of the vehicle as defined by the manufacturer.

2. The following instructions may be used if voltage is measured.

After the crash test, determine the high voltage bus voltages (Vb, V1, V2) (see figure 1). If the RESS has exposed conductive parts, measure the voltage V3 between any exposed conductive parts of it and the electrical chassis.

[The measurement shall be made at 5 seconds after the impact].

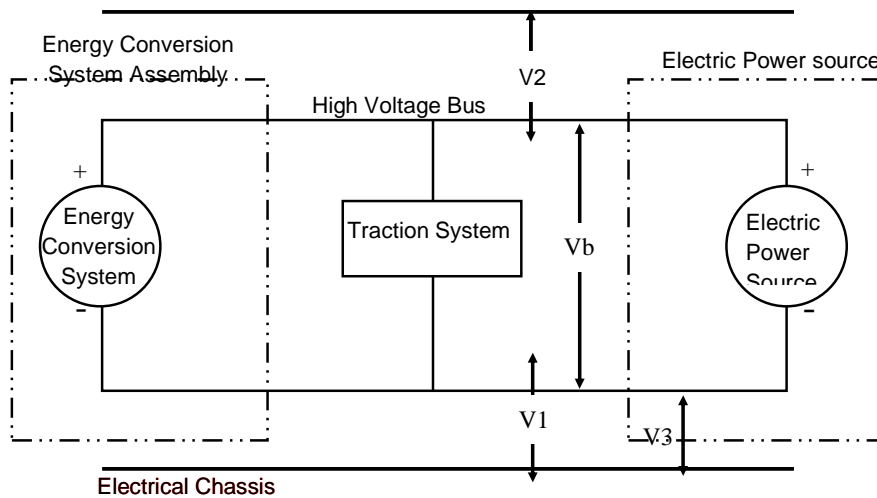

Figure 1: Measurement of Vb, V1, V2, V3

3. Assessment procedure for low electrical Energy

Prior to the impact a switch S1 and a known discharge resistor Re is installed according to figure 2. [At 5 seconds] after the impact the switch S1 is closed while the voltage Vb and the current Ie is measured and recorded. The product of the voltage Vb and the current Ie is integrated over the period of time starting from the moment when the switch S1 is closed (tc) until the voltage Vb falls below the high voltage threshold of 30 V AC or 60 V DC (th), resulting in the total energy (TE) in joules.

$$TE = \int_{t_c}^{t_h} V_b \times I_e dt$$

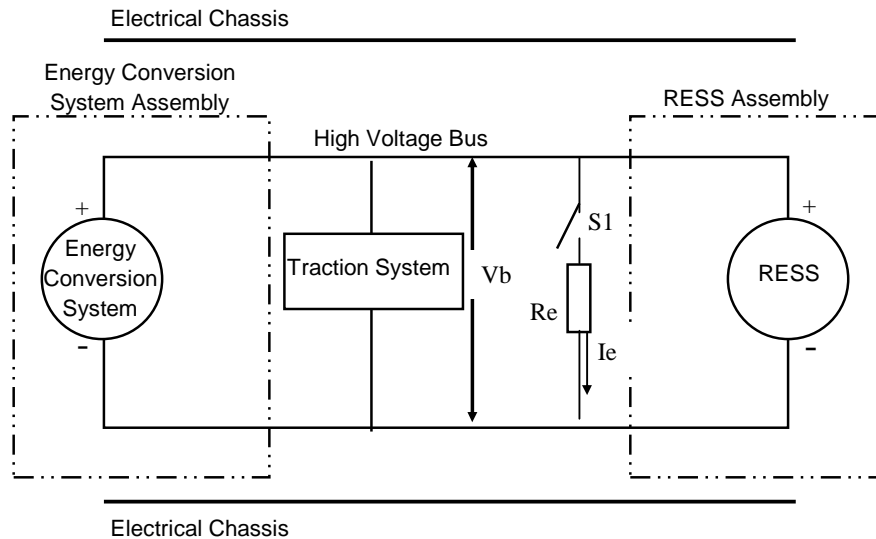

Figure 2: Measurement of high voltage bus energy

4. Physical Protection

The manufacturer shall define the physical barriers, enclosures and solid insulators that protect the human from the direct contact with the high voltage bus in use (hereinafter referred to as the '[original] physical protection').

After crash test any surrounding parts of the high voltage components that can be opened, disassembled or removed without the use of tools shall be opened, disassembled or removed. Only surrounding parts that cannot be opened, disassembled or removed without the use of tools are considered as a part of the [original] physical protection.

The access probe described in Appendix 1 figure 1 is pushed against any openings of the [original] physical protection with the test force of $10\text{ N} \pm 10\%$ per cent. If it partly or fully penetrates into the original physical protection, it is placed in every possible position.

Starting from the straight position, both joints of the test finger shall be successively bent through an angle of up to 90 degree with respect to the axis of the adjoining section of the finger and shall be placed in every possible position.

4.1. Acceptance conditions

The access probe described in Appendix 1, figure 1 shall not touch live parts.

A mirror or a fiberscope may be used in order to inspect whether the access probe touches the high voltage buses, if necessary.

5. Isolation resistance

The following instructions may be used if isolation resistance is measured.

[Before the vehicle crash test, measure and record the high voltage bus voltage (Vb) (see figure 1). Vb must be equal to or greater than the nominal operating voltage as defined by the vehicle manufacturer.]

[It is allowed to vehicle manufacturer to calculate or simulate this value instead of measuring this after the crash.]

Measure and record the voltage (Vb) between the negative and the positive side of the high voltage bus (see figure 1):

Measure and record the voltage (V1) between the negative side of the high voltage bus and the electrical chassis (see figure 1):

Measure and record the voltage (V2) between the positive side of the high voltage bus and the electrical chassis (see figure 1):

If V1 is greater than or equal to V2, insert a standard known resistance (Ro) between the negative side of the high voltage bus and the electrical chassis. With Ro installed, measure the voltage (V1') between the negative side of the high voltage bus and the vehicle electrical chassis (see figure 3). Calculate the isolation resistance (Ri) according to the formula shown. Divide this electrical isolation resistance value (in Ω) by the working voltage of the high voltage bus (in volts).

$$R_i = R_o \cdot (V_b / V_1' - V_b / V_1) \quad \text{or} \quad R_i = R_o \cdot V_b \cdot (1 / V_1' - 1 / V_1)$$

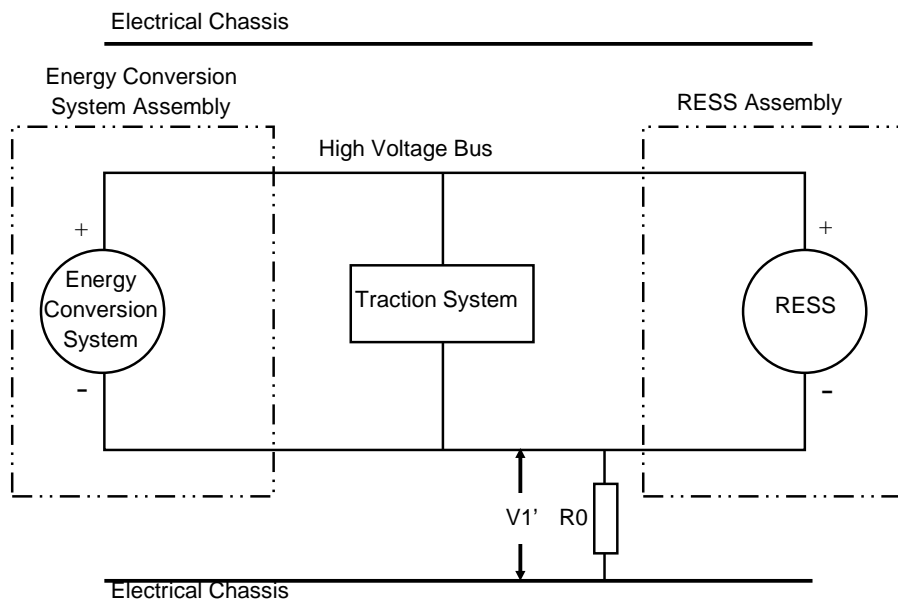

Figure 3: Measurement of V1'

If V_2 is greater than V_1 , insert a standard known resistance (R_0) between the positive side of the high voltage bus and the electrical chassis. With R_0 installed, measure the voltage (V_2') between the positive side of the high voltage bus and the electrical chassis (see figure 4).

Calculate the isolation resistance (R_i) according to the formula shown. Divide this electrical isolation value (in Ω) by the working voltage of the high voltage bus (in volts).

$$R_i = R_0 \cdot (V_b/V_2' - V_b/V_2) \quad \text{or} \quad R_i = R_0 \cdot V_b \cdot (1/V_2' - 1/V_2)$$

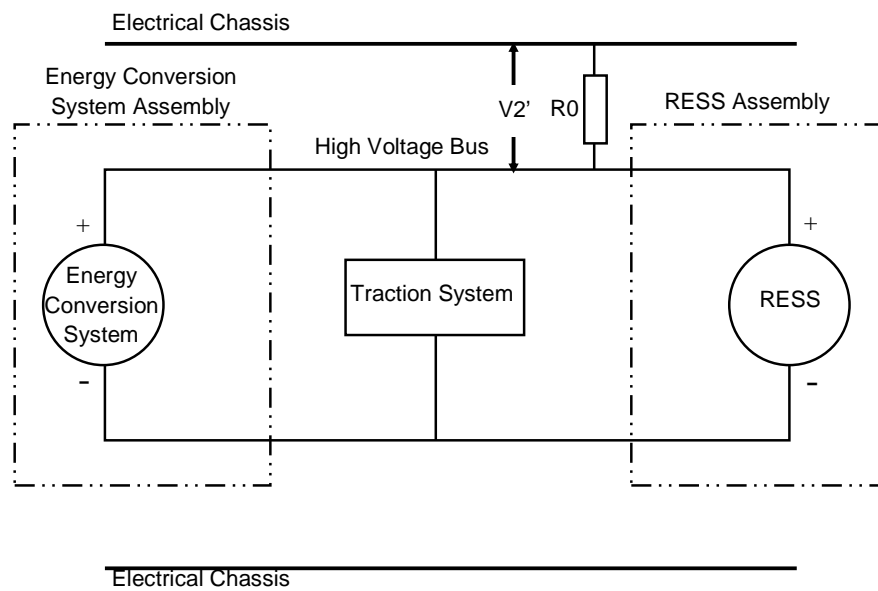

Figure 4: Measurement of V_2'

NOTE 1: The standard known resistance R_0 (in Ω) should be approximately 500 times the working voltage of the vehicle (in volts). R_0 is not required to be precisely this value since the equations are valid for any R_0 ; however, an R_0 value in this range should provide good resolution for the voltage measurements.

The isolation resistance between the high voltage bus and the electrical chassis may be demonstrated by calculation, measurement or a combination of both.

6. Electrolyte spillage

Appropriate paint shall be applied, if necessary, to the [original] physical protection in order to confirm the electrolyte is leaking from the RESS after the collision.

Add color to other liquid (such as coolant, oil, fuel, etc.), if necessary, so that the electrolyte and other liquid can be classified or separated.

If the electrolyte cannot be clearly identified from the other leaking liquids, all liquid shall be considered as the electrolyte.

7. RESS retention

Compliance shall be determined by visual inspection

Appendix 1

Protection against direct contacts of parts under voltage

1. Access probes

Access probes to verify the protection of persons against access to live parts are given in figure 1.

2. Test conditions

The access probe is pushed against any openings of the enclosure with the force specified in paragraph 4 of this annex. If it partly or fully penetrates, it is placed in every possible position, but in no case shall the stop face fully penetrate through the opening.

Internal barriers are considered part of the enclosure

A low-voltage supply (of not less than 40 V and not more than 50 V) in series with a suitable lamp should be connected, if necessary, between the probe and live parts inside the barrier or enclosure.

The signal-circuit method should also be applied to the moving live parts of high voltage equipment.

Internal moving parts may be operated slowly, where this is possible.

3. Acceptance conditions

The access probe shall not touch live parts.

If this requirement is verified by a signal circuit between the probe and live parts, the lamp shall not light.

In the case of the test for IPXXB, the jointed test finger may penetrate to its 80 mm length, but the stop face (diameter 50 mm x 20 mm) shall not pass through the opening. Starting from the straight position, both joints of the test finger shall be successively bent through an angle of up to 90 degree with respect to the axis of the adjoining section of the finger and shall be placed in every possible position.

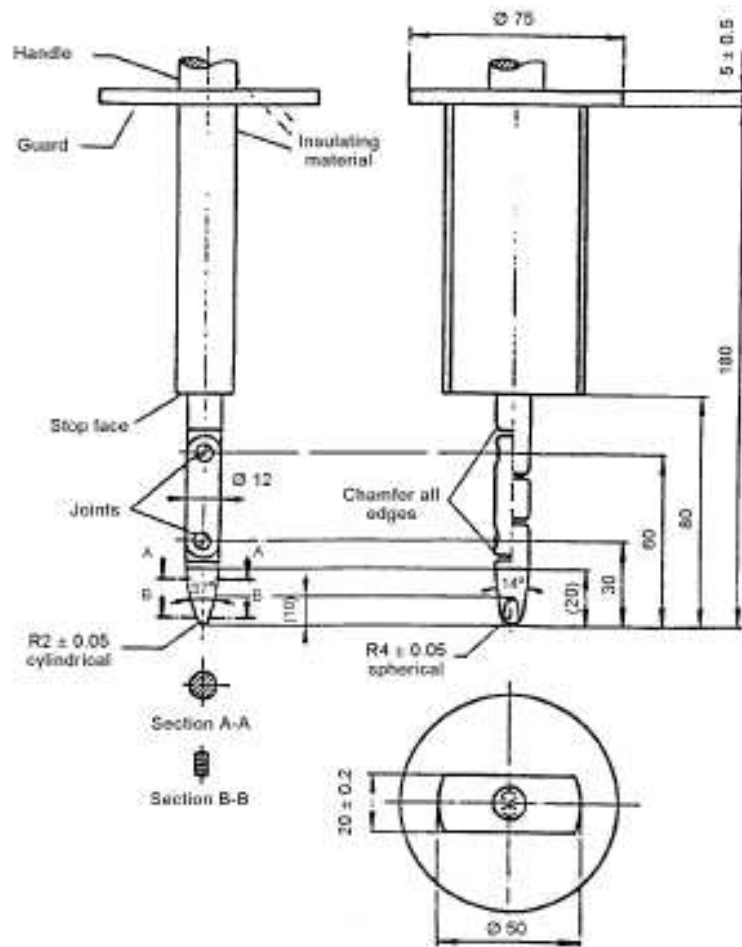

Figure 1: Jointed test finger

Material: metal, except where otherwise specified

Linear dimensions in millimeters

Tolerances on dimensions without specific tolerance:

- (a) on angles: 0/-10°
- (b) on linear dimensions: up to 25 mm: 0/-0.05 mm over 25 mm: ± 0.2 mm

Both joints shall permit movement in the same plane and the same direction through an angle of 90° with a 0 to +10° tolerance.”

II. Justification

This proposal incorporates provisions in order to ensure that M₁ vehicles, as defined in the scope of Regulation No. 94, with power train systems above a certain working voltage level, comply with general requirements on the electrical safety, for the protection of occupants after a crash test. The electrical safety requirements are based on amendments to Regulation No. 100, Informal document No. GRSP-46-04 distributed during the forty-sixth session of the Working Party on Passive Safety (GRSP) and results of the discussions at the EVPC informal group meeting held in Paris on 13-14 January 2010.

Contents, new Annex 11 and Appendix 1:

A new annex is inserted to cover electrical safety requirements according to the 01 series of amendments to Regulation No. 100.

Paragraph 2.6.7.:

The place of the electrical source(s) has been introduced in the vehicle type definition as a new parameter to take into account.

Paragraph 2.7.:

This amendment is necessary regarding the new prescriptions introduced for the passenger compartment for pure electrical safety aspects which is different from the original protection of occupants.

New paragraphs 2.15. to 2.33.:

New definitions used in the proposed amendments are inserted. They are in line with the current 01 series of amendments to Regulation No. 100 and /or modified specifically for the electrical safety requirements for crash tests.

New paragraph 3.2.6.:

“Application for approval” is modified to include information on the rechargeable energy storage system (RESS) type and the location of the electric power train.

Paragraph 5.2.:

The amended paragraph introduce paragraph 5.2.8. regarding electrical requirements to fulfil for the electric vehicle safety. It also introduces the possibility for the manufacturer to perform a separate crash test for the assessment of the EV electrical safety.

New paragraphs 5.2.8.1. to 5.2.8.3.:

These paragraphs deal with:

- (a) Electrical safety requirements;
- (b) Spillage requirements for RESS;
- (c) Cells and RESS locations and retention.

Control of electrical safety prescriptions is satisfied if at least one the four following requirements is met:

- (a) Absence of high voltage;
- (b) Energy on high voltage bus less than 0.2 j;
- (c) Physical barrier protection IPXXB and resistance between the electrical chassis and all exposed conductive parts shall be less than 0.1 ohm;

(d) Isolation resistance.

This proposal refers to the 01 series of amendments to Regulation No. 100 requirements considering separate or combined DC-AC buses to specify the minimum insulation resistance to achieve.

Modifications introduced reflect the state of discussions in the EVPC informal group.

Annex 1,

Communication,

New paragraph 5.3.:

This information is added in the communication certificate.

Annex 3,

Paragraph 1.4.1.:

This paragraph is devised to allow performing tests with the fuel system modified to have the engine running (e.g. with an additional small fuel tank) or the electrical energy conversion system running.

Paragraphs 1.4.2.2.:

This paragraph introduces provisions to take into account the case of vehicle equipped with hydrogen storage system to perform the test with alternative liquid instead of hydrogen for safety reasons as internal combustion engine vehicles.

New paragraphs 1.4.4. to 1.4.4.2.:

These paragraphs describe the test conditions of the electric power train.

Insert a new Annex 11:

This annex describes the test setup, measuring equipment and the different test procedure that can be used for validation of the different options mentioned in paragraph 5.2.8.3.

- (a) Bus voltage
- (b) Isolation resistance
- (c) Electrical energy
- (d) Physical Barrier

Isolation resistance measurement and physical barrier protection requirements are in line with the 01 series of amendments to Regulation No. 100. Accordingly, Appendix 1 introduces the measurement method for the protection against direct contacts of parts under voltage.