

Transmitted by the expert from Spain



Informal document No. **GRSG-95-31**  
(95th GRSG, 21 – 24 October 2008  
agenda item 3(e))

UN/ECE Regulation No. 107.01

TAAM Edinburgh October 2008

SPANISH COMMENTS ON QUESTION PL1

## **SUMMARY,**

### **ACCESSIBILITY OF EMERGENCY DOORS FOR MINIBUSES**

- 1.- Question PL1**
- 2.- Description of the problem**
- 3.- Previous situation**
- 4.- 1st approach: ECE Regulation No.52**
- 5.- 2nd approach: ECE R107.02**
- 6.- EC interpretation: Letter from Commission**
- 7.- TAAM interpretation Borlange 2005**
- 8.- CONCLUSSIONS**

This question was asked to TAAM members in a query sent out on the 18<sup>th</sup> of August 2008 with a response from 13 countries. The detailed summary is on pages 3 and 4 of this Question.

Since the overall result is inconclusive (7 - for, 6 - against), all TAAM members are kindly requested to prepare for a discussion in Edinburgh. This is addressed especially to the countries that have not replied to the query, i.e. Spain, Austria, Luxembourg, Finland, Estonia and Bulgaria.

With a kind permission of the Chairman, Poland would be pleased to deliver a short Power Point presentation prior to the discussion, as - in our opinion - the wording of both the Directive and the UN ECE Regulation concerning what is emergency door and what is emergency exit is not clear enough and confusing.

### **Background:**

The paragraph 7.6.1.1. of the directive 2001/85/EC (and of the UN ECE Regulation No. 107.02) says: “The minimum number of doors in a vehicle shall be two, either two service doors or one service door and one emergency door...”

### **Question:**

The drawing on the next page shows the vehicle in question. Would such a vehicle configuration obtain a type-approval certificate in your country in respect of the number of service and/or emergency doors?

Question PL1

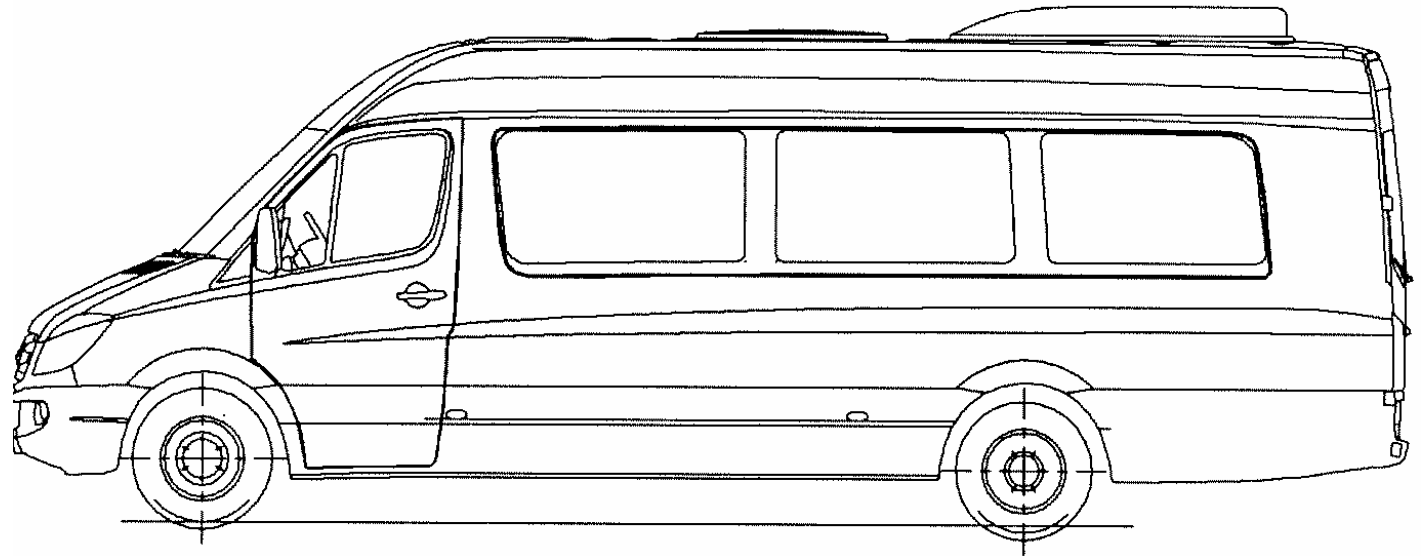
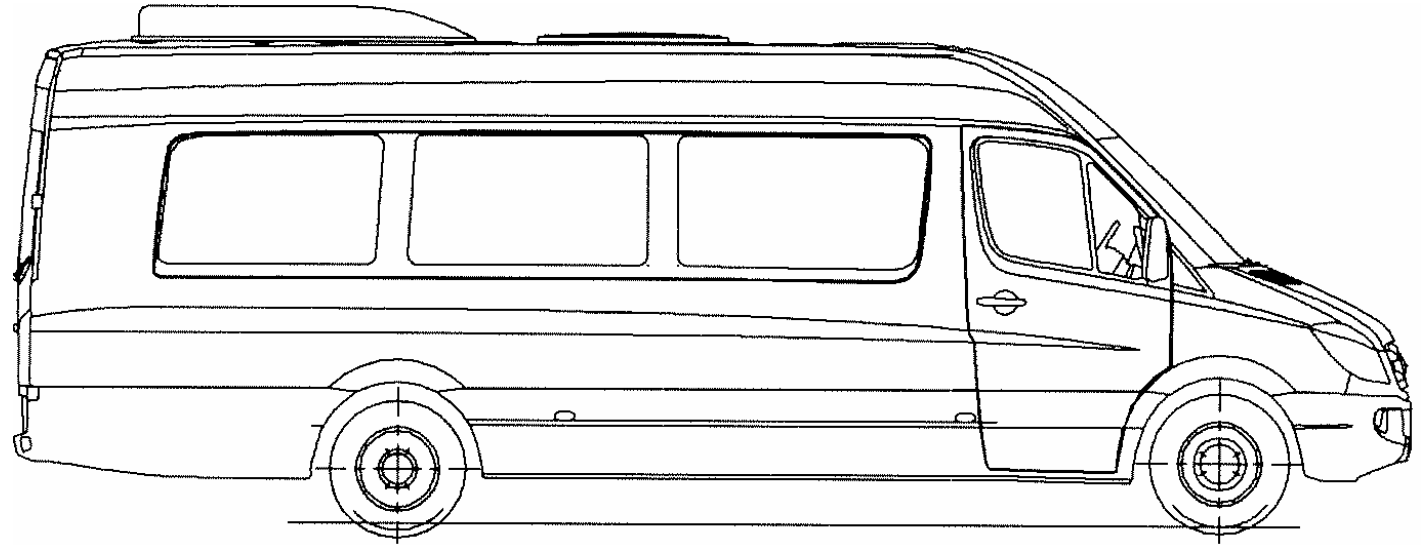

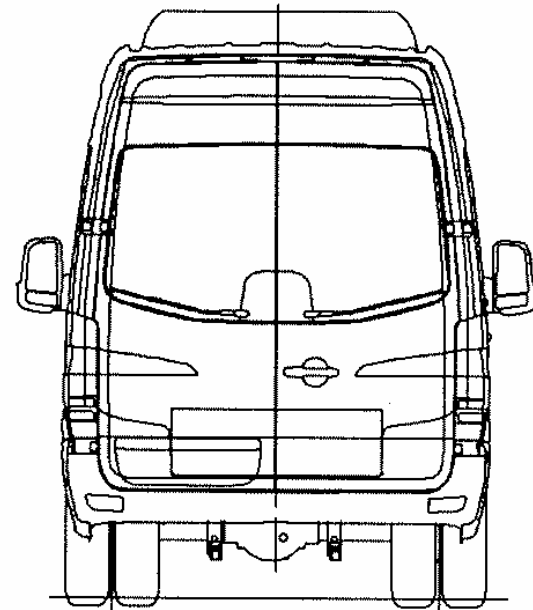
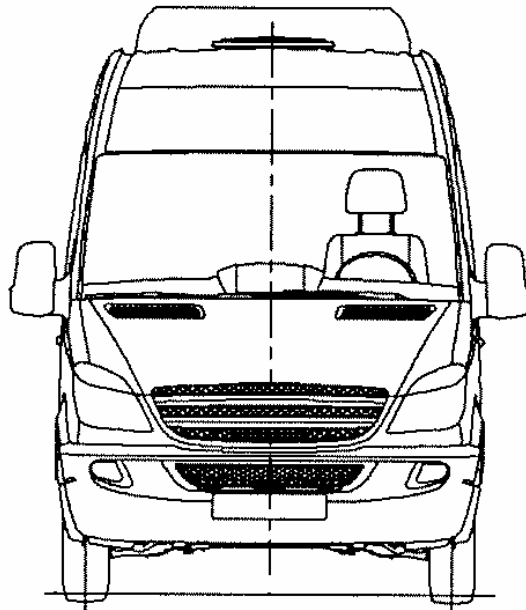
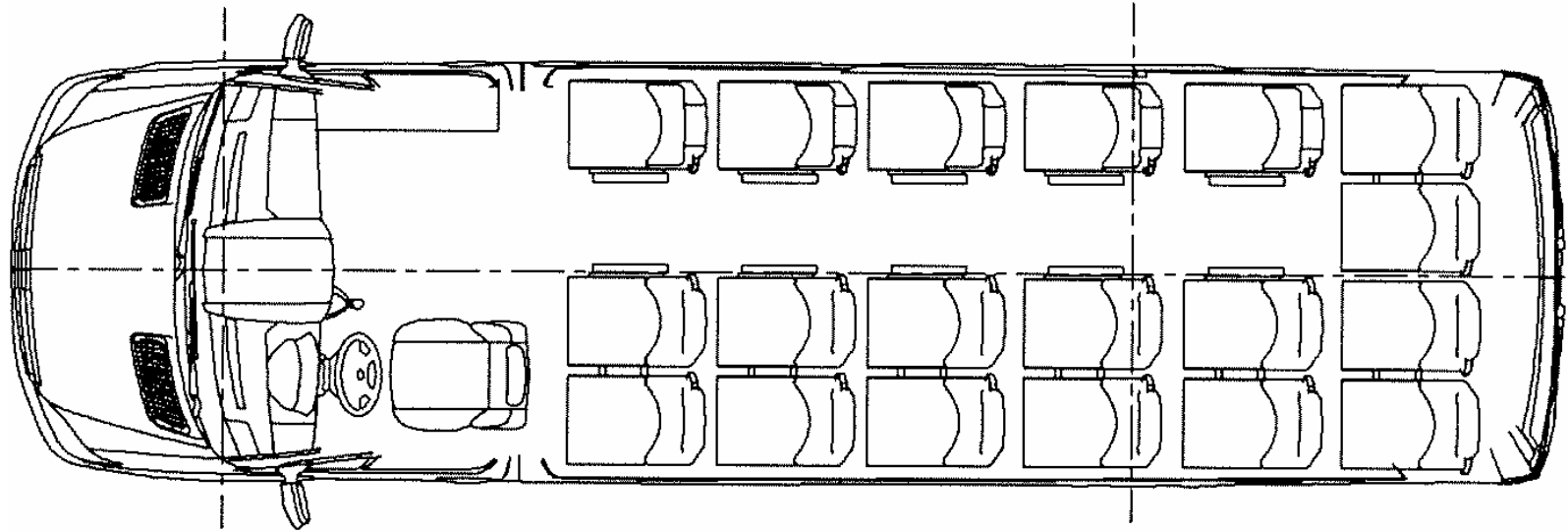

Question PL1

Previous situation: ECE Regulation No. 52.01 suppl 05

**Applicable until November 2004**

#### 5.6.2.5.2.

the driver's door shall be accepted as the emergency door for the occupants of the seats situated beside the driver's seat provided that the driver's seat, the steering wheel, the engine housing, the gear lever and handbrake control, etc., do not constitute too great an obstruction. 5/ The service door provided for the passengers shall be in the side of the vehicle opposite to that containing the driver's door and shall be accepted as the emergency door for the driver;

4/ In the country in which the vehicle is licensed for operation.

5/ An objective method of verifying that this requirement is satisfied may be established for the use of testing laboratories.

Foot note 5 originated a question from NL

After NL question,  
Modification of ECE R52.01 supl 07 to clarify the technical requirements:  
**Entry into force: November 2004**

#### 5.6.2.5.2

The driver's door shall be accepted as the emergency door for the occupants of the seats situated beside the driver's seat provided that it is possible to move a test gauge from the occupants' seats to the exterior of the vehicle through the driver's door (see annex 3, figure 21).

Verification of the access to the driver's door shall be subject to the requirements of paragraph 5.7.3.2., by using the test gauge having a dimension of 600x400 mm, as described in paragraph 5.7.3.3. The service door provided for the passengers shall be in the side of the vehicle opposite to that containing the driver's door and shall be accepted as the emergency door for the driver;"

See figures 21 and 22

Insert new figures 21 and 22, to read:

"Figure 21

ACCESS TO DRIVER'S DOOR

(See paragraph 5.6.2.5.2.)

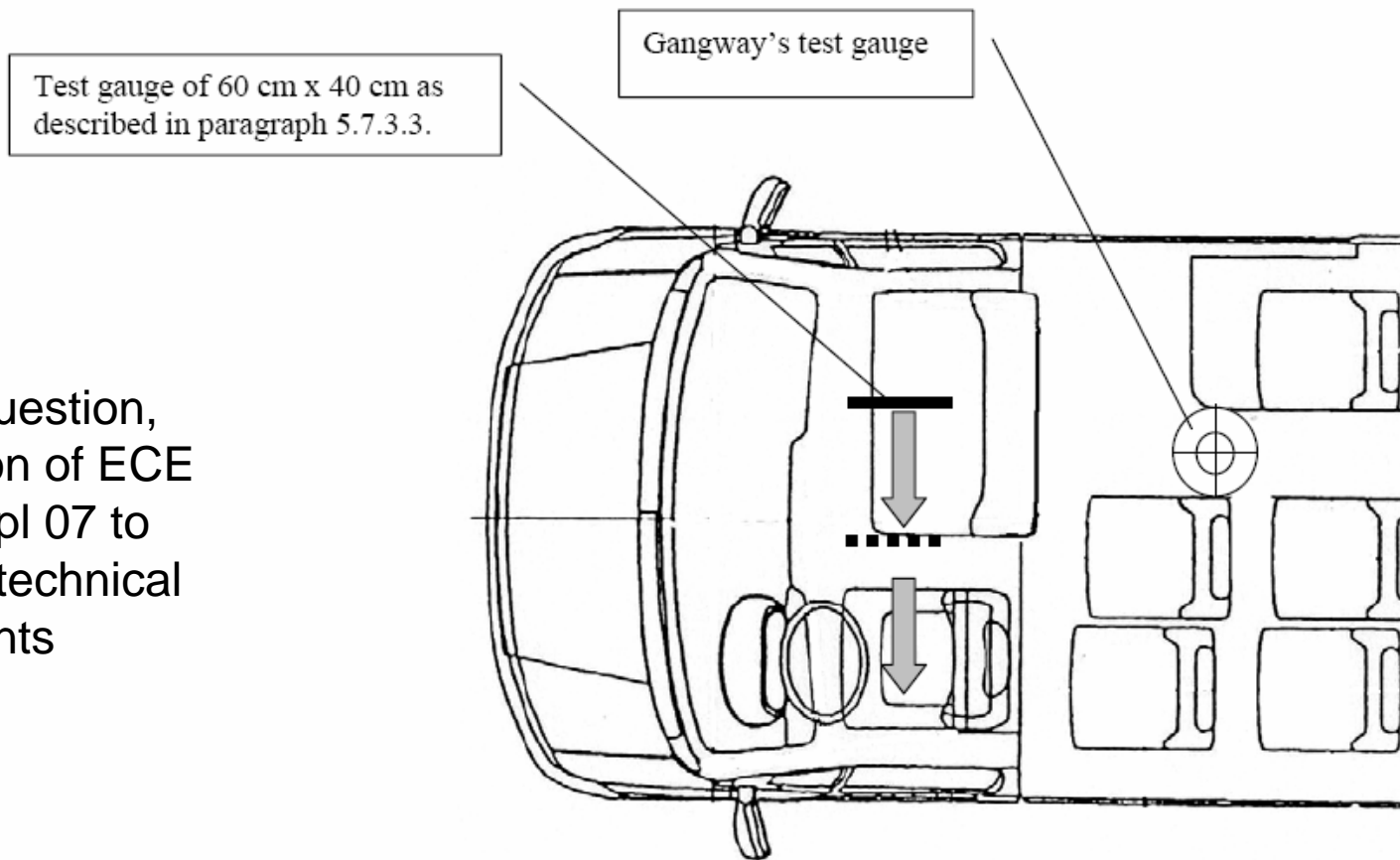

After NL question,  
Modification of ECE  
R52.01 supl 07 to  
clarify the technical  
requirements



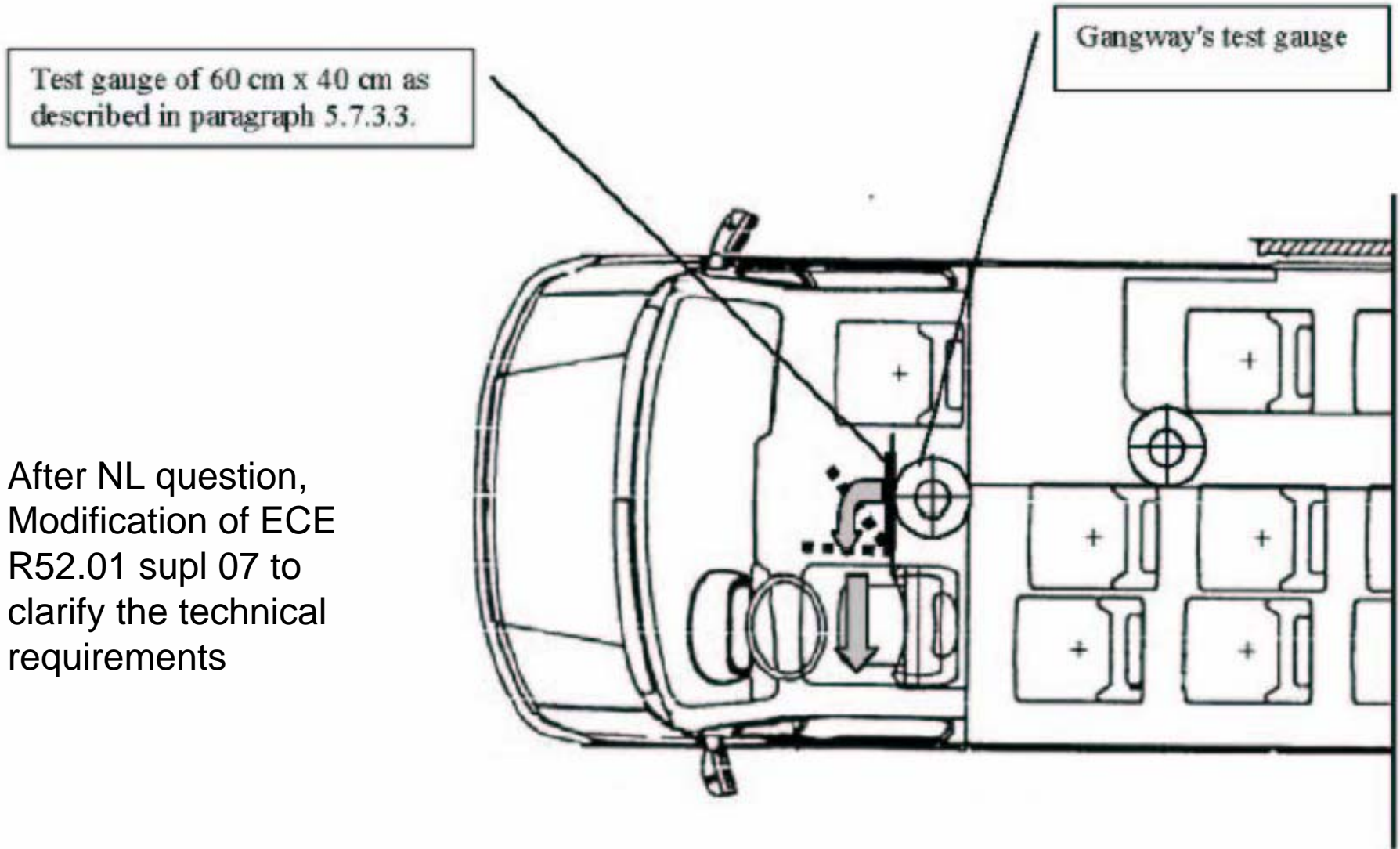

After NL question,  
Modification of ECE  
R52.01 supl 07 to  
clarify the technical  
requirements



**EUROPEAN COMMISSION**  
ENTERPRISE AND INDUSTRY DIRECTORATE-GENERAL

Consumer goods  
Automotive industry

Brussels, 31-05-2005  
ENTR/F/1 JPD/mv/D(2005) 15045

Mr Bo Lennartsson  
Lennartsson Trading AB  
Bodekullsvägen 38  
SE 702 33 Örebro  
Sweden

*Bosse@lennartsson.info*

**Subject: Driver's door as emergency exit in vehicles of Class B (minibuses)**

## EC Letter to TAAM

Recently, an amendment to UN/ECE Regulation 52<sup>1</sup> concerning certain construction aspects of small capacity vehicles (such as the *Strada* minibuses constructed by Idecar in Spain) has entered into force. Paragraph 5.7.2.4.2. of Regulation 52 as amended clarifies how to check the minimum free-space which must be provided between the steering wheel and the seat back in order to allow access to passengers, from the passenger compartment to the driver's door, so that the door can be regarded as an emergency exit.

Insofar as most of the technical provisions contained in Regulation 52 are similar to the corresponding provisions of Directive 2001/85/EC, the Commission services will consider the possible inclusion of this amendment within the Directive.

In the meantime, I will copy this letter to the members of the TAAM working party (Type-Approval Authorities Meeting) in order to avoid diverging interpretations of the Community legislation concerning this important safety provision.

Question/  
Subject

Issue

## TAAM 2005 BORLANGE

The issue is how to assess the minimum dimensions necessary to avoid squeezing between steering wheel and driver's seat in the case of an emergency.

Comment

The same problem has been encountered with the application of UN/ECE Regulation 52 for which an appropriate amendment has been adopted. The text of the amendment constitutes a significant improvement with respect to safety of occupants in a minibus; therefore, the Commission is proposing to include the same provisions in Directive 2001/85/EC.

In the meantime, the Commission recommends to TAAM experts to apply the provisions laid down in paragraph 5.7.2.4.2. of Regulation 52 when approving vehicle types in accordance with Directive 2001/85/EC. This solution has been already communicated to a company producing minibuses (See documents in annex).

[New Paragraph 5.7.2.4.2. in Reg 52

*Such requirement shall be deemed to be fulfilled if the test gauge described in paragraph 5.7.5.1. can move unobstructed from the gangway, until the front end of the gauge reaches the vertical plane tangential to the foremost point of the driver's seat back (this seat situated in its rearmost longitudinal position) and, from this plane, the panel described in paragraph 5.6.2.5.2. could be moved to the emergency door in the direction established by such paragraph (see annex 3, figure 22) with seat and steering wheel adjustment in their mid position.]*

## TYPE APPROVAL AUTHORITIES MEETING

27 and 28 SEPTEMBER 2005 – BORLÄNGE, SWEDEN

### MEETING MINUTES

Issue Date: 30 September 2005

*Decision*

The member states at the meeting support the Commissions' proposal to use the test gauge described in ECE R52 when verifying minimum dimension for accessibility.

Later on 2007, the ECE Regulation No.107 was amended accordingly:

**Addendum 106: Regulation No. 107**

**Revision 1 - Amendment 1**

02 series of amendments - Date of entry into force: 10 November 2007

**UNIFORM PROVISIONS CONCERNING THE APPROVAL OF CATEGORY M<sub>2</sub>  
OR M<sub>3</sub> VEHICLES WITH REGARD TO THEIR GENERAL CONSTRUCTION**

Insert a new paragraph 7.6.1.9.3., to read:

"7.6.1.9.3. the space reserved for the driver's seat shall communicate with the main passengers' compartment through an appropriate passage; such requirement shall be deemed to be fulfilled if the test gauge described in paragraph 7.7.5.1. can move unobstructed from the gangway, until the front end of the gauge reaches the

**Same paragraph and figures as in R52**

.../...

# Applus<sup>+</sup>

IDIADA

Conclusions,

Regarding TAAM question PL1, Spain considers that the matter was already considered by TAAM in Borlange 2005 meeting and the common agreement was

*“Agree to use the criteria of ECE R52.01 supl 07 (and latter 107.02) to verify the accessibility of the driver’s door to be considered as emergengy door as per 2001/85/EC directive.”*



**THANK YOU FOR YOUR ATENTION**

**Questions?**

**Comments?**